

Signal converter

Signal converter

Overview J.2 - J.5

DC/DC passive isolator

Input current loop-feed J.6 - J.7

Output current loop-feed J.8

Loop splitter J.9

DC/DC 2-way isolator

Power supply on the output side J.10

Double sided power supply J.11 - J.12

DC/DC 3-way isolator

10 Hz Cut-off frequency J.13 - J.15

20 kHz Cut-off frequency J.16 - J.19

Configurable J.20 - J.21

Supply isolator

Without / with HART J.22 - J.23

PT100 / RTD – Signal isolator / converter

PT100, Conductor converter J.24 - J.26

PT100, Conductor disconnecter converter J.27 - J.28

RTD Signal disconnecter converter J.29 - J.31

Thermo element Signal isolator / converter

Thermo disconnecter converter J.32 - J.35

Frequency Signal isolator / converter

DC/f disconnecter converter J.36 - J.37

f/DC disconnecter converter J.38 - J.39

Bridge measuring converter

Configurable J.40 - J.41

Interface converter

Serial interface converter

J.42 - J.43

AD-/DA-Converter

AD-Converter 8-bit J.44 - J.45

DA-Converter 8-bit J.46 - J.47

AD-Converter 12-bit J.48 - J.49

DA-Converter 12-bit J.50 - J.51

Logic modules

Preprocessing logic

J.52 - J.58

Monitoring modules

Current and voltage monitoring

Overview J.59

Relay output J.60

Analogue output J.61 - J.64

Voltage monitoring

Analogue output J.65

Threshold monitoring

Relay output / Transistor output J.66 - J.67

Accessories

Accessories

J.68 - J.70

Analogue Signal Processing

Analogue signal processing

Problems

The real environment can be measured in many different forms, for example in terms of temperature, humidity or air pressure. The values of these physical variables change constantly. Elements which monitor the statuses and status changes of a given environment and supply an indication of this changed environment must be able to portray the continuous change.

In industrial monitoring tasks, sensors are responsible for registering ambient statuses. Sensors provide signals which allow detailed conclusions for downstream evaluation and monitoring systems with detailed conclusions about the statuses or status changes, for example in a production process. Sensor signals monitor continuous changes in the monitored field. They occur in digital and analogue form. As a rule, they supply an electrical voltage or current value which corresponds proportionally to the physical variables being monitored.

If automation processes are expected to reach certain statuses or keep them constant, then analogue signal processing is required. It is also important in areas where this has already been part of long established practice, for example process engineering or the chemicals industry.

In process engineering, standardised electrical signals are normally used. Currents from 0... 20 mA, 4... 20 mA or voltages from 0..10 V have become established as the output variable for sensors of various different physical parameters.

Weidmüller takes account of the continuing trend to automate – including and in particular with analogue signal processing – and offers a wide range of products tailor-made to the requirements involved in handling sensor signals. Units for the common signals (0..20 mA, 4..20 mA, 0..10 V) generate an output signal as proportional values of the variable input signal. “Protective separation” e.g. of the sensor circuit from the evaluation circuit is also taken into account. “Protective separation” prevents mutual interference of several sensor circuits, for example as in the case of earth ground circuits in linked measuring circuits.

The wide range of products completely covers the functions involved in signal conversion, signal separation and signal monitoring. The products thus satisfy nearly all applications in industrial measuring technology, and safeguard elementary functions between field signals and further processing systems. The mechanical properties of the products are built up around a continuous concept.

Signal converters can be used with other Weidmüller products and combined with each other. They are designed from an electrical and mechanical point of view so as to entail a minimum wiring workload and maintenance.

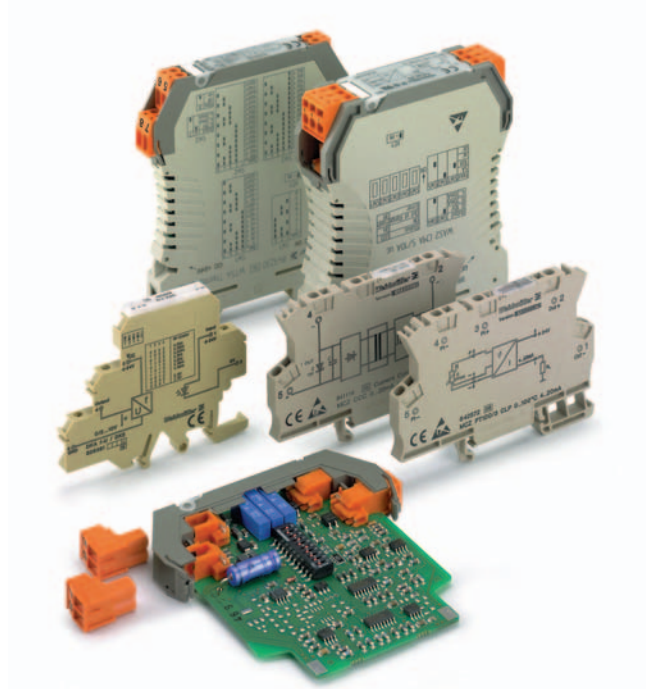

The product programme contains the following functions:

- dc/dc converters
- Current converters
- Voltage converters
- Temperature transformers for resistance thermometers and thermoelements
- Frequency converters
- Potentiometer transducers
- ac transducers
- Bridge transducers (strain gauges)
- Threshold monitoring modules
- AD/DA converters

The stated products are available as pure signal conversion, 2-way isolation, 3-way isolation and passive disconnectors – depending on the production functions in each case.

Analogue Signal Processing

Weidmüller interface units

2-way isolation separates the signals and decouples the measuring circuits. Potential differences, caused by long line leads and joint reference points, are eliminated. Signal isolation also protects from destruction by overvoltage together with inductive and capacitive gaps.

3-way isolation also separates the supply voltage to the input and output circuit and allows for operation with only one operating voltage.

Passive isolators have another crucial advantage: they do not need any additional power supply. The power supply for the module comes from the input or output circuit and is transferred to the input/output. The outstanding feature of this current loop feed is its very low own consumption.

There is a wide range of products for measuring temperature. **PT100** signals are converted in 2, 3 and 4-conductor system to standardised signals 0-20 mA, 4-20 mA and 0-10 V.

The modules for connecting to commercially available **thermocouples** have cold joint compensation as a standard feature. In addition, they amplify and linearise the voltage signal issued by the thermocouple. This guarantees exact conditioning of the analogue signal, eliminating interference or fault sources.

Frequency converters convert frequency into analogue standard signals so that subsequent controllers can directly process pulse sequences for speed or velocity measurement.

No kind of automation is conceivable without **AD or DA converters**. To bring together the analogue signals which portray the environment with the digital processing of the process monitoring system, analogue signals have to be converted into digital ones. Weidmüller also offers these modules for the common input and output signals 0 ... 20 mA, 4 ... 20 mA and 0 ... 10 V, with 8 bit or 12 bit available on the digital side. All modules have an additional input for freezing the current measured value.

Current monitoring modules control the current values up to 60 A for dc or ac current. If the values fall below or above the setting, then the switch output is triggered. Modules with analogue outputs monitor the current flow continuously using subsequent controllers.

Voltage monitoring modules are used to monitor dc and ac voltage. The freely adjustable switching threshold can be used to detect and report fluctuations in voltage as a result of switching procedures or mains overload.

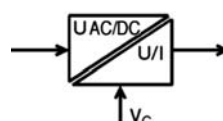
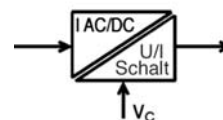
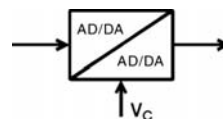
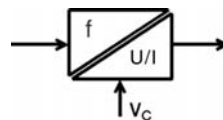
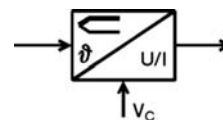
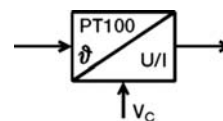
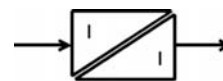
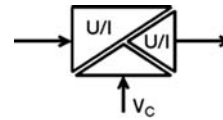
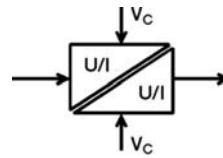

Advantages of the WAVESERIES

The concept

The modules in the WAVESERIES are ideal when users need analogue separating transducers. Weidmüller's WAVESERIES combines the compact, space-saving design of the enclosure type (WAVEBOX) with many different functions. The product family offers a wide range of signal transducers.

- Independent connection technology – screw or spring with pluggable socket connector
- Assembly without tools
- Fast commissioning – pluggable spare boards
- Standardised current and voltage signals
- Cross connectors for low wiring workload
- Highly functional
- Clear type designations for simple selection
- Ideal size – for more space in the switchgear cabinet
- Cost-saving

Replacement

The PCB can be removed from the enclosure without any tools. Simple press in the locking hook at the top section and pull out the upper part with connection level and PCB.

Cross connection

Cross connectors are used to connect up enclosures in the same family to bridge and transmit the power supply from one module to the next.

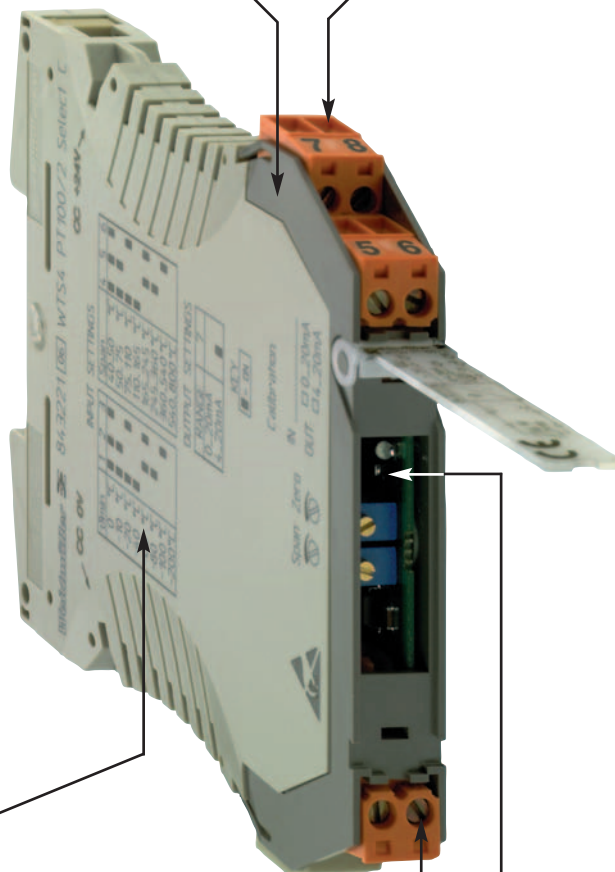
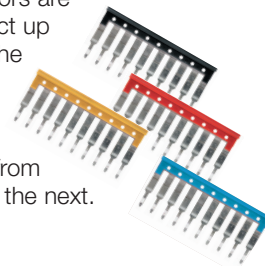

Enclosure (WAVEBOX)

The WAVEBOX is an ideal combination of technology, design and functionality. The enclosure consists of recyclable plastic and comes in four different widths. It needs practically no tools for assembly and fulfils the EMC requirements. Ventilation slots allow good heat dissipation.

Coding

The coding elements can be used to code the module for screw and also tension clamp connections without loss of poles. In this way, it is not possible to confuse the plugs.

Connecting

Screw connection BLZ and the tension clamp system BLZF offer the greatest possible flexibility in the wiring stage (up to 2.5 mm²).

Safety

"Protective separation" has to be guaranteed as per EN 50178. WAVESERIES complies with this requirement to the full with analogue signal transmission with potential separation.

Advantages of the MICROSERIES and MCZ SERIES

Connecting

Screw connection BLZ and the tension clamp system BLZF offer the greatest possible flexibility in the wiring stage (up to 2.5 mm²).

Cross connection

The supply voltage can be bridged from one module to the next.

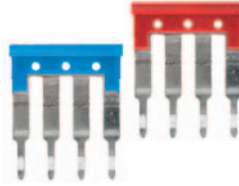

Width

MICROANALOGUE sets standards for analogue signal processing. With a width of just 6 mm, MICROSERIES is highly functional with a completely closed enclosure.

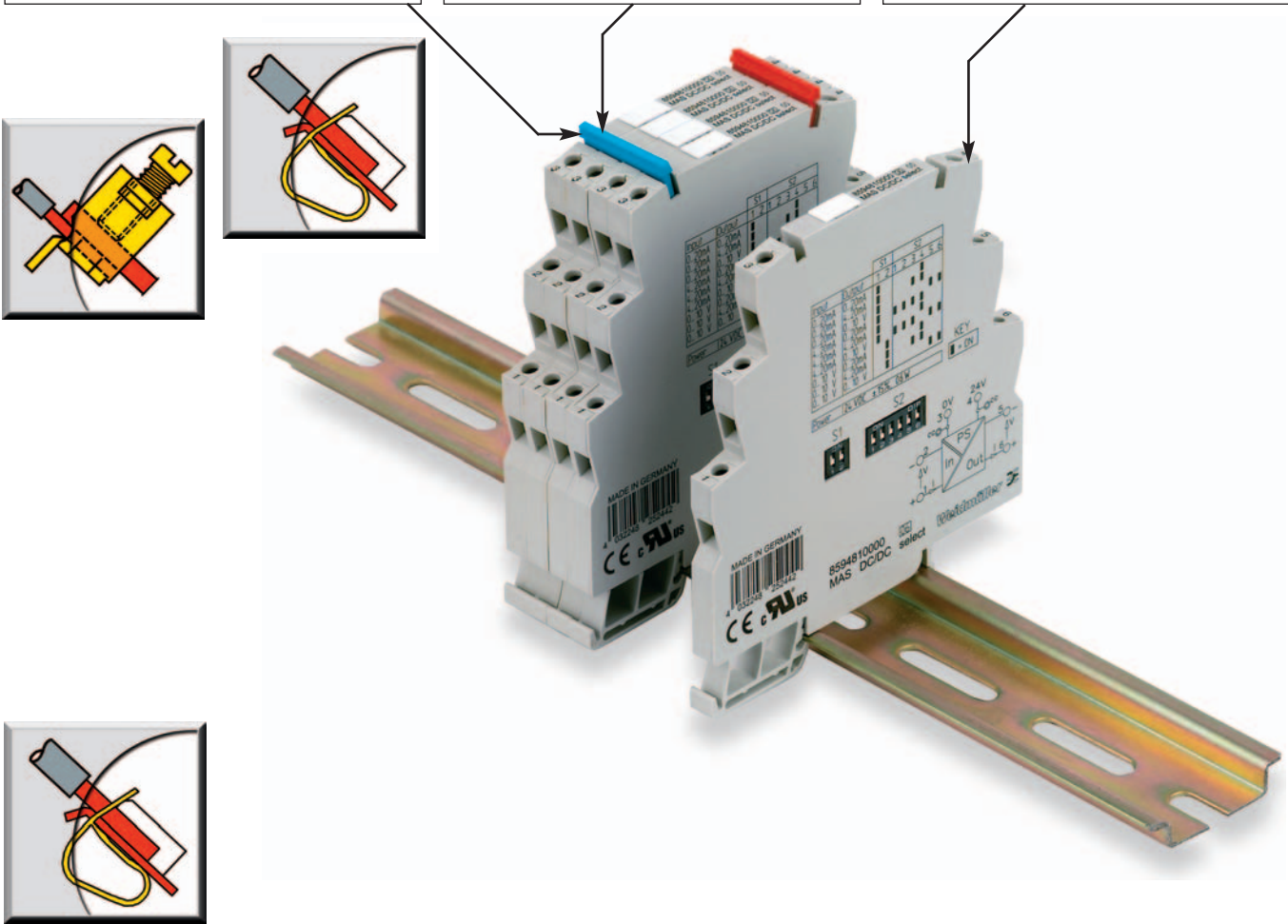

Connecting

Tension spring connection

Cross connection

The power supply and another potential can be cross connected

Width

Just 6 mm wide (without cover plate), the MCZ SERIES offers enough space for electronic circuits.

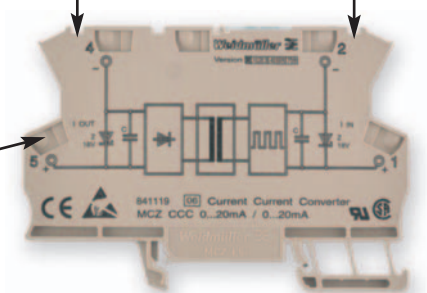

DC/DC passive isolator

Input current loop-fed

Passive isolator for electrical isolation of standard 0/4...20 mA signals. It is fed by the measuring signal and does not need any auxiliary power supply. Special features of this component are its low power consumption and the operating current of <math>< 100 \mu\text{A}</math>.

MCZ CCC

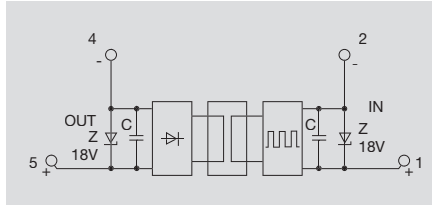
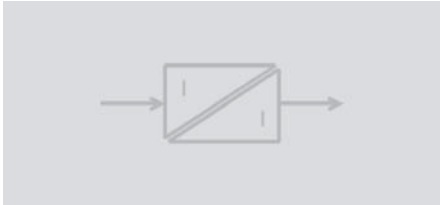
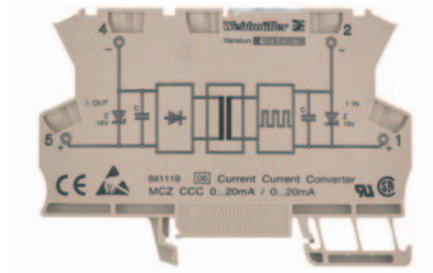

Technical data

Input

Input voltage/Input current
Max. voltage/Max. current
Operating current
Voltage drop

/0(4)...20 mA current loop
15 V/50 mA
<math>< 100 \mu\text{A}</math>
2.5...3 V at 20 mA

Output

Output voltage/Output current
Load resistance voltage/Current
Accuracy
Temperature coefficient
Influence of load impedance
Residual ripple
Chopper frequency

/0(4)...20 mA
<math>/< = 500 \Omega</math>
<math>< 0.1 \text{ \%}</math> of final value
<math>< 50 \text{ ppm/K}</math> of measurement value at 0 Ω load resist.
0.05 % of measurement value/100 Ω load resistance
<math>< 10 \text{ mVeff}</math>
Approx. 200 kHz

General data

Operation temperature
Storage temperature
Approvals

-25 °C...+60 °C
-40 °C...+85 °C
CSA / UL/UR / CE / ESD

Insulation coordinates

Standards
EMC standards
Isolation voltage Input, output

EN 60529, EN 61010-1
EN 50081-1, EN 50082-2
510 Veff

Dimensions

Clamping range (rating- / min. / max.) mm²
Length x width x height mm

Tension clamp c.

1.50 / 0.50 / 1.50
91.0 x 6.0 x 63.2

Information

Ordering data

Type of connection

Tension clamp c.

Type	Qty.	Order No.
MCZ CCC 0-20mA/0-20mA	10	8411190000

Information

Accessories

Information

DC/DC passive isolator

Input current loop-fed

- Galvanic isolation
- Very low power consumption
- Secure disconnection

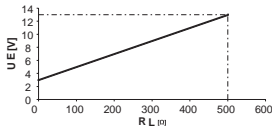

CCC LP

(1-channel)

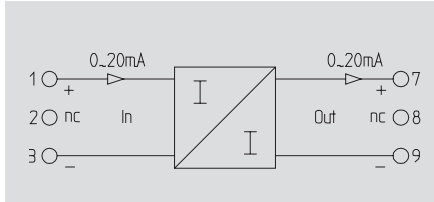

CCC LP

(2-channel)

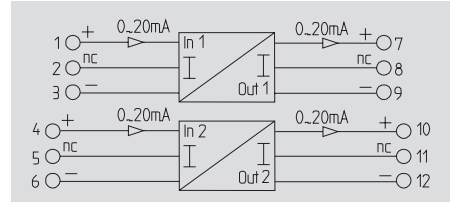

Technical data

Input

Input voltage/Input current
Max. voltage/Max. current
Operating current
Voltage drop

Output

Output voltage/Output current
Load resistance voltage/Current
Accuracy
Temperature coefficient
Influence of load impedance
Residual ripple
Chopper frequency

General data

Operation temperature
Storage temperature
Approvals

Insulation coordinates

Standards
EMC standards
Rated voltage
Impulse withstand voltage
Isolation voltage Input, output
Overvoltage category
Pollution severity
Clearance & creepage path

/0(4)...20 mA current loop

18 V/50 mA

< 100 µA

approx. 3V at RL=0 Ω; approx. 13V at RL=500 Ω;(lin=20mA)

/0(4)...20 mA

/< = 500 Ω

< 0.1 % of final value

< 50 ppm/K of final value

< 0.1 % of measurement value/100 Ω load resistance

< 20 mVeff

approx. 170 kHz

-25 °C...+70 °C

-40 °C...+80 °C

CSA / GL / UL/UR / CE / ESD

EN 50178 (safe separation)

EN 50081, EN50082, EN55011

300 V

6 kV

4 kVeff / 1 s

III

2

>= 5.5 mm

/0(4)...20 mA current loop

18 V/50 mA

< 100 µA

approx. 3V at RL=0 Ω; approx. 13V at RL=500 Ω;(lin=20mA)

/0(4)...20 mA

/< = 500 Ω

< 0.1 % of final value

< 50 ppm/K of final value

< 0.1 % of measurement value/100 Ω load resistance

< 20 mVeff

approx. 170 kHz

-25 °C...+70 °C

-40 °C...+80 °C

CSA / GL / UL/UR / CE / ESD

EN 50178 (safe separation)

EN 50081, EN50082, EN55011

300 V

6 kV

4 kVeff / 1 s

III

2

>= 5.5 mm

Dimensions

Clamping range (rating- / min. / max.) mm²
Length x width x height mm

Information

Screw connection

2.50 / 0.50 / 2.50

92.4 x 17.5 x 112.4

Tu=23°C, single module

Tension clamp c.

1.50 / 0.50 / 2.50

92.4 x 17.5 x 112.4

Screw connection

2.50 / 0.50 / 2.50

92.4 x 17.5 x 112.4

Tu=23°C, single module

Tension clamp c.

1.50 / 0.50 / 2.50

92.4 x 17.5 x 112.4

Ordering data

Type of connection

Screw connection
Tension clamp c.

Type

WAS5 CCC LP 0-20/0-20mA

WAZ5 CCC LP 0-20/0-20mA

Qty.

1

1

Order No.

8444950000

8444960000

Type

WAS5 CCC LP 0-20/0-20mA

WAZ5 CCC LP 0-20/0-20mA

Qty.

1

1

Order No.

8463580000

8463590000

Information

Accessories

Information

Articles with coloured order number are kept permanently in stock at the central warehouse in Germany.
Delivery times see page X.2

DC/DC passive isolator

Output current loop-fed

- Galvanic isolation
- Very low power consumption
- Input range selected via DIP switch
- Calibration not necessary

OLP

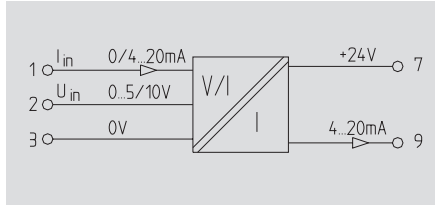
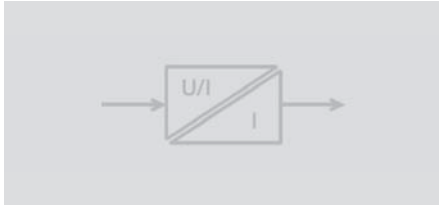

Switch position/setting options

Input	SW 1			
	1	2	3	4
0...20 mA	<input type="checkbox"/>	<input type="checkbox"/>	<input type="checkbox"/>	<input type="checkbox"/>
4...20 mA	<input checked="" type="checkbox"/>	<input type="checkbox"/>	<input type="checkbox"/>	<input type="checkbox"/>
0...5 V	<input checked="" type="checkbox"/>	<input checked="" type="checkbox"/>	<input checked="" type="checkbox"/>	<input type="checkbox"/>
0...10 V	<input type="checkbox"/>	<input checked="" type="checkbox"/>	<input type="checkbox"/>	<input type="checkbox"/>
Transmission frequency				
10 Hz	<input type="checkbox"/>	<input type="checkbox"/>	<input type="checkbox"/>	<input checked="" type="checkbox"/>
100 Hz	<input type="checkbox"/>	<input type="checkbox"/>	<input type="checkbox"/>	<input type="checkbox"/>

■ = on
□ = off

Technical data

Input

Input voltage
Max. voltage
Input resistance voltage/Current
Input current
Max. current

0... (5)10 V
30 Vdc
0...5V: 210 k Ω ; 0...10V: 430 k Ω /51 Ω
0(4)...20 mA
40 mA

Output

Output current
Output signal limit
Load resistance voltage/Current
Accuracy
Temperature coefficient
Residual ripple
Step response time
Cut-off freq. (-3dB)

4...20 mA (current loop)
approx. 24 mA
/RL=(Ub-12V) / 20 mA e.g. 600 Ω at 24V
0.2 % of measuring range final value
 \leq 150 ppm/K
50 mVeff at 500 Ω
 $<$ 10 Hz: 80 ms; 100 Hz: 50 ms
10 Hz/ 100 Hz switchable

General data

Supply voltage
Operation temperature
Storage temperature
Default settings
Approvals

min. 12 Vdc/ max. 30 Vdc
0 $^{\circ}$ C...+55 $^{\circ}$ C (fitted)
-20 $^{\circ}$ C...+85 $^{\circ}$ C
0...20mA, 10 Hz
CE / ESD / cURus

Insulation coordinates

Standards
EMC standards
Rated voltage
Impulse withstand voltage
Isolation voltage Input, output
Overvoltage category
Pollution severity
Clearance & creepage path

EN 50178
EN 50082-2, EN 50081-1, -2, EN 55011
300 V
4 kV
4 kVeff / 5s
III
2
 \geq 5.5 mm

Dimensions

Clamping range (rating- / min. / max.) mm²
Length x width x height mm

Screw connection

2.50 / 0.50 / 2.50
92.4 x 17.5 x 112.4

Tension clamp c.

1.50 / 0.50 / 2.50
92.4 x 17.5 x 112.4

Information

Tu=23 $^{\circ}$ C, single module

Ordering data

Type of connection

Screw connection
Tension clamp c.

Type	Qty.	Order No.
WAS5 OLP	1	8543720000
WAZ5 OLP	1	8543730000

Information

Accessories

Information

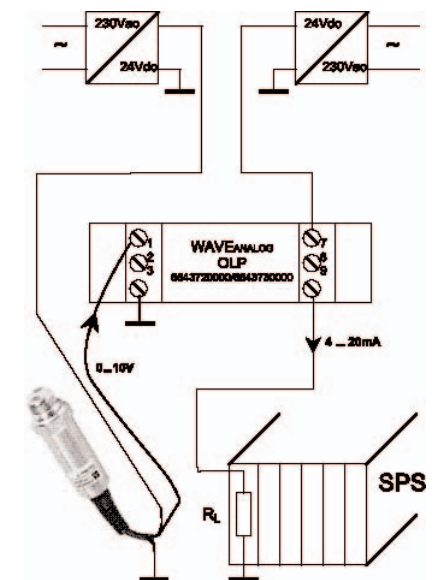

DC/DC passive isolator

Loop splitter

- Galvanic isolation
- Input and output current loop feed
- Very low power consumption
- Calibration not necessary

20LP

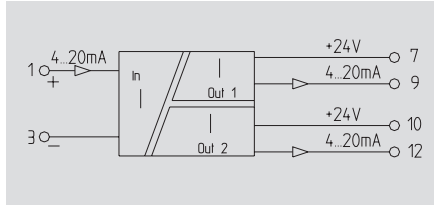
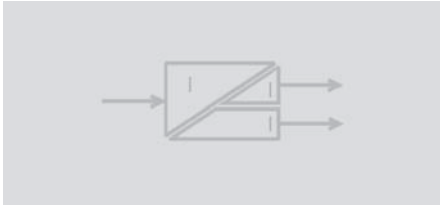

Technical data

Input

Input current
Max. current
Voltage drop

4...20 mA (current loop)
40 mA
3.8 V

Output

Output current/
Output signal limit
Load resistance voltage/Current
Accuracy
Temperature coefficient
Step response time
Cut-off freq. (-3dB)

2 x 4...20 mA (current loop)/
approx. 31 mA
 $R_L = (U_b - 12V) / 20 \text{ mA}$ e.g. 600Ω at 24V
typical 0.1%, max. 0.2%
 $\leq 150 \text{ ppm/K}$
 $< 20 \text{ ms}$
30 Hz

General data

Supply voltage
Operation temperature
Storage temperature
Approvals

min. 12 Vdc/ max. 30 Vdc
 $0^\circ\text{C} \dots +55^\circ\text{C}$ (fitted)
 $-20^\circ\text{C} \dots +85^\circ\text{C}$
CE / ESD / cURus

Insulation coordinates

Standards
EMC standards
Rated voltage
Impulse withstand voltage
Isolation voltage Input, output/
Overvoltage category
Pollution severity
Clearance & creepage path

EN 50178
EN 50082-2, EN 50081-1, -2, EN 55011
300 V
4 kV
4 kVeff / 5s/
III
2
 $\geq 5.5 \text{ mm}$

Dimensions

Clamping range (rating- / min. / max.) mm²
Length x width x height mm

Screw connection

2.50 / 0.50 / 2.50
92.4 x 17.5 x 112.4

Tension clamp c.

1.50 / 0.50 / 2.50
92.4 x 17.5 x 112.4

Information

Tu=23°C, single module

Ordering data

Type of connection

Screw connection
Tension clamp c.

Type

Type	Qty.	Order No.
WAS5 CCC 20LP	1	8581160000
WAZ5 CCC 20LP	1	8581170000

Information

Accessories

Information

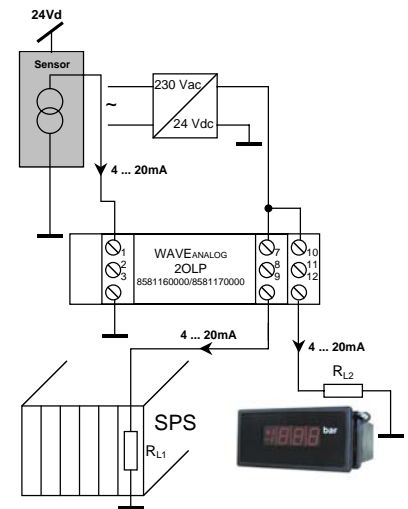

DC/DC 2-way isolator

Power supply on the output side

- Signal conversion
- Galvanic isolation between input/output signal
- Power supply can be cross-connected via plug-in jumpers

4...20mA/4...20mA



4...20mA/0...20mA



4...20mA/0...10V

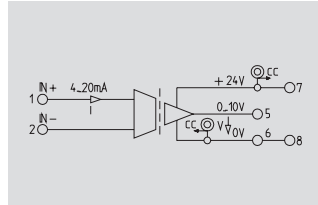
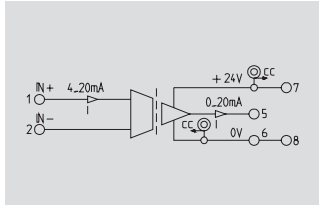
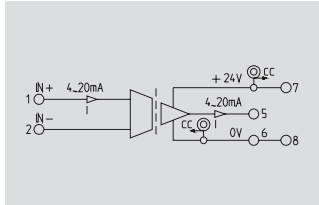
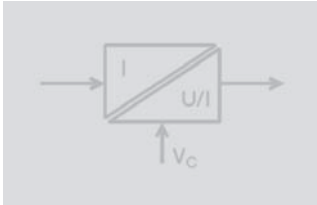

Technical data

Input

Input voltage/Input current
Max. voltage
Max. current

Output

Output voltage/Output current
Load resistance voltage/Current
Accuracy
Temperature coefficient
Step response time
Cut-off freq. (-3dB)

General data

Supply voltage
Current consumption
Current-carrying cap. of cross-connect.
Operation temperature
Storage temperature
Approvals

Insulation coordinates

Standards
EMC standards
Rated voltage
Impulse withstand voltage
Isolation voltage Input, output/
Overvoltage category
Pollution severity
Clearance & creepage path

/4...20 mA (current loop)
7 V
25 mA

/4...20 mA
<math><= 500 \Omega</math>
+/- 0.2% of final value
<math><= 250 \text{ ppm/K}</math> of final value
<math><= 30 \text{ ms}</math> (typically 20 ms)
>math>>= 15 \text{ Hz}</math> (typically 20 Hz)

24 Vdc +/- 20 %
<math>< 32 \text{ mA}</math> at Iout = 20 mA
<math><= 2 \text{ A}</math>
0 °C...+55 °C (fitted)
-20 °C...+85 °C
CSA / UL/UR / CE / ESD

EN 50178
EN 50081, EN50082, EN55011

300 V
4 kV

1.2 kVeff / 5s/
III
2
>math>>= 3 \text{ mm}</math>

/4...20 mA (current loop)
7 V
25 mA

/0...20 mA
<math><= 500 \Omega</math>
+/- 0.2% of final value
<math><= 250 \text{ ppm/K}</math> of final value
<math><= 30 \text{ ms}</math> (typically 20 ms)
>math>>= 15 \text{ Hz}</math> (typically 20 Hz)

24 Vdc +/- 20 %
<math>< 32 \text{ mA}</math> at Iout = 20 mA
<math><= 2 \text{ A}</math>
0 °C...+55 °C (fitted)
-20 °C...+85 °C
CSA / UL/UR / CE / ESD

EN 50178
EN 50081, EN50082, EN55011

300 V
4 kV

1.2 kVeff / 5s/
III
2
>math>>= 3 \text{ mm}</math>

/4...20 mA (current loop)
7 V
25 mA

0...10 V/
>math>>= 1 \text{ k}\Omega</math>
+/- 0.2% of final value
<math><= 250 \text{ ppm/K}</math> of final value
<math><= 30 \text{ ms}</math> (typically 20 ms)
>math>>= 15 \text{ Hz}</math> (typically 20 Hz)

24 Vdc +/- 20 %
<math>< 20 \text{ mA}</math> at Iout = 10 mA
<math><= 2 \text{ A}</math>
0 °C...+55 °C (fitted)
-20 °C...+85 °C
CSA / UL/UR / CE / ESD

EN 50178
EN 50081, EN50082, EN55011

300 V
4 kV

1.2 kVeff / 5s/
III
2
>math>>= 3 \text{ mm}</math>

Dimensions

Clamping range (rating- / min. / max.) mm²
Length x width x height mm

Information

Screw connection Tension clamp c.

2.50 / 0.50 / 2.50 1.50 / 0.50 / 2.50
92.4 x 12.5 x 112.4 92.4 x 12.5 x 112.4

Tu=23°C, single module

Screw connection Tension clamp c.

2.50 / 0.50 / 2.50 1.50 / 0.50 / 2.50
92.4 x 12.5 x 112.4 92.4 x 12.5 x 112.4

Tu=23°C, single module

Screw connection Tension clamp c.

2.50 / 0.50 / 2.50 1.50 / 0.50 / 2.50
92.4 x 12.5 x 112.4 92.4 x 12.5 x 112.4

Tu=23°C, single module

Ordering data

Type of connection

Screw connection
Tension clamp c.

Type	(Qty.=1)	Order No.
WAS4 CCC DC 4-20/4-20MA		8444980000
WAZ4 CCC DC 4-20/4-20MA		8444990000

Type	(Qty.=1)	Order No.
WAS4 CCC DC 4-20/0-20MA		8445010000
WAZ4 CCC DC 4-20/0-20MA		8445020000

Type	(Qty.=1)	Order No.
WAS4 CVC DC 4-20/0-10V		8445040000
WAZ4 CVC DC 4-20/0-10V		8445050000

Information

Accessories

Information

Voltage supply 24V and 0V with ZQV 2.5N/2 cross-connection

Voltage supply 24V and 0V with ZQV 2.5N/2 cross-connection

Voltage supply 24V and 0V with ZQV 2.5N/2 cross-connection

DC/DC 2-way isolator

Double sided power supply

- Signal conversion
- Galvanic isolation between input/output signal
- Power supply can be cross-connected via plug-in jumpers

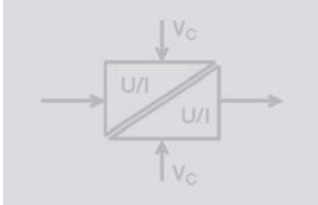

0...20mA/0...20mA

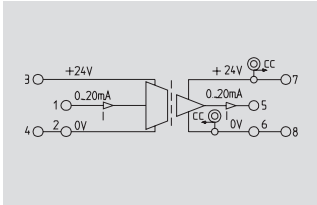

0...20mA/4...20mA

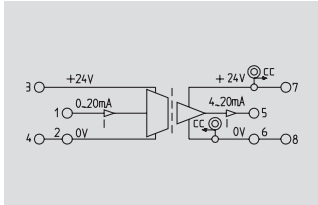
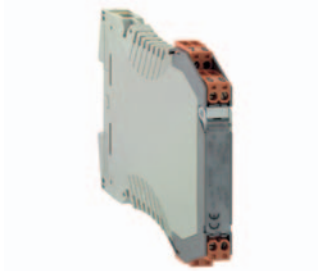

0...20mA/0...10V

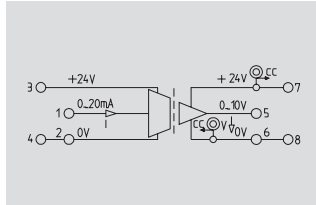

Technical data

Input

Input voltage/Input current
Max. voltage/Max. current
Input resistance voltage/Current

Output

Output voltage/Output current
Load resistance voltage/Current
Accuracy
Temperature coefficient
Step response time
Cut-off freq. (-3dB)

General data

Supply voltage
Current consumption input
Current consumption output
Current-carrying cap. of cross-connect.
Operation temperature
Storage temperature
Approvals

Insulation coordinates

Standards
EMC standards
Rated voltage
Impulse withstand voltage
Isolation voltage Input, output
Overvoltage category
Pollution severity
Clearance & creepage path

/0...20 mA
/25 mA
/50 Ω

/0...20 mA
/< = 500 Ω

+/- 0.2% of final value
≤ 250 ppm/K of final value
≤ 30 ms (typically 16 ms)
≥ 15 Hz (typically 25 Hz)

24 Vdc +/- 20 %
< 11 mA at lin = 20 mA
< 32 mA at lout = 20 mA
≤ 2 A
0 °C...+55 °C (fitted)
-20 °C...+85 °C
CSA / UL/UR / CE / ESD

EN 50178
EN 50081, EN50082, EN55011
300 V
4 kV
1.2 kVeff / 5s
III
2
≥ 3 mm

/0...20 mA
/25 mA
/50 Ω

/4...20 mA
/< = 500 Ω

+/- 0.2% of final value
≤ 250 ppm/K of final value
≤ 30 ms (typically 16 ms)
≥ 15 Hz (typically 25 Hz)

24 Vdc +/- 20 %
< 11 mA at lin = 20 mA
< 32 mA at lout = 20 mA
≤ 2 A
0 °C...+55 °C (fitted)
-20 °C...+85 °C
CSA / UL/UR / CE / ESD

EN 50178
EN 50081, EN50082, EN55011
300 V
4 kV
1.2 kVeff / 5s
III
2
≥ 3 mm

/0...20 mA
/25 mA
/50 Ω

0...10 V/
≥ 1 kΩ

+/- 0.2% of final value
≤ 250 ppm/K of final value
≤ 30 ms (typically 16 ms)
≥ 15 Hz (typically 25 Hz)

24 Vdc +/- 20 %
< 11 mA at lin = 20 mA
< 20 mA at lout = 10 mA
≤ 2 A
0 °C...+55 °C (fitted)
-20 °C...+85 °C
CSA / UL/UR / CE / ESD

EN 50178
EN 50081, EN50082, EN55011
300 V
4 kV
1.2 kVeff / 5s
III
2
≥ 3 mm

Dimensions

Clamping range (rating- / min. / max.) mm²
Length x width x height mm

Information

Screw connection	Tension clamp c.
2.50 / 0.50 / 2.50	1.50 / 0.50 / 2.50
92.4 x 12.5 x 112.4	92.4 x 12.5 x 112.4

Tu=23°C, single module

Screw connection	Tension clamp c.
2.50 / 0.50 / 2.50	1.50 / 0.50 / 2.50
92.4 x 12.5 x 112.4	92.4 x 12.5 x 112.4

Tu=23°C, single module

Screw connection	Tension clamp c.
2.50 / 0.50 / 2.50	1.50 / 0.50 / 2.50
92.4 x 12.5 x 112.4	92.4 x 12.5 x 112.4

Tu=23°C, single module

Ordering data

Type of connection

Screw connection
Tension clamp c.

Type	(Qty.=1)	Order No.
WAS4 CCC DC 0-20/0-20MA		8445070000
WAZ4 CCC DC 0-20/0-20MA		8445080000

Type	(Qty.=1)	Order No.
WAS4 CCC DC 0-20/4-20MA		8446970000
WAZ4 CCC DC 0-20/4-20MA		8446990000

Type	(Qty.=1)	Order No.
WAS4 CVC DC 0-20/0-10V		8447020000
WAZ4 CVC DC 0-20/0-10V		8447030000

Information

Accessories

Information

Voltage supply 24V and 0V with ZQV 2.5N/2 cross-connection

Voltage supply 24V and 0V with ZQV 2.5N/2 cross-connection

Voltage supply 24V and 0V with ZQV 2.5N/2 cross-connection

Articles with coloured order number are kept permanently in stock at the central warehouse in Germany. Delivery times see page X.2

DC/DC 2-way isolator

Double sided power supply

- Signal conversion
- Galvanic isolation between input/output signal
- Power supply can be cross-connected via plug-in jumpers

0...10V/0...20mA

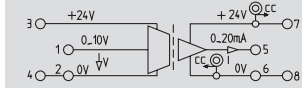

0...10V/4...20mA

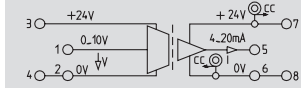

0...10V/0...10V

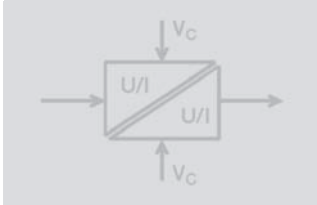
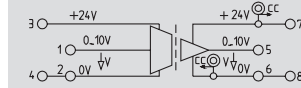

Technical data

Input

Input voltage/Input current
Max. voltage/Max. current
Input resistance voltage/Current

Output

Output voltage/Output current
Load resistance voltage/Current
Accuracy
Temperature coefficient
Step response time
Cut-off freq. (-3dB)

General data

Supply voltage
Current consumption input
Current consumption output
Current-carrying cap. of cross-connect.
Operation temperature
Storage temperature
Approvals

Insulation coordinates

Standards
EMC standards
Rated voltage
Impulse withstand voltage
Isolation voltage Input, output
Overvoltage category
Pollution severity
Clearance & creepage path

0...10 V/
15 V/
500 kΩ/

/0...20 mA
< = 500 Ω
+/- 0.2% of final value
<= 250 ppm/K of final value
<= 30 ms (typically 25 ms)
>= 13 Hz (typically 17 Hz)

24 Vdc +/- 20 %
< 11 mA at U_{in} = 10 V
< 32 mA at I_{out} = 20 mA
<= 2 A
0 °C...+55 °C (fitted)
-20 °C...+85 °C
CSA / UL/UR / CE / ESD

EN 50178
EN 50081, EN50082, EN55011
300 V
4 kV
1.2 kVeff / 5s
III
2
>= 3 mm

0...10 V/
15 V/
500 kΩ/

/4...20 mA
< = 500 Ω
+/- 0.2% of final value
<= 250 ppm/K of final value
<= 30 ms (typically 25 ms)
>= 13 Hz (typically 17 Hz)

24 Vdc +/- 20 %
< 11 mA at U_{in} = 10 V
< 32 mA at I_{out} = 20 mA
<= 2 A
0 °C...+55 °C (fitted)
-20 °C...+85 °C
CSA / UL/UR / CE / ESD

EN 50178
EN 50081, EN50082, EN55011
300 V
4 kV
1.2 kVeff / 5s
III
2
>= 3 mm

0...10 V/
15 V/
500 kΩ/

0...10 V/
>= 1 kΩ/
+/- 0.2% of final value
<= 250 ppm/K of final value
<= 30 ms (typically 25 ms)
>= 13 Hz (typically 17 Hz)

24 Vdc +/- 20 %
< 11 mA at U_{in} = 10 V
< 20 mA at I_{out} = 10 mA
<= 2 A
0 °C...+55 °C (fitted)
-20 °C...+85 °C
CSA / UL/UR / CE / ESD

EN 50178
EN 50081, EN50082, EN55011
300 V
4 kV
1.2 kVeff / 5s
III
2
>= 3 mm

Dimensions

Clamping range (rating- / min. / max.) mm²
Length x width x height mm

Information

Screw connection Tension clamp c.

2.50 / 0.50 / 2.50 1.50 / 0.50 / 2.50
92.4 x 12.5 x 112.4 92.4 x 12.5 x 112.4

Tu=23°C, single module

Screw connection Tension clamp c.

2.50 / 0.50 / 2.50 1.50 / 0.50 / 2.50
92.4 x 12.5 x 112.4 92.4 x 12.5 x 112.4

Tu=23°C, single module

Screw connection Tension clamp c.

2.50 / 0.50 / 2.50 1.50 / 0.50 / 2.50
92.4 x 12.5 x 112.4 92.4 x 12.5 x 112.4

Tu=23°C, single module

Ordering data

Type of connection

Screw connection
Tension clamp c.

Information

Type	(Qty.=1)	Order No.
WAS4 VCC DC 0-10/0-20MA		8447050000
WAZ4 VCC DC 0-10/0-20MA		8447080000

Type	(Qty.=1)	Order No.
WAS4 VCC DC 0-10/4-20MA		8447100000
WAZ4 VCC DC 0-10/4-20MA		8447110000

Type	(Qty.=1)	Order No.
WAS4 VCC DC 0-10/0-10V		8447130000
WAZ4 VCC DC 0-10/0-10V		8447140000

Accessories

Information

Voltage supply 24V and 0V with ZQV 2.5N/2 cross-connection

Voltage supply 24V and 0V with ZQV 2.5N/2 cross-connection

Voltage supply 24V and 0V with ZQV 2.5N/2 cross-connection

DC/DC 3-way isolator

10Hz Cut-off frequency

- Signal conversion
- Galvanic isolation between input/output signal
- Power supply can be cross-connected via plug-in jumpers

0...(4)20mA/0...(4)20mA

0...20mA/4...20mA

0...20mA/0...10V

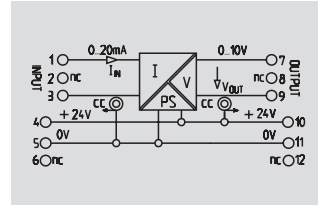
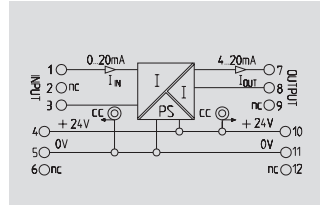
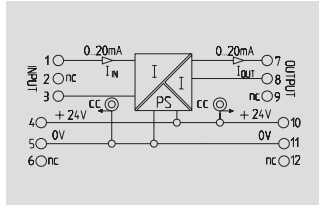
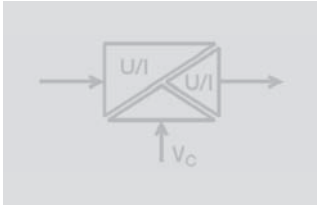

Technical data

Input

Input voltage/Input current
Max. voltage
Max. current

Output

Output voltage/Output current
Load resistance voltage/Current
Accuracy
Temperature coefficient
Step response time
Cut-off freq. (-3dB)

General data

Supply voltage
Power consumption
Current-carrying cap. of cross-connect.
Operation temperature
Storage temperature
Approvals

Insulation coordinates

Standards
EMC standards
Rated voltage
Impulse withstand voltage
Isolation voltage Input, output/
Overvoltage category
Pollution severity
Clearance & creepage path

/0(4)...20 mA

25 mA

/0(4)...20 mA

/ $\leq 600 \Omega$

0.2 %

+/- 250 ppm/K

≤ 45 ms

10 Hz

24 Vdc +/- 25 %

< 1.5 W at Iout = 20 mA

≤ 2 A

0 °C...+55 °C (horiz. mounting)

-20 °C...+85 °C

CE / cURus

EN 50178

EN 50081, EN50082, EN55011

300 V

4 kV

2 kVeff / 5s/

III

2

≥ 3 mm

/0...20 mA

25 mA

/4...20 mA

/ $\leq 600 \Omega$

0.2 %

+/- 250 ppm/K

≤ 45 ms

10 Hz

24 Vdc +/- 25 %

< 1.5 W at Iout = 20 mA

≤ 2 A

0 °C...+55 °C (horiz. mounting)

-20 °C...+85 °C

CE / cURus

EN 50178

EN 50081, EN50082, EN55011

300 V

4 kV

2 kVeff / 5s/

III

2

≥ 3 mm

/0...20 mA

25 mA

0...10 V/

≥ 1 k Ω /

0.2 %

+/- 250 ppm/K

≤ 45 ms

10 Hz

24 Vdc +/- 25 %

< 1.3 W at Iout = 5 mA

≤ 2 A

0 °C...+55 °C (horiz. mounting)

-20 °C...+85 °C

CE / cURus

EN 50178

EN 50081, EN50082, EN55011

300 V

4 kV

2 kVeff / 5s/

III

2

≥ 3 mm

Dimensions

Clamping range (rating- / min. / max.) mm²
Length x width x height mm

Information

Screw connection Tension clamp c.

2.50 / 0.50 / 2.50 1.50 / 0.50 / 2.50
92.4 x 17.5 x 112.4 92.4 x 17.5 x 112.4

Tu=23°C, single module

Screw connection Tension clamp c.

2.50 / 0.50 / 2.50 1.50 / 0.50 / 2.50
92.4 x 17.5 x 112.4 92.4 x 17.5 x 112.4

Tu=23°C, single module

Screw connection Tension clamp c.

2.50 / 0.50 / 2.50 1.50 / 0.50 / 2.50
92.4 x 17.5 x 112.4 92.4 x 17.5 x 112.4

Tu=23°C, single module

Ordering data

Type of connection

Screw connection
Tension clamp c.

Type	(Qty.=1)	Order No.
WAS5 CCC 0-20/0-20mA		8540180000
WAZ5 CCC 0-20/0-20mA		8540190000

Type	(Qty.=1)	Order No.
WAS5 CCC 0-20/4-20mA		8540250000
WAZ5 CCC 0-20/4-20mA		8540260000

Type	(Qty.=1)	Order No.
WAS5 CVC 0-20mA/0-10V		8540270000
WAZ5 CVC 0-20mA/0-10V		8540280000

Information

Accessories

Information

Voltage supply 24V and 0V with ZQV 2.5N/2 cross-connection

Voltage supply 24V and 0V with ZQV 2.5N/2 cross-connection

Voltage supply 24V and 0V with ZQV 2.5N/2 cross-connection

Articles with coloured order number are kept permanently in stock at the central warehouse in Germany. Delivery times see page X.2

DC/DC 3-way isolator

10Hz Cut-off frequency

- Signal conversion
- Galvanic isolation between input/output signal
- Power supply can be cross-connected via plug-in jumpers

4...20mA/0...20mA

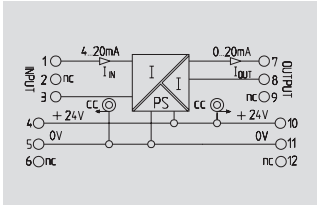

4...20mA/0...10V

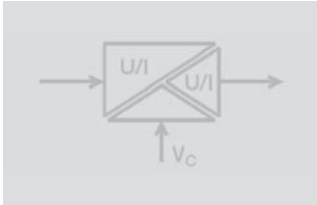
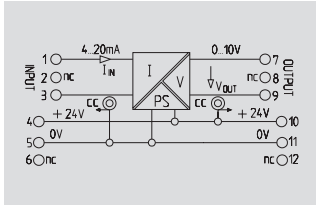

Technical data

Input

Input voltage/Input current
Max. voltage
Max. current

Output

Output voltage/Output current
Load resistance voltage/Current
Accuracy
Temperature coefficient
Step response time
Cut-off freq. (-3dB)

General data

Supply voltage
Power consumption
Current-carrying cap. of cross-connect.
Operation temperature
Storage temperature
Approvals

Insulation coordinates

Standards
EMC standards
Rated voltage
Impulse withstand voltage
Isolation voltage Input, output/
Overvoltage category
Pollution severity
Clearance & creepage path

4...20 mA

25 mA

0...20 mA

<= 600 Ω

0.2 %

+/- 250 ppm/K

<= 45 ms

10 Hz

24 Vdc +/- 25 %

< 1.5 W at Iout = 20 mA

<= 2 A

0 °C...+55 °C (horiz. mounting)

-20 °C...+85 °C

CE / cURus

EN 50178

EN 50081, EN50082, EN55011

300 V

4 kV

2 kVeff / 5s/

III

2

>= 3 mm

4...20 mA

25 mA

0...10 V/

>= 1 kΩ/

0.2 %

+/- 250 ppm/K

<= 45 ms

10 Hz

24 Vdc +/- 25 %

< 1.3 W at Iout = 5 mA

<= 2 A

0 °C...+55 °C (horiz. mounting)

-20 °C...+85 °C

CE / cURus

EN 50178

EN 50081, EN50082, EN55011

300 V

4 kV

2 kVeff / 5s/

III

2

>= 3 mm

Dimensions

Clamping range (rating- / min. / max.) mm²
Length x width x height mm

Information

Screw connection Tension clamp c.

2.50 / 0.50 / 2.50 1.50 / 0.50 / 2.50
92.4 x 17.5 x 112.4 92.4 x 17.5 x 112.4

Tu=23°C, single module

Screw connection Tension clamp c.

2.50 / 0.50 / 2.50 1.50 / 0.50 / 2.50
92.4 x 17.5 x 112.4 92.4 x 17.5 x 112.4

Tu=23°C, single module

Ordering data

Type of connection

Screw connection
Tension clamp c.

Type	(Qty.=1)	Order No.
WAS5 CCC 4-20/0-20mA		8540200000
WAZ5 CCC 4-20/0-20mA		8540210000

Type	(Qty.=1)	Order No.
WAS5 CVC 4-20mA/0-10V		8540230000
WAZ5 CVC 4-20mA/0-10V		8540240000

Information

Accessories

Information

Voltage supply 24V and 0V with ZQV 2.5N/2 cross-connection

Voltage supply 24V and 0V with ZQV 2.5N/2 cross-connection

DC/DC 3-way isolator

10Hz Cut-off frequency

- Signal conversion
- Galvanic isolation between input/output signal
- Power supply can be cross-connected via plug-in jumpers

0...10V/0...20mA

0...10V/4...20mA

0...10V/0...10V

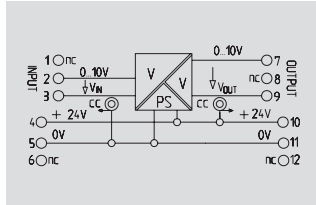
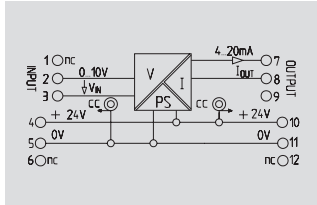
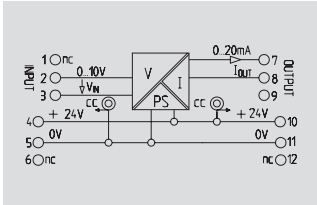
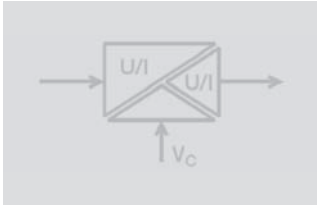

Technical data

Input

Input voltage/Input current
Max. voltage
Max. current

Output

Output voltage/Output current
Load resistance voltage/Current
Accuracy
Temperature coefficient
Step response time
Cut-off freq. (-3dB)

General data

Supply voltage
Power consumption
Current-carrying cap. of cross-connect.
Operation temperature
Storage temperature
Approvals

Insulation coordinates

Standards
EMC standards
Rated voltage
Impulse withstand voltage
Isolation voltage Input, output/
Overvoltage category
Pollution severity
Clearance & creepage path

0...10 V/
15 V

/0...20 mA
< = 600 Ω
0.2 %
+/- 250 ppm/K
<= 45 ms
10 Hz

24 Vdc +/- 25 %
< 1.5 W at Iout = 20 mA
<= 2 A
0 °C...+55 °C (horiz. mounting)
-20 °C...+85 °C
CE / cURus

EN 50178
EN 50081, EN50082, EN55011
300 V
4 kV
2 kVeff / 5s/
III
2
>= 3 mm

0...10 V/
15 V

/4...20 mA
< = 600 Ω
0.2 %
+/- 250 ppm/K
<= 45 ms
10 Hz

24 Vdc +/- 25 %
< 1.5 W at Iout = 20 mA
<= 2 A
0 °C...+55 °C (horiz. mounting)
-20 °C...+85 °C
CE / cURus

EN 50178
EN 50081, EN50082, EN55011
300 V
4 kV
2 kVeff / 5s/
III
2
>= 3 mm

0...10 V/
15 V

0...10 V/
>= 1 kΩ/
0.2 %
+/- 250 ppm/K
<= 45 ms
10 Hz

24 Vdc +/- 25 %
< 1.3 W at Iout = 5 mA
<= 2 A
0 °C...+55 °C (horiz. mounting)
-20 °C...+85 °C
CE / cURus

EN 50178
EN 50081, EN50082, EN55011
300 V
4 kV
2 kVeff / 5s/
III
2
>= 3 mm

Dimensions

Clamping range (rating- / min. / max.) mm²
Length x width x height mm

Information

Screw connection Tension clamp c.

2.50 / 0.50 / 2.50 1.50 / 0.50 / 2.50
92.4 x 17.5 x 112.4 92.4 x 17.5 x 112.4

Tu=23°C, single module

Screw connection Tension clamp c.

2.50 / 0.50 / 2.50 1.50 / 0.50 / 2.50
92.4 x 17.5 x 112.4 92.4 x 17.5 x 112.4

Tu=23°C, single module

Screw connection Tension clamp c.

2.50 / 0.50 / 2.50 1.50 / 0.50 / 2.50
92.4 x 17.5 x 112.4 92.4 x 17.5 x 112.4

Tu=23°C, single module

Ordering data

Type of connection

Screw connection
Tension clamp c.

Type	(Qty.=1)	Order No.
WAS5 VCC 0-10V/0-20MA		8540310000
WAZ5 VCC 0-10V/0-20MA		8540320000

Type	(Qty.=1)	Order No.
WAS5 VCC 0-10V/4-20MA		8540290000
WAZ5 VCC 0-10V/4-20MA		8540300000

Type	(Qty.=1)	Order No.
WAS5 VCC 0-10V/0-10V		8540330000
WAZ5 VCC 0-10V/0-10V		8540340000

Information

Accessories

Information

Voltage supply 24V and 0V with ZQV 2.5N/2 cross-connection

Voltage supply 24V and 0V with ZQV 2.5N/2 cross-connection

Voltage supply 24V and 0V with ZQV 2.5N/2 cross-connection

DC/DC 3-way isolator

20kHz Cut-off frequency

- Signal conversion
- Galvanic isolation between input/output signal
- Power supply can be cross-connected via plug-in jumpers

0(4)...20mA/0(4)...20mA

0...20mA/4...20mA

0...20mA/0...10V

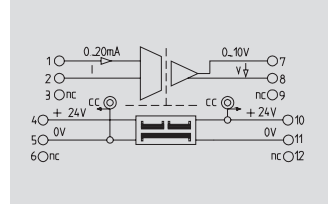
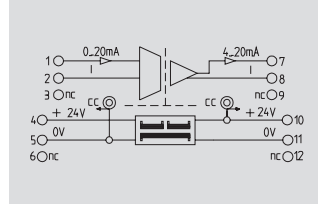
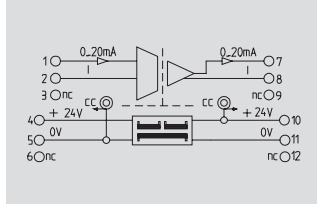
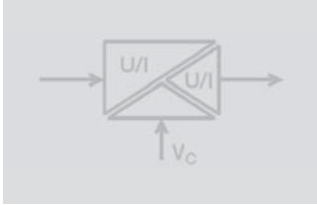

Technical data

Input

Input voltage/Input current
Max. voltage/Max. current
Input resistance voltage/Current

Output

Output voltage/Output current
Load resistance voltage/Current
Accuracy
Temperature coefficient
Step response time
Cut-off freq. (-3dB)

General data

Supply voltage
Power consumption
Current-carrying cap. of cross-connect.
Operation temperature
Storage temperature
Approvals

Insulation coordinates

Standards
EMC standards
Rated voltage
Impulse withstand voltage
Isolation voltage Input, output
Coupling cap. in- resp. output/power supply
Overvoltage category
Pollution severity
Clearance & creepage path

/0...20 mA
/50 mA
/50 Ω

/0...20 mA
/< = 600 Ω
< 0.2 % of final value
≤ 250 ppm/K of final value
≤ 40 μs (type 30 μs)
≥ 15 kHz (typ. 20 kHz)

24 Vdc +/- 25 %
< 1.5 W at I_{out} = 20 mA
≤ 2 A
0 °C...+55 °C
-20 °C...+85 °C
CSA / UL/UR / CE / ESD

EN 50178
EN 50081, EN50082, EN55011

300 V
4 kV
1.2 kVeff / 5s
1 nF
III
2
≥ 3 mm

/0...20 mA
/50 mA
/50 Ω

/4...20 mA
/< = 600 Ω
< 0.2 % of final value
≤ 250 ppm/K of final value
≤ 40 μs (type 30 μs)
≥ 15 kHz (typ. 20 kHz)

24 Vdc +/- 25 %
< 1.5 W at I_{out} = 20 mA
≤ 2 A
0 °C...+55 °C
-20 °C...+85 °C
CSA / UL/UR / CE / ESD

EN 50178
EN 50081, EN50082, EN55011

300 V
4 kV
1.2 kVeff / 5s
1 nF
III
2
≥ 3 mm

/0...20 mA
/50 mA
/50 Ω

0...10 V/
≥ 2 kΩ/
< 0.2 % of final value
≤ 250 ppm/K of final value
≤ 40 μs (type 30 μs)
≥ 15 kHz (typ. 20 kHz)

24 Vdc +/- 25 %
< 1.3 W at I_{out} = 5 mA
≤ 2 A
0 °C...+55 °C
-20 °C...+85 °C
CSA / UL/UR / CE / ESD

EN 50178
EN 50081, EN50082, EN55011

300 V
4 kV
1.2 kVeff / 5s
1 nF
III
2
≥ 3 mm

Dimensions

Clamping range (rating- / min. / max.) mm²
Length x width x height mm

Information

Screw connection Tension clamp c.

2.50 / 0.50 / 2.50 1.50 / 0.50 / 2.50
92.4 x 17.5 x 112.4 92.4 x 17.5 x 112.4

Tu=23°C, single module

Screw connection Tension clamp c.

2.50 / 0.50 / 2.50 1.50 / 0.50 / 2.50
92.4 x 17.5 x 112.4 92.4 x 17.5 x 112.4

Tu=23°C, single module

Screw connection Tension clamp c.

2.50 / 0.50 / 2.50 1.50 / 0.50 / 2.50
92.4 x 17.5 x 112.4 92.4 x 17.5 x 112.4

Tu=23°C, single module

Ordering data

Type of connection

Screw connection
Tension clamp c.

Type	(Qty.=1)	Order No.
WAS5 CCC HF 0-20/0-20MA		8447160000
WAZ5 CCC HF 0-20/0-20MA		8447170000

Type	(Qty.=1)	Order No.
WAS5 CCC HF 0-20/4-20MA		8447190000
WAZ5 CCC HF 0-20/4-20MA		8447200000

Type	(Qty.=1)	Order No.
WAS5 CVC HF 0-20/0-10V		8447220000
WAZ5 CVC HF 0-20/0-10V		8447230000

Information

Accessories

Information

Voltage supply 24V and 0V with ZQV 2.5N/2 cross-connection

Voltage supply 24V and 0V with ZQV 2.5N/2 cross-connection

Voltage supply 24V and 0V with ZQV 2.5N/2 cross-connection

DC/DC 3-way isolator

20kHz Cut-off frequency

- Signal conversion
- Galvanic isolation between input/output signal
- Power supply can be cross-connected via plug-in jumpers

4...20mA/0...20mA

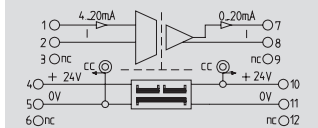

4...20mA/0...10V

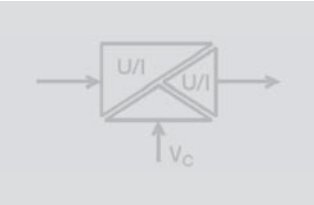
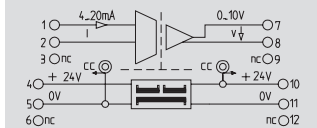

Technical data

Input

Input voltage/Input current
Max. voltage/Max. current
Input resistance voltage/Current

Output

Output voltage/Output current
Load resistance voltage/Current
Accuracy
Temperature coefficient
Step response time
Cut-off freq. (-3dB)

General data

Supply voltage
Power consumption
Current-carrying cap. of cross-connect.
Operation temperature
Storage temperature
Approvals

Insulation coordinates

Standards
EMC standards
Rated voltage
Impulse withstand voltage
Isolation voltage Input, output
Coupling cap. in- resp. output/power supply
Overvoltage category
Pollution severity
Clearance & creepage path

Dimensions

Clamping range (rating- / min. / max.) mm²
Length x width x height mm

Information

Ordering data

Type of connection

Screw connection
Tension clamp c.

Information

Accessories

Information

/4...20 mA
/50 mA
/50 Ω

/0...20 mA
/< = 600 Ω
< 0.2 % of final value
<= 250 ppm/K of final value
<= 40 μs (type 30 μs)
>= 15 kHz (typ. 20 kHz)

24 Vdc +/- 25 %
< 1.5 W at Iout = 20 mA
<= 2 A
0 °C...+55 °C
-20 °C...+85 °C
CSA / UL/UR / CE / ESD

EN 50178
EN 50081, EN50082, EN55011

300 V
4 kV
1.2 kVeff / 5s
1 nF
III
2
>= 3 mm

Screw connection Tension clamp c.

2.50 / 0.50 / 2.50 1.50 / 0.50 / 2.50
92.4 x 17.5 x 112.4 92.4 x 17.5 x 112.4

Tu=23°C, single module

Type	(Qty.=1)	Order No.
WAS5 CCC HF 4-20/0-20MA		8447250000
WAZ5 CCC HF 4-20/0-20MA		8447260000

Voltage supply 24V and 0V with ZQV 2.5N/2 cross-connection

/4...20 mA
/50 mA
/50 Ω

0...10 V/
>= 2 kΩ/< = 600 Ω
< 0.2 % of final value
<= 250 ppm/K of final value
<= 40 μs (type 30 μs)
>= 15 kHz (typ. 20 kHz)

24 Vdc +/- 25 %
< 1.3 W at Iout = 5 mA
<= 2 A
0 °C...+55 °C
-20 °C...+85 °C
CSA / UL/UR / CE / ESD

EN 50178
EN 50081, EN50082, EN55011

300 V
4 kV
1.2 kVeff / 5s
1 nF
III
2
>= 3 mm

Screw connection Tension clamp c.

2.50 / 0.50 / 2.50 1.50 / 0.50 / 2.50
92.4 x 17.5 x 112.4 92.4 x 17.5 x 112.4

Tu=23°C, single module

Type	(Qty.=1)	Order No.
WAS5 CVC HF 4-20/0-10V		8447280000
WAZ5 CVC HF 4-20/0-10V		8447290000

Voltage supply 24V and 0V with ZQV 2.5N/2 cross-connection

DC/DC 3-way isolator

20kHz Cut-off frequency

- Signal conversion
- Galvanic isolation between input/output signal
- Power supply can be cross-connected via plug-in jumpers

0...10V/0...20mA



0...10V/4...20mA

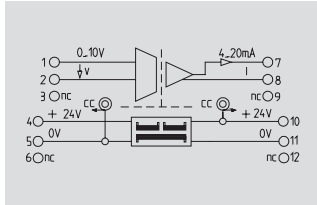
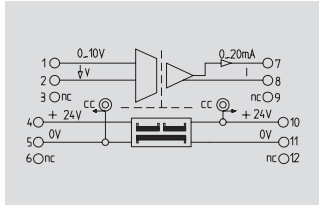
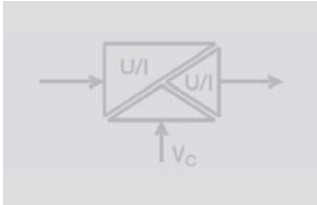

Technical data

Input

Input voltage/Input current
Max. voltage/Max. current
Input resistance voltage/Current

Output

Output voltage/Output current
Load resistance voltage/Current
Accuracy
Temperature coefficient
Step response time
Cut-off freq. (-3dB)

General data

Supply voltage
Power consumption
Current-carrying cap. of cross-connect.
Operation temperature
Storage temperature
Approvals

Insulation coordinates

Standards
EMC standards
Rated voltage
Impulse withstand voltage
Isolation voltage Input, output
Coupling cap. in- resp. output/power supply
Overvoltage category
Pollution severity
Clearance & creepage path

0...10 V/
15 V/
500 kΩ/

/0...20 mA
< = 600 Ω
+/- 0.2% of final value
<= 250 ppm/K of final value
<= 40 μs (type 30 μs)
>= 15 kHz (typ. 20 kHz)

24 Vdc +/- 25 %
< 1.5 W at Iout = 20 mA
<= 2 A
0 °C...+55 °C
-20 °C...+85 °C
CSA / UL/UR / CE / ESD

EN 50178
EN 50081, EN50082, EN55011
300 V
4 kV
1.2 kVeff / 5s
1 nF
III
2
>= 3 mm

0...10 V/
15 V/
500 kΩ/

/4...20 mA
< = 600 Ω
+/- 0.2% of final value
<= 250 ppm/K of final value
<= 40 μs (type 30 μs)
>= 15 kHz (typ. 20 kHz)

24 Vdc +/- 25 %
< 1.5 W at Iout = 20 mA
<= 2 A
0 °C...+55 °C
-20 °C...+85 °C
CSA / UL/UR / CE / ESD

EN 50178
EN 50081, EN50082, EN55011
300 V
4 kV
1.2 kVeff / 5s
1 nF
III
2
>= 3 mm

Dimensions

Clamping range (rating- / min. / max.) mm²
Length x width x height mm

Information

Screw connection Tension clamp c.

2.50 / 0.50 / 2.50 1.50 / 0.50 / 2.50
92.4 x 17.5 x 112.4 92.4 x 17.5 x 112.4

Tu=23°C, single module

Screw connection Tension clamp c.

2.50 / 0.50 / 2.50 1.50 / 0.50 / 2.50
92.4 x 17.5 x 112.4 92.4 x 17.5 x 112.4

Tu=23°C, single module

Ordering data

Type of connection

Screw connection
Tension clamp c.

Type	(Qty.=1)	Order No.
WAS5 VCC HF 0-10/0-20MA		8447310000
WAZ5 VCC HF 0-10/0-20MA		8447320000

Type	(Qty.=1)	Order No.
WAS5 VCC HF 0-10/4-20MA		8447340000
WAZ5 VCC HF 0-10/4-20MA		8447350000

Information

Accessories

Information

Voltage supply 24V and 0V with ZQV 2.5N/2 cross-connection

Voltage supply 24V and 0V with ZQV 2.5N/2 cross-connection

DC/DC 3-way isolator

20kHz Cut-off frequency

- Signal conversion
- Galvanic isolation between input/output signal
- Power supply can be cross-connected via plug-in jumpers

0...10V/0...10V

-10V...+10V/-10V...+10V

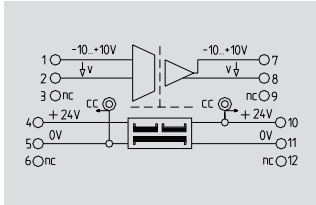
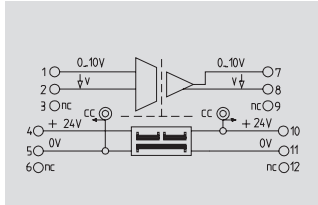
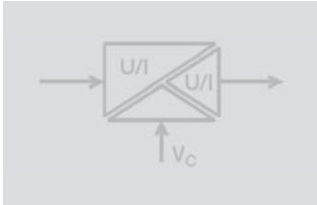

Technical data

Input

Input voltage/Input current
Max. voltage/Max. current
Input resistance voltage/Current

Output

Output voltage/Output current
Load resistance voltage/Current
Accuracy
Temperature coefficient
Step response time
Cut-off freq. (-3dB)

General data

Supply voltage
Power consumption
Current-carrying cap. of cross-connect.
Operation temperature
Storage temperature
Approvals

Insulation coordinates

Standards
EMC standards
Rated voltage
Impulse withstand voltage
Isolation voltage Input, output
Coupling cap. in- resp. output/power supply
Overvoltage category
Pollution severity
Clearance & creepage path

0...10 V/
15 V/
500 kΩ/

0...10 V/
≥ 2 kΩ/
± 0.2% of final value
≤ 250 ppm/K of final value
≤ 40 μs (type 30 μs)
≥ 15 kHz (typ. 20 kHz)

24 Vdc ± 25 %
< 1.3 W at I_{out} = 5 mA
≤ 2 A
0 °C...+55 °C
-20 °C...+85 °C
CSA / UL/UR / CE / ESD

EN 50178
EN 50081, EN50082, EN55011
300 V
4 kV
1.2 kVeff / 5s
1 nF
III
2
≥ 3 mm

-10...+10 V/
± 15 V/
500 kΩ/

-10...+10 V/
≥ 2 kΩ/
± 0.2 % of measuring range
≤ 250 ppm/K of measuring range
≤ 40 μs (type 30 μs)
≥ 15 kHz (typ. 20 kHz)

24 Vdc ± 25 %
< 1.3 W at I_{out} = 5 mA
≤ 2 A
0 °C...+55 °C
-20 °C...+85 °C
CE / ESD / cURus

EN 50178
EN 50081, EN50082, EN55011
300 V
4 kV
1.2 kVeff / 5s
1 nF
III
2
≥ 3 mm

Dimensions

Clamping range (rating- / min. / max.) mm²
Length x width x height mm

Information

Screw connection Tension clamp c.

2.50 / 0.50 / 2.50 1.50 / 0.50 / 2.50
92.4 x 17.5 x 112.4 92.4 x 17.5 x 112.4

Tu=23°C, single module

Screw connection Tension clamp c.

2.50 / 0.50 / 2.50 1.50 / 0.50 / 2.50
92.4 x 17.5 x 112.4 92.4 x 17.5 x 112.4

Tu=23°C, single module

Ordering data

Type of connection

Screw connection
Tension clamp c.

Type	(Qty.=1)	Order No.
WAS5 VVC HF 0-10/0-10V		8447370000
WAZ5 VVC HF 0-10/0-10V		8447380000

Type	(Qty.=1)	Order No.
WAS5 VVC HF +10V/+10V		8561610000
WAZ5 VVC HF +10V/+10V		8587000000

Information

Accessories

Information

Voltage supply 24V and 0V with ZQV 2.5N/2 cross-connection

Voltage supply 24V and 0V with ZQV 2.5N/2 cross-connection

DC/DC 3-way isolator

Configurable

- Universal adjustable via DIP-switch
- Service tool WAVETOOL via internet
- Voltage supply 20...230 V ac/dc
- Low power loss
- Adjustable transmission frequency

PRO DC/DC

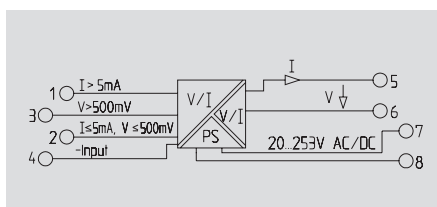
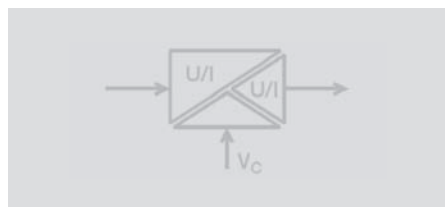

Switch position/setting options

Input	Switch							
	S1				S2			
Input range	1	2	3	4	1	2	3	4
0 ... ±60 mV	<input type="checkbox"/>	<input type="checkbox"/>	<input type="checkbox"/>	<input type="checkbox"/>	<input type="checkbox"/>	<input type="checkbox"/>	<input type="checkbox"/>	<input type="checkbox"/>
0 ... ±100 mV	<input checked="" type="checkbox"/>	<input type="checkbox"/>	<input type="checkbox"/>	<input type="checkbox"/>	<input type="checkbox"/>	<input type="checkbox"/>	<input type="checkbox"/>	<input checked="" type="checkbox"/>
0 ... ±150 mV	<input type="checkbox"/>	<input checked="" type="checkbox"/>	<input type="checkbox"/>	<input type="checkbox"/>	<input type="checkbox"/>	<input type="checkbox"/>	<input type="checkbox"/>	<input checked="" type="checkbox"/>
0 ... ±300 mV	<input checked="" type="checkbox"/>	<input checked="" type="checkbox"/>	<input type="checkbox"/>	<input type="checkbox"/>	<input type="checkbox"/>	<input type="checkbox"/>	<input type="checkbox"/>	<input checked="" type="checkbox"/>
0 ... ±500 mV	<input type="checkbox"/>	<input type="checkbox"/>	<input checked="" type="checkbox"/>	<input type="checkbox"/>	<input type="checkbox"/>	<input type="checkbox"/>	<input type="checkbox"/>	<input checked="" type="checkbox"/>
0 ... ±1 V	<input checked="" type="checkbox"/>	<input type="checkbox"/>	<input checked="" type="checkbox"/>	<input type="checkbox"/>	<input type="checkbox"/>	<input checked="" type="checkbox"/>	<input type="checkbox"/>	<input checked="" type="checkbox"/>
0 ... ±5 V	<input type="checkbox"/>	<input checked="" type="checkbox"/>	<input checked="" type="checkbox"/>	<input type="checkbox"/>	<input type="checkbox"/>	<input checked="" type="checkbox"/>	<input checked="" type="checkbox"/>	<input type="checkbox"/>
0 ... ±10 V	<input checked="" type="checkbox"/>	<input checked="" type="checkbox"/>	<input type="checkbox"/>	<input type="checkbox"/>	<input type="checkbox"/>	<input checked="" type="checkbox"/>	<input checked="" type="checkbox"/>	<input type="checkbox"/>
0 ... ±100 V	<input type="checkbox"/>	<input type="checkbox"/>	<input type="checkbox"/>	<input type="checkbox"/>	<input type="checkbox"/>	<input type="checkbox"/>	<input type="checkbox"/>	<input checked="" type="checkbox"/>
0 ... ±-0.3 mA	<input checked="" type="checkbox"/>	<input type="checkbox"/>	<input type="checkbox"/>	<input checked="" type="checkbox"/>	<input checked="" type="checkbox"/>	<input type="checkbox"/>	<input type="checkbox"/>	<input type="checkbox"/>
0 ... ±1 mA	<input type="checkbox"/>	<input checked="" type="checkbox"/>	<input type="checkbox"/>	<input checked="" type="checkbox"/>	<input checked="" type="checkbox"/>	<input type="checkbox"/>	<input type="checkbox"/>	<input type="checkbox"/>
0 ... ±5 mA	<input checked="" type="checkbox"/>	<input checked="" type="checkbox"/>	<input checked="" type="checkbox"/>	<input checked="" type="checkbox"/>	<input type="checkbox"/>	<input type="checkbox"/>	<input type="checkbox"/>	<input type="checkbox"/>
0 ... ±10 mA	<input type="checkbox"/>	<input type="checkbox"/>	<input type="checkbox"/>	<input type="checkbox"/>	<input type="checkbox"/>	<input type="checkbox"/>	<input type="checkbox"/>	<input checked="" type="checkbox"/>
0 ... ±20 mA	<input checked="" type="checkbox"/>	<input type="checkbox"/>	<input type="checkbox"/>	<input checked="" type="checkbox"/>	<input checked="" type="checkbox"/>	<input type="checkbox"/>	<input type="checkbox"/>	<input type="checkbox"/>
0 ... ±50 mA	<input type="checkbox"/>	<input type="checkbox"/>	<input type="checkbox"/>	<input type="checkbox"/>	<input type="checkbox"/>	<input type="checkbox"/>	<input type="checkbox"/>	<input checked="" type="checkbox"/>
4 ... ±20 mA*	<input checked="" type="checkbox"/>	<input checked="" type="checkbox"/>	<input checked="" type="checkbox"/>	<input checked="" type="checkbox"/>	<input type="checkbox"/>	<input type="checkbox"/>	<input type="checkbox"/>	<input type="checkbox"/>

*Offset conversion not calibrated

Switch S2		4
calibratet ranges		<input checked="" type="checkbox"/>
Span-pot. activated: input x 0.33 ... x 3.30		<input type="checkbox"/>

Output	Switch					
	S1			S3		
Output range	5	6	7	1	2	
0 ... ±10 V	<input type="checkbox"/>	<input type="checkbox"/>	<input type="checkbox"/>	<input checked="" type="checkbox"/>	<input checked="" type="checkbox"/>	
2 ... 10 V	<input checked="" type="checkbox"/>	<input type="checkbox"/>	<input type="checkbox"/>	<input checked="" type="checkbox"/>	<input checked="" type="checkbox"/>	
0 ... ±5 V	<input type="checkbox"/>	<input checked="" type="checkbox"/>	<input type="checkbox"/>	<input checked="" type="checkbox"/>	<input checked="" type="checkbox"/>	
1 ... 5 V	<input checked="" type="checkbox"/>	<input checked="" type="checkbox"/>	<input type="checkbox"/>	<input checked="" type="checkbox"/>	<input checked="" type="checkbox"/>	
0 ... ±20 mA	<input type="checkbox"/>	<input type="checkbox"/>	<input checked="" type="checkbox"/>	<input type="checkbox"/>	<input type="checkbox"/>	
4 ... 20 mA	<input checked="" type="checkbox"/>	<input type="checkbox"/>	<input checked="" type="checkbox"/>	<input type="checkbox"/>	<input type="checkbox"/>	

Offset	Switch				
	S1			S2	
(in % of output voltage)	8	9	10	5	
0 %	<input type="checkbox"/>	<input type="checkbox"/>	<input type="checkbox"/>	<input checked="" type="checkbox"/>	
-100 %	<input checked="" type="checkbox"/>	<input type="checkbox"/>	<input type="checkbox"/>	<input checked="" type="checkbox"/>	
-50 %	<input type="checkbox"/>	<input checked="" type="checkbox"/>	<input type="checkbox"/>	<input checked="" type="checkbox"/>	
+50 %	<input checked="" type="checkbox"/>	<input type="checkbox"/>	<input type="checkbox"/>	<input checked="" type="checkbox"/>	
+100 %	<input type="checkbox"/>	<input type="checkbox"/>	<input checked="" type="checkbox"/>	<input checked="" type="checkbox"/>	

Zero pot. activated: additional ±25 %

Switch S3		3
Bandwidth 10 kHz		<input type="checkbox"/>
Bandwidth 10 Hz		<input checked="" type="checkbox"/>
Set range can be documented on side of housing.		<input type="checkbox"/>

■ = on
□ = off

Technical data

Input		
Input voltage/Input current	+/- 20 mV...+/- 200 V/+/-0.1mA...+/- 100 mA	
Input resistance voltage/Current	ca. 1 MΩ/< 5 mA: ca. 100 Ω; >5 mA: ca. 5 Ω	
Max. current	lin < 5mA: < 100mA, lin > 5mA < 300mA	
Output		
Output voltage/Output current	0...+/- 10 V/0...+/- 20 mA	
Load resistance voltage/Current	>= 1 kΩ/< = 600 Ω	
Accuracy	< 0.1 % of final value	
Temperature coefficient	< 60 ppm/K of end value	
Cut-off freq. (-3dB)	> 10 kHz/ < 10 Hz	
Offset	20 µA resp. 10 mV	
Adjustment range, zero point	+25 % of measuring range of the chosen output range	
Adjustment range, amplification	0.33...3.30 x final value of the chosen output range	
Displacement	-100%, -50%, 0%, 50%, 100% of measuring range	
General data		
Supply voltage	22...230 Vac/dc +10 %/ 48...62 Hz	
Power consumption	approx. 1 W	
Operation temperature	-10 °C...+70 °C	
Storage temperature	-40 °C...+85 °C	
Default settings	0...10V / 0...10V / 10Hz	
Approvals	GL / CE / cURus	
Insulation coordinates		
Standards	EN 50178	
EMC standards	DIN EN 61326, EN 61326/A1, EN 50081-2, EN 61000-6-2	
Rated voltage	600 V	
Impulse withstand voltage	5 kV, 1.2/50 µs (IEC 255-4)	
Isolation voltage Input, output/	4 kVeff/	
Overvoltage category	III	
Pollution severity	2	
Dimensions		
Clamping range (rating- / min. / max.)	mm ²	2.50 / 0.50 / 2.50
Length x width x height	mm	92.4 x 12.5 x 112.4
Information		Tu=23°C, single module
Ordering data		
Type of connection		
Screw connection	Type	Qty. Order No.
Tension clamp c.	WAS4 PRO DC/DC	1 8560740000
	WAZ4 PRO DC/DC	1 8560750000
Information		
Accessories		
Information		Information accessories

DC/DC 3-way isolator

Configurable

- 3-way isolation
- DIP-switch
- Power supply can be cross connected
- Low power loss

DC/DC select

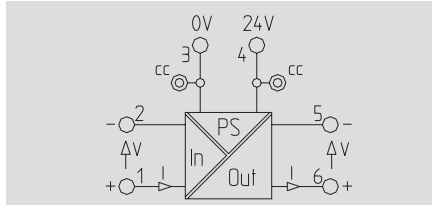
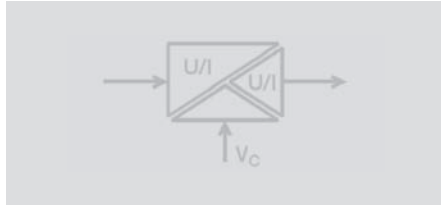
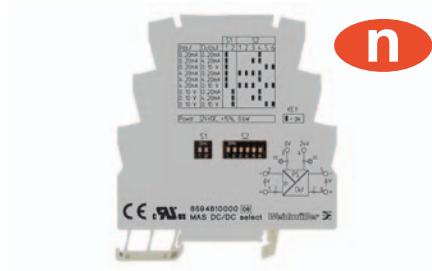

Technical data

Input

Input voltage/Input current
Input resistance voltage/Current
Voltage drop

Output

Output voltage/Output current
Load resistance voltage/Current
Accuracy
Temperature coefficient
Cut-off freq. (-3dB)

General data

Supply voltage
Power consumption
Current-carrying cap. of cross-connect.
Operation temperature
Storage temperature
Default settings
Approvals

Insulation coordinates

Standards
EMC standards
Rated voltage
Isolation voltage Input, output/
Overvoltage category
Pollution severity

0...10 V/0(4)...20 mA
100 kΩ/
< 0.1 V at I _{in} =20 mA (Current Input)
0...10 V/0(4)...20 mA
>= 10 kΩ/< = 600 Ω
< 0.5% of final value
< 150 ppm/K of final value
> 100 Hz
24 Vdc +/- 15 %
approx. 0.6 W
<= 20 A
0 °C...+55 °C
-20 °C...+85 °C
0...20mA / 0...20mA
CE / cURus
EN 50178
DIN EN 61326
50 V
500 Veff/
II
2

Dimensions

Clamping range (rating- / min. / max.) mm²
Length x width x height mm

Information

Screw connection

2.50 / 0.50 / 2.50 1.50 / 0.50 / 2.50

Tension clamp c.

T_u=23°C, single module

Ordering data

Type of connection

Screw connection
Tension clamp c.

Type	Qty.	Order No.
MAS DC/DC select	10	8594810000
MAZ DC/DC select	1	8594840000

Information

Accessories

Information

Information accessoriesVoltage supply 24V and 0V with ZQV 4N/x cross-connection

Switch position/setting options

Input	Output	Switch							
		S1		S2					
		1	2	1	2	3	4	5	6
0 ... 20 mA	0 ... 20 mA	■	□	□	□	□	■	□	□
0 ... 20 mA	4 ... 20 mA	■	□	□	□	□	■	□	□
0 ... 20 mA	0 ... 10 V	■	□	□	□	□	■	□	□
4 ... 20 mA	0 ... 20 mA	■	□	■	■	■	■	□	□
4 ... 20 mA	4 ... 20 mA	■	□	□	□	□	■	□	□
4 ... 20 mA	0 ... 10 V	■	□	□	□	□	■	□	□
0 ... 10 V	0 ... 20 mA	□	■	□	□	□	■	□	□
0 ... 10 V	4 ... 20 mA	□	■	□	□	□	■	□	□
0 ... 10 V	0 ... 10 V	□	■	□	□	□	■	□	□

■ = on
□ = off

Connection

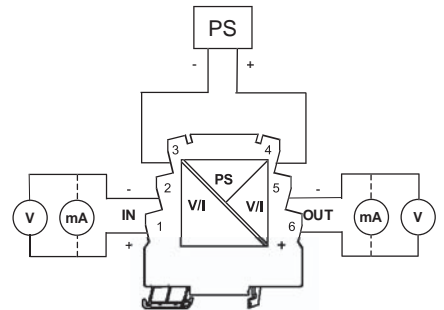

Supply isolator

Without HART

- 2-conductor technology
- 3-way isolation
- Voltage supply cross-connection

MAS RPS

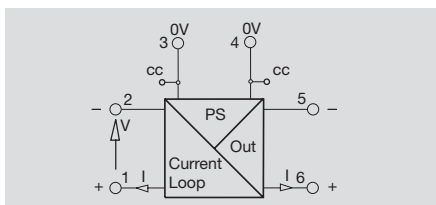

Technical data

Input

Input current
Sensor
Feed voltage

4...20 mA (sensor circuit)
2-conductor
16.5 V / constant for 3...22 mA

Output

Output current
Output signal limit
Load resistance voltage/Current
Accuracy
Offset current
Temperature coefficient
Residual ripple

4...20 mA
22...25 mA
/ R_L = 600 Ω
<math>< 0.1\%</math>
<math>< 30\ \mu\text{A}</math>
<math>< 50\ \text{ppm/K}</math>
<math>< 10\ \text{mVeff}</math>

General data

Supply voltage
Power consumption
Current-carrying cap. of cross-connect.
Operation temperature
Storage temperature
Approvals

24 Vdc +/- 15 %
approx. 1 W
$\leq 20\ \text{A}$
0 °C...+55 °C
-25 °C...+85 °C
CE / cURus

Insulation coordinates

Standards
EMC standards
Rated voltage
Isolation voltage Input, output
Overvoltage category
Pollution severity

EN 50178
DIN EN 61326 class B
300 V
1.5 kVac
II
2

Dimensions

Clamping range (rating- / min. / max.) mm²
Length x width x height mm

Screw connection

2.50 / 0.50 / 2.50
88.0 x 6.1 x 97.8

Information

Ordering data

Type of connection

Screw connection

Type	Qty.	Order No.
MAS RPS	1	8721150000

Information

Accessories

Information

Voltage supply 24V and 0V with ZQV 4N/x cross-connection

Supply isolator

With HART

- 2-conductor technology
- 3-way isolation
- With Hart transmission
- Output switchable

MAS RPSH

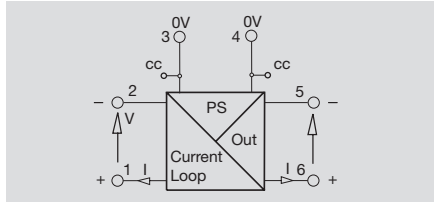
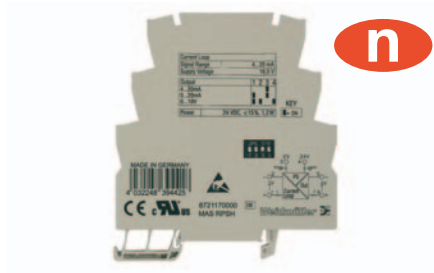

Technical data

Input

Input current	4...20 mA (sensor circuit)
Sensor	2-conductor
Feed voltage	16.5 V / constant for 3...22 mA

Output

Output current	0(4)...20 mA
Output voltage	0...10 V
Output signal limit	22...25 mA resp. 11...12.5 V
Load resistance voltage/Current	$\geq 10 \text{ k}\Omega / < = 600 \Omega$
Accuracy	$I_{out} < 0.1 \% / U_{out} < 0.2\%$
Offset current	$< 30 \mu\text{A}$
Temperature coefficient	$< 50 \text{ ppm/K}$
Residual ripple	$< 10 \text{ mVeff}$

General data

Supply voltage	24 Vdc +/- 15 %
Power consumption	approx. 1 W
Communication	according to HART Specification
Current-carrying cap. of cross-connect.	$\leq 20 \text{ A}$
Operation temperature	0 °C...+55 °C
Storage temperature	-25 °C...+85 °C
Approvals	CE / cURus

Insulation coordinates

Standards	EN 50178 (safe separation)
EMC standards	DIN EN 61326 class B
Rated voltage	600 V
Isolation voltage Input, output	2.5 kVac
Overtoltage category	II
Pollution severity	2

Dimensions

Clamping range (rating- / min. / max.)	mm ²
Length x width x height	mm

Screw connection

	1.50 / 0.50 / 2.50
	88.0 x 6.1 x 97.8

Information

Ordering data

Type of connection

Screw connection

Type	Qty.	Order No.
MAS RPSH	1	8721170000

Information

Accessories

Information

Voltage supply 24V and 0V with ZQV 4N/x cross-connection

Articles with coloured order number are kept permanently in stock at the central warehouse in Germany. Delivery times see page X.2

PT100 / RTD - signal isolator/converter

PT100, 2-Conductor converter

- 2-conductor technology
- Adjustable temperature range
– 200 °C ... + 800 °C
- Power supply can be cross connected via plug-in jumper

PT100/2 0(4)...20mA



PT100/2 0...10V

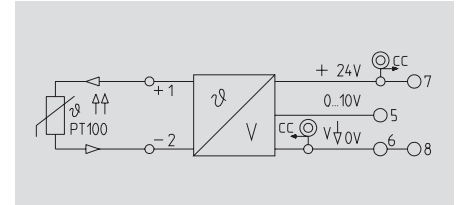
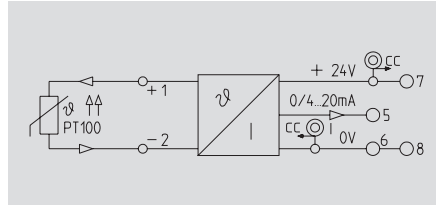
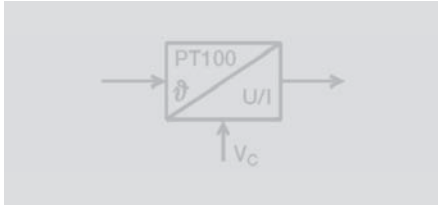

Technical data

Input

Sensor
Feed current

Output

Output voltage/Output current
Load resistance voltage/Current
Accuracy

General data

Supply voltage/Current consumption
Operation temperature/Storage temperature
Approvals
Standards
EMC standards

Dimensions

Clamping range (rating- / min. / max.) mm²
Length x width x height mm

Information

PT100/2-conductor
1.45 mA

/0(4)...20 mA

/ \leq = 600 Ω

+/-0.5% of measuring range

24 Vdc +/- 20 %/ \leq 48 mA at I_{out} = 20 mA

0 °C...+55 °C/-20 °C...+85 °C

CSA / UL/UR / CE / ESD

EN 50178, EN 60751, IEC751

EN 50081, EN50082, EN55011

Screw connection

2.50 / 0.50 / 2.50 1.50 / 0.50 / 2.50

92.4 x 12.5 x 112.4 92.4 x 12.5 x 112.4

T_u=23°C, single module

PT100/2-conductor
1.45 mA

0...10 V/

\geq 1 k Ω /

+/-0.5% of measuring range

24 Vdc +/- 20 %/ \leq 38 mA at I_{out} = 20 mA

0 °C...+55 °C/-20 °C...+85 °C

CSA / UL/UR / CE / ESD

EN 50178, EN 60751, IEC751

EN 50081, EN50082, EN55011

Screw connection

2.50 / 0.50 / 2.50 1.50 / 0.50 / 2.50

92.4 x 12.5 x 112.4 92.4 x 12.5 x 112.4

T_u=23°C, single module

Ordering data

Temperature input range	Type of connection
Adjustable -200...+800 °C	Screw connection
Adjustable -200...+800 °C	Tension clamp c.
Special adjustment	Screw connection
Special adjustment	Tension clamp connection
0...100 °C	Screw connection
0...100 °C	Tension clamp connection
0...100 °C	Screw connection
0...100 °C	Tension clamp connection

Information

Type	Qty.	Order No.
WTS4 PT100/2 C 0/4-20mA	1	8432210000
WTS4 PT100/2 C 0/4-20mA	1	8432220000
WTS4 PT100/2 C 0/4-20mA variable	1	8432219999
WTS4 PT100/2 C 0/4-20mA variable	1	8432229999
WTS4 PT100/2 C 0-20mA 0...100C	1	8432210001
WTS4 PT100/2 C 0-20mA 0...100C	1	8432220001
WTS4 PT100/2 C 4-20mA 0...100C	1	8432210011
WTS4 PT100/2 C 4-20mA 0...100C	1	8432220011

Specify temperature range by special calibrations.

Type	Qty.	Order No.
WTS4 PT100/2 V 0-10V	1	8432180000
WTS4 PT100/2 V 0-10V	1	8432190000
WTS4 PT100/2 V 0-10V variable	1	8432189999
WTS4 PT100/2 Vn 0-10V variable	1	8432199999
WTS4 PT100/2 V 0-10V 0...100C	1	8432180001
WTS4 PT100/2 V 0-10V 0...100C	1	8432190001

Specify temperature range by special calibrations.

Application

Example for Zero and Span

Temperature adjustment:

T_{min} -10 °C
Span 75...110 °C

Span 95 °C
Adjustment of Span + 25 %

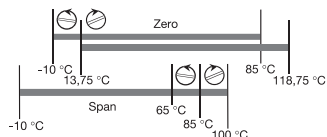

Temperature coefficient

Measurement range \geq 200 K \leq 200 ppm / °C (typ. 80 ppm / °C)
100K \leq Measurement range $<$ 200 K \leq 225 ppm / °C (typ. 90 ppm / °C)
40K \leq Measurement range $<$ 100 K \leq 450 ppm / °C (typ. 180 ppm / °C)

Aids

- Voltage supply 24 Vdc, 50 mA
- Simulator for PT 100 or precision-resistance-decade
- Ampere-/voltmeter which can be calibrated to an accuracy of $>$ 0.1% of the end value.

Switch position/setting options

	1	2	3	Span	4	5	6
0 °C	■	■	■	40 ... 50 °C	■	■	■
-10 °C	■	■	■	50 ... 75 °C	■	■	■
-20 °C	■	■	■	75 ... 110 °C	■	■	■
-40 °C	■	■	■	110 ... 165 °C	■	■	■
-60 °C	■	■	■	165 ... 245 °C	■	■	■
-80 °C	■	■	■	245 ... 360 °C	■	■	■
-100 °C	■	■	■	360 ... 540 °C	■	■	■
-200 °C	■	■	■	540 ... 800 °C	■	■	■

Output 1)

Range	7	PT 100	8	9	10
0 ... 20 mA	■	2 - wire	■	■	■
4 ... 20 mA	■	3 - wire	■	■	■
		4 - wire	■	■	■

1) only modules with current output

■ = on
□ = off

PT100 / RTD - signal isolator/converter

PT100, 3-Conductor converter

- 3-conductor technology
- Adjustable temperature range
- 200 °C ...+ 800 °C
- Power supply can be cross connected via plug-in jumper

PT100/3 0(4)...20mA

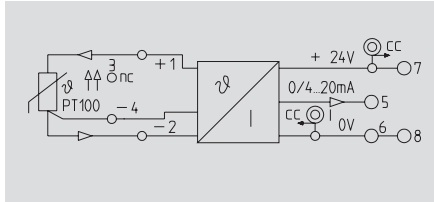
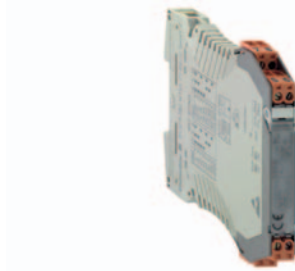

PT100/3 0...10V

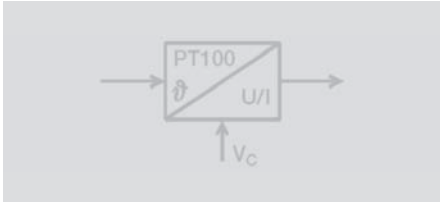
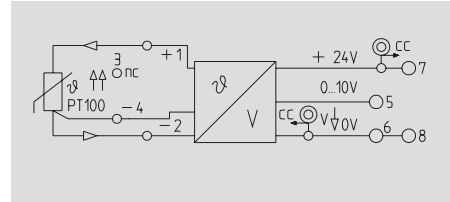

Technical data

Input	
Sensor	PT100/3-conductor
Feed current	1.45 mA
Output	
Output voltage/Output current	/0(4)...20 mA
Load resistance voltage/Current	/ $\lt = 600 \Omega$
Accuracy	+/-0.5% of measuring range
General data	
Supply voltage/Current consumption	24 Vdc +/- 20 %/ $\lt 48$ mA at Iout = 20 mA
Operation temperature/Storage temperature	0 °C...+55 °C/-20 °C...+85 °C
Approvals	CSA / UL/UR / CE / ESD
Standards	EN 50178, EN 60751, IEC751
EMC standards	EN 50081, EN50082, EN55011
Dimensions	
Clamping range (rating- / min. / max.)	mm ²
Length x width x height	mm
Information	
Tu=23°C, single module	

Input	
Sensor	PT100/3-conductor
Feed current	1.45 mA
Output	
Output voltage/Output current	0...10 V/
Load resistance voltage/Current	$\gt = 1 \text{ k}\Omega$
Accuracy	+/-0.5% of measuring range
General data	
Supply voltage/Current consumption	24 Vdc +/- 20 %/ $\lt 38$ mA at Iout = 20 mA
Operation temperature/Storage temperature	0 °C...+55 °C/-20 °C...+85 °C
Approvals	CSA / UL/UR / CE / ESD
Standards	EN 50178, EN 60751, IEC751
EMC standards	EN 50081, EN50082, EN55011
Dimensions	
Clamping range (rating- / min. / max.)	mm ²
Length x width x height	mm
Information	
Tu=23°C, single module	

Screw connection		Tension clamp c.	
2.50 / 0.50 / 2.50	1.50 / 0.50 / 2.50	2.50 / 0.50 / 2.50	1.50 / 0.50 / 2.50
92.4 x 12.5 x 112.4	92.4 x 12.5 x 112.4	92.4 x 12.5 x 112.4	92.4 x 12.5 x 112.4
Information			
Tu=23°C, single module			

Ordering data

Temperature input range	Type of connection
Adjustable -200...+800 °C	Screw connection
Adjustable -200...+800 °C	Tension clamp c.
Special adjustment	Screw connection
Special adjustment	Tension clamp connection
0...100 °C	Screw connection
0...100 °C	Tension clamp connection
0...100 °C	Screw connection
0...100 °C	Tension clamp connection
Information	
Specify temperature range by special calibrations.	

Type	Qty.	Order No.
WTS4 PT100/3 C 0/4-20mA	1	8432150000
WTS4 PT100/3 C 0/4-20mA	1	8432160000
WTS4 PT100/3 C 0/4-20mA variable	1	8432159999
WTS4 PT100/3 C 0/4-20mA variable	1	8432169999
WTS4 PT100/3 C 0-20mA 0...100C	1	8432150001
WTS4 PT100/3 C 0-20mA 0...100C	1	8432160001
WTS4 PT100/3 C 4-20mA 0...100C	1	8432150011
WTS4 PT100/3 C 4-20mA 0...100C	1	8432160011
Information		
Specify temperature range by special calibrations.		

Type	Qty.	Order No.
WTS4 PT100/3 V 0-10V	1	8432090000
WTS4 PT100/3 V 0-10V	1	8432130000
WTS4 PT100/3 V 0-10V variabel	1	8432099999
WTS4 PT100/3 V 0-10V variabel	1	8432139999
WTS4 PT100/3 V 0-10V 0...100C	1	8432090001
WTS4 PT100/3 V 0-10V 0...100C	1	8432130001
Information		
Specify temperature range by special calibrations.		

Application

Example for Zero and Span

Temperature adjustment:

Tmin	-10 °C
Span	75...110 °C
Span	95 °C
Adjustment of Span	+ 25 %

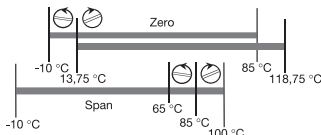

Temperature coefficient

Measurement range ≥ 200 K	≤ 200 ppm / °C (typ. 80 ppm / °C)
100K \leq Measurement range $\lt 200$ K ≤ 250 K	≤ 250 ppm / °C (typ. 100 ppm / °C)
40K \leq Measurement range $\lt 100$ K ≤ 500 K	≤ 500 ppm / °C (typ. 200 ppm / °C)

Aids

- Voltage supply 24 Vdc, 50 mA
- Simulator for PT 100 or precision-resistance-decade
- Ampere-/voltmeter which can be calibrated to an accuracy of $\gt 0.1\%$ of the end value.

Switch position/setting options

Tmin	1	2	3	Span	4	5	6
0 °C	■	■	■	40 ... 50 °C	■	■	■
-10 °C	■	■	■	50 ... 75 °C	■	■	■
-20 °C	■	■	■	75 ... 110 °C	■	■	■
-40 °C	■	■	■	110 ... 165 °C	■	■	■
-60 °C	■	■	■	165 ... 245 °C	■	■	■
-80 °C	■	■	■	245 ... 360 °C	■	■	■
-100 °C	■	■	■	360 ... 540 °C	■	■	■
-200 °C	■	■	■	540 ... 800 °C	■	■	■

Output 1)	7
Range	
0 ... 20 mA	■
4 ... 20 mA	■

1) only modules with current output

■ = on
□ = off

PT100 / RTD - signal isolator/converter

PT100, 4-Conductor converter

- 4-conductor technology
- Adjustable temperature range
- 200 °C ... + 800 °C
- Power supply can be cross connected via plug-in jumper

PT100/4 0(4)...20mA

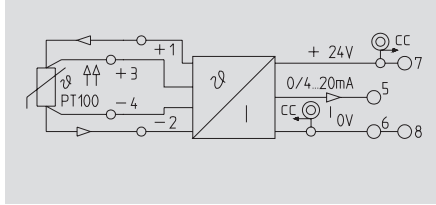

PT100/4 0...10V

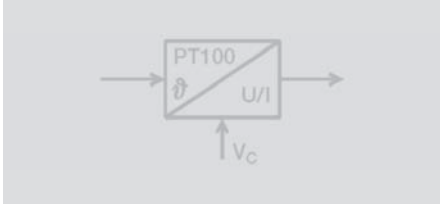
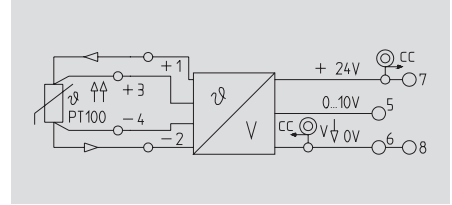

Technical data

Input

Sensor
Feed current

Output

Output voltage/Output current
Load resistance voltage/Current
Accuracy

General data

Supply voltage/Current consumption
Operation temperature/Storage temperature
Approvals
Standards
EMC standards

Dimensions

Clamping range (rating- / min. / max.) mm²
Length x width x height mm

Information

PT100/4-conductor
1.45 mA
/0(4)...20 mA
/ R_L = 600 Ω
100K <= MR < 600K: 0.1%; MR >= 600K: 0.2% of MR
24 Vdc +/- 20 % / I_{out} = 20 mA
0 °C...+55 °C / -20 °C...+85 °C
CSA / UL/UR / CE / ESD
EN 50178, EN 60751, IEC751
EN 50081, EN50082, EN55011

Screw connection 2.50 / 0.50 / 2.50
Tension clamp c. 1.50 / 0.50 / 2.50
92.4 x 12.5 x 112.4

Tu=23°C, single module

PT100/4-conductor
1.45 mA
0...10 V/
>= 1 k Ω /
100K <= MR < 600K: 0.1%; MR >= 600K: 0.2% of MR
24 Vdc +/- 20 % / I_{out} = 20 mA
0 °C...+55 °C / -20 °C...+85 °C
CSA / UL/UR / CE / ESD
EN 50178, EN 60751, IEC751
EN 50081, EN50082, EN55011

Screw connection 2.50 / 0.50 / 2.50
Tension clamp c. 1.50 / 0.50 / 2.50
92.4 x 12.5 x 112.4

Tu=23°C, single module

Ordering data

Temperature input range	Type of connection
Adjustable -200...+800 °C	Screw connection
Adjustable -200...+800 °C	Tension clamp c.
Special adjustment	Screw connection
Special adjustment	Tension clamp connection
0...100 °C	Screw connection
0...100 °C	Tension clamp connection
0...100 °C	Screw connection
0...100 °C	Tension clamp connection

Information

Type	Qty.	Order No.
WTS4 PT100/4 C 0/4-20mA	1	8432270000
WTS4 PT100/4 C 0/4-20mA	1	8432280000
WTS4 PT100/4 C 0/4-20mA variable	1	8432279999
WTS4 PT100/4 C 0/4-20mA variable	1	8432289999
WTS4 PT100/4 C 0...20mA 0...100C	1	8432270001
WTS4 PT100/4 C 0...20mA 0...100C	1	8432280001
WTS4 PT100/4 C 4-20mA 0...100C	1	8432270011
WTS4 PT100/4 C 4-20mA 0...100C	1	8432280011

Specify temperature range by special calibrations

Type	Qty.	Order No.
WTS4 PT100/4 V 0-10V	1	8432240000
WTS4 PT100/4 V 0-10V	1	8432250000
WTS4 PT100/4 V 0-10V variabel	1	8432249999
WTS4 PT100/4 V 0-10V variabel	1	8432259999
WTS4 PT100/4 V 0-10V 0...100C	1	8432240001
WTS4 PT100/4 V 0-10V 0...100C	1	8432250001

Specify temperature range by special calibrations

Application

Example for Zero and Span

Temperature adjustment:

Tmin -10 °C
Span 75...110 °C

Span 95 °C
Adjustment of Span + 25 %

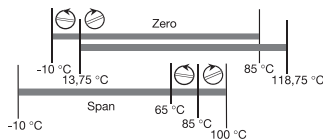

Temperature coefficient

Measurement range ≥ 200 K ≤ 200 ppm / °C (typ. 80 ppm / °C)
100K \leq Measurement range < 200 K ≤ 225 ppm / °C (typ. 90 ppm / °C)
40K \leq Measurement range < 100 K ≤ 450 ppm / °C (typ. 180 ppm / °C)

Aids

- Voltage supply 24 Vdc, 50 mA
- Simulator for PT 100 or precision-resistance-decade
- Ampere-/voltmeter which can be calibrated to an accuracy of >0.1% of the end value.

Switch position/setting options

	1	2	3	Span	4	5	6
0 °C	■	■	■	40 ... 50 °C	■	■	■
-10 °C	■	■	■	50 ... 75 °C	■	■	■
-20 °C	■	■	■	75 ... 110 °C	■	■	■
-40 °C	■	■	■	110 ... 165 °C	■	■	■
-60 °C	■	■	■	165 ... 245 °C	■	■	■
-80 °C	■	■	■	245 ... 360 °C	■	■	■
-100 °C	■	■	■	360 ... 540 °C	■	■	■
-200 °C	■	■	■	540 ... 800 °C	■	■	■

Output 1)		PT 100			
Range	7	8	9	10	
0 ... 20 mA	■	2 - wire	■	■	■
4 ... 20 mA	■	3 - wire	■	■	■
		4 - wire	■	■	■

1) only modules with current output ■ = on □ = off

PT100 / RTD - signal isolator/converter

PT100, 2-/3-Conductor disconnector converter

- For 2- or 3-conductor PT100 sensors
- Loop-fed output current
- High accuracy and linearity

MCZ PT100/3 CLP

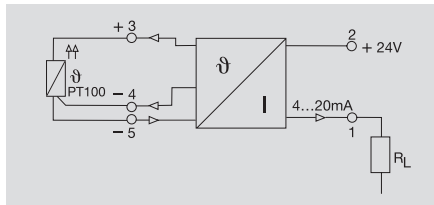
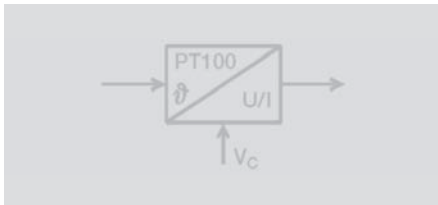
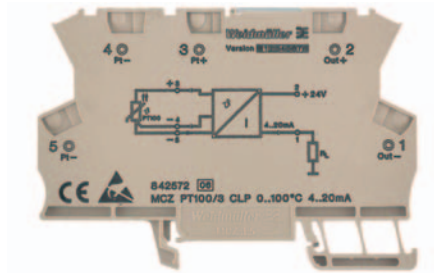

Technical data

Input	
Sensor	PT100/2-/3-conductor
Feed current	0.8 mA
Output	
Output current	4...20 mA (current loop)
Load resistance voltage/Current	/< = 600 Ω
Accuracy/Influence of cable resistance	typical 0.2%, max. 0.5% of FSR/max. 0.6 K/Ω
Response time	10 ms
General data	
Operation temperature/Storage temperature	0 °C...+50 °C/-20 °C...+85 °C
Approvals	CSA;UL/UR;CE;ESD;
Standards	EN 50178, EN 60751, IEC751
EMC standards	EMVG, EN 50081-1, EN 50082-2
Dimensions	
Clamping range (rating- / min. / max.)	mm²
Length x width x height	mm
Information	
	Tu=23°C, single module
Tension clamp c.	
	1.50 / 0.50 / 1.50
	91.0 x 6.0 x 63.2

Ordering data

Temperature input range	Type of connection	Type	Qty.	Order No.
0...100 °C	Tension clamp c.	MCZ PT100/3 CLP 0...100C	10	8425720000
0...120 °C	Tension clamp c.	MCZ PT100/3 CLP 0...120C	10	8483680000
0...150 °C	Tension clamp c.	MCZ PT100/3 CLP 0...150C	10	8604420000
0...200 °C	Tension clamp c.	MCZ PT100/3 CLP 0...200C	10	8473010000
0...300 °C	Tension clamp c.	MCZ PT100/3 CLP 0...300C	10	8473020000
-50...+150 °C	Tension clamp c.	MCZ PT100/3 CLP -50C...+150C	10	8473000000
-40...+100 °C	Tension clamp c.	MCZ PT100/3 CLP -40C...100C	10	8604430000
Information				

Application

PT100 / RTD - signal isolator/converter

PT100, 2-/3-Conductor disconnector converter

- 2-way isolation between input/output and power supply
- PT100 2-/ 3-conductor
- Output can be switched calibrated via DIP-switch

PT100 Output select

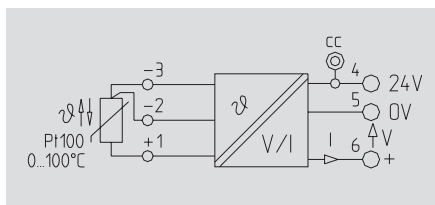
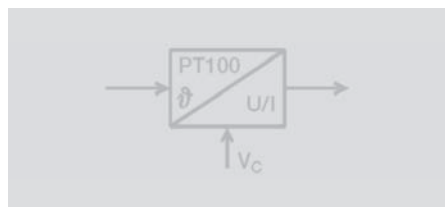
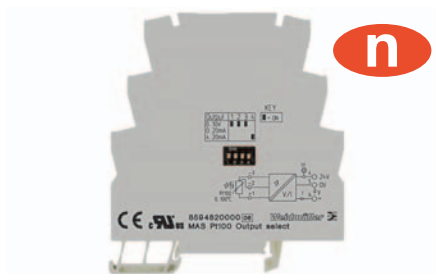

Technical data

Input

Sensor
Feed current
Temperature input range

Output

Output voltage/Output current
Load resistance voltage/Current
Accuracy
Temperature coefficient
Step response time

General data

Supply voltage
Power consumption
Current-carrying cap. of cross-connect.
Operation temperature
Storage temperature
Default settings
Approvals

Insulation coordinates

Standards
EMC standards
Rated voltage
Impulse withstand voltage
Isolation voltage Input, output/
Overvoltage category
Pollution severity
Clearance & creepage path

PT100/2-/3-conductor
0.8 mA
0...100 °C

0...10V / 0...5V/0(4)...20 mA
>= 10 kΩ / < = 600 Ω
< 0.5 % out of measuring range
<= 250 ppm/K of final value
< 0.7 s

24 Vdc +/- 10 %
approx. 0.6 W
<= 20 A
0 °C...+55 °C
-20 °C...+85 °C
0...20mA
CE / ESD / cURus

EN 50178, EN 60751, IEC751
EN 50081, EN 50082, EN 55011, EN 61000-6-2, EN 61326
100 V
1.5 kV
500 Veff/
III
2
>= 1.5mm

Output	Switch			
	1	2	3	4
) ... 10 V	■	■	■	□
) ... 20 mA	□	□	□	□
† ... 20 mA	□	□	□	■
) ... 5 V	■	■	■	■

■ = ein
□ = aus

Connection

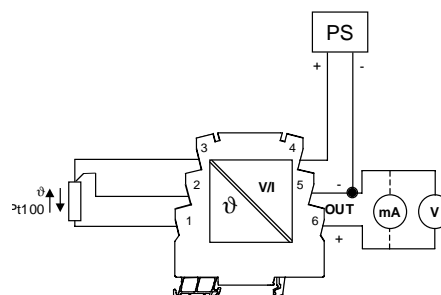

Dimensions

Clamping range (rating- / min. / max.) mm²
Length x width x height mm

Information

Screw connection

2.50 / 0.50 / 2.50
88.0 x 6.1 x 97.8

Tension clamp c.

1.50 / 0.50 / 2.50
92.0 x 6.1 x 97.8

Tu=23°C, single module

Ordering data

Type of connection

Screw connection
Tension clamp c.

Type	Qty.	Order No.
MAS PT100 0...100C	1	8594820000
MAZ PT100 0...100C	1	8594850000

Information

Accessories

Information

Information accessoriesVoltage supply 24V and 0V with ZQV 4N/x cross-connection

PT100 / RTD - signal isolator/converter

RTD, signal disconnecter converter

- Universal adjustable via DIP-switch
- 3-way isolation
- Linearization
- Power supply can be cross connected via plug-in jumper

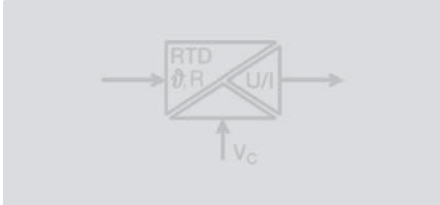

PRO RTD

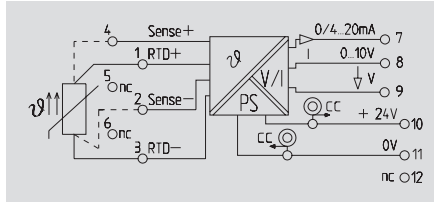

PRO RTD 1000

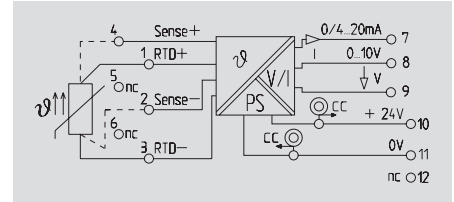

Technical data

Input

Sensor
Temperature input range

Output

Output current/Output voltage
Offset current/Offset voltage
Load resistance voltage/Current
Step response time
Line resistance in measuring circuit
Influence of cable resistance
Wire break detection
Fine adjustment
Status indicator

General data

Supply voltage
Power consumption
Current-carrying cap. of cross-connect.
Operation temperature
Storage temperature
Default settings
Approvals

Insulation coordinates

Standards
EMC standards
Rated voltage
Impulse withstand voltage
Isolation voltage Input, output
Overvoltage category
Pollution severity
Clearance & creepage path

Dimensions

Clamping range (rating- / min. / max.) mm²
Length x width x height mm

Information

Ordering data

Type of connection

Screw connection
Tension clamp c.

Information

Accessories

Information

PT100/2-/3-/4-cond.; Ni100/2-/3-/4-cond.; potentiometer:
min. 0...100Ω, max. 0...100kΩ; resistance: 0...450Ω
configurable

0(4)...20 mA/0...10 V
max. 100 μA/max. 0.05 V
≥ 1 kΩ/≤ 600 Ω
fast: 1.2 s/ slow: 2.2 s

50 Ω
max. + 0.25°C at 50 Ω cond. resistance
LED flashes (output value > 20mA, > 10V)
≥ ±0.5%, Version 1: ≥ 12.5% / Poti: 12.5%...25%
active: LED on/cond. broken: LED flashing/Error: LED off

24 Vdc +/- 25 %
830...880...980mW at Iout=20mA

≤ 2 A
0 °C...+55 °C
-20 °C...+85 °C

PT100/3-cond./ 0...100°C / 4...20mA / man. adjustment: off /
slow step response
GL / CE / cURus

EN 50178, EN 60751, IEC 751, DIN 43760
EN 50081, EN50082, EN55011

300 V
4 kV
2 kVeff / 5s

III
2
≥ 3 mm

Screw connection

2.50 / 0.50 / 2.50
92.4 x 17.5 x 112.4

Tension clamp c.

1.50 / 0.50 / 2.50
92.4 x 17.5 x 112.4

Tu=23°C, single module

PT1000/2-/3-/4-cond.; Ni1000/2-/3-/4-cond.; potentiometer:
min. 0-1kΩ, max. 0-100kΩ; resistance: 0-4,5kΩ
configurable

0(4)...20 mA/0...10 V
max. 100 μA/max. 0.05 V
≥ 1 kΩ/≤ 600 Ω
fast/slow: 2-/3-/4-cond.: 1.2s/2.3s; Poti: 0.5s/1.2s

50 Ω for 3- and 4-conductor
max. + 0.25°C at 50 Ω cond. resistance
LED flashes (output value > 20mA, > 10V)
≥ ±0.5%; Poti: ±0.5% ... ±0.25%
active: LED on/cond. broken: LED flashing/Error: LED off

24 Vdc +/- 25 %
830...880...980mW at Iout=20mA

≤ 2 A
0 °C...+55 °C
-20 °C...+85 °C

PT1000/3-cond./ 0...100°C / 4...20mA / man. adjustment: off /
slow step response

EN 50178, EN 60751, IEC 751, DIN 43760
EN 50081, EN50082, EN55011

300 V
4 kV
2 kVeff / 5s

III
2
≥ 3 mm

Screw connection

2.50 / 0.50 / 2.50
92.4 x 17.5 x 112.4

Tension clamp c.

1.50 / 0.50 / 2.50
92.4 x 17.5 x 112.4

Tu=23°C, single module

Type

WAS5 PRO RTD 1000 Qty. 1 Order No. 8679490000
WAZ5 PRO RTD 1000 Qty. 1 Order No. on demand

Information

Voltage supply 24V and 0V with ZQV 2.5N/2
cross-connection

DC/DC signal converter – configurable

WAVEANALOG PRO RTD

WAVEANALOG PRO RTD 1000

Switch positions/possible settings

Input	Switch 1		
	1	2	3
PT100 2-conductor	<input checked="" type="checkbox"/>	<input checked="" type="checkbox"/>	<input checked="" type="checkbox"/>
PT100 3-conductor	<input type="checkbox"/>	<input checked="" type="checkbox"/>	<input checked="" type="checkbox"/>
PT100 4-conductor	<input checked="" type="checkbox"/>	<input type="checkbox"/>	<input checked="" type="checkbox"/>
R 2-conductor	<input type="checkbox"/>	<input type="checkbox"/>	<input checked="" type="checkbox"/>
Ni100 2-conductor	<input checked="" type="checkbox"/>	<input checked="" type="checkbox"/>	<input type="checkbox"/>
Ni100 3-conductor	<input type="checkbox"/>	<input checked="" type="checkbox"/>	<input type="checkbox"/>
Ni100 4-conductor	<input checked="" type="checkbox"/>	<input type="checkbox"/>	<input type="checkbox"/>
Potentiometer	<input type="checkbox"/>	<input type="checkbox"/>	<input type="checkbox"/>

= on
 = off

Switch positions/possible settings

Input	Switch 1		
	1	2	3
PT1000 2-conductor	<input checked="" type="checkbox"/>	<input checked="" type="checkbox"/>	<input checked="" type="checkbox"/>
PT1000 3-conductor	<input type="checkbox"/>	<input checked="" type="checkbox"/>	<input checked="" type="checkbox"/>
PT1000 4-conductor	<input checked="" type="checkbox"/>	<input type="checkbox"/>	<input checked="" type="checkbox"/>
R 2-conductor	<input type="checkbox"/>	<input type="checkbox"/>	<input checked="" type="checkbox"/>
Ni1000 2-conductor	<input checked="" type="checkbox"/>	<input checked="" type="checkbox"/>	<input type="checkbox"/>
Ni1000 3-conductor	<input type="checkbox"/>	<input checked="" type="checkbox"/>	<input type="checkbox"/>
Ni1000 4-conductor	<input checked="" type="checkbox"/>	<input type="checkbox"/>	<input type="checkbox"/>
Potentiometer	<input type="checkbox"/>	<input type="checkbox"/>	<input type="checkbox"/>

= on
 = off

Output	Switch 2		Switching on the manual adjustment	
	6	7	manual adjustment	S.1
0...10V	<input checked="" type="checkbox"/>	<input type="checkbox"/>		
0...20mA	<input type="checkbox"/>	<input type="checkbox"/>	off	<input type="checkbox"/>
4...20mA	<input type="checkbox"/>	<input checked="" type="checkbox"/>	on	<input checked="" type="checkbox"/>

step response	S.2
	step response
slow	<input checked="" type="checkbox"/>
fast	<input type="checkbox"/>

Selection of minimum input size						
θ _{min}	R _{min}	Poti _{min}	Switch 1			
			4	5	6	7
0°C	0 Ω	0%	<input checked="" type="checkbox"/>	<input checked="" type="checkbox"/>	<input checked="" type="checkbox"/>	<input checked="" type="checkbox"/>
-10°C	10 Ω	10%	<input checked="" type="checkbox"/>	<input checked="" type="checkbox"/>	<input checked="" type="checkbox"/>	<input type="checkbox"/>
-20°C	20 Ω	20%	<input checked="" type="checkbox"/>	<input checked="" type="checkbox"/>	<input type="checkbox"/>	<input checked="" type="checkbox"/>
-25°C	20 Ω	25%	<input checked="" type="checkbox"/>	<input type="checkbox"/>	<input type="checkbox"/>	<input type="checkbox"/>
-30°C	30 Ω	30%	<input checked="" type="checkbox"/>	<input type="checkbox"/>	<input type="checkbox"/>	<input type="checkbox"/>
-40°C	40 Ω	40%	<input checked="" type="checkbox"/>	<input type="checkbox"/>	<input checked="" type="checkbox"/>	<input type="checkbox"/>
-50°C	50 Ω	50%	<input checked="" type="checkbox"/>	<input type="checkbox"/>	<input type="checkbox"/>	<input checked="" type="checkbox"/>
-60°C	60 Ω	60%	<input checked="" type="checkbox"/>	<input type="checkbox"/>	<input type="checkbox"/>	<input type="checkbox"/>
-70°C	70 Ω	70%	<input type="checkbox"/>	<input type="checkbox"/>	<input type="checkbox"/>	<input checked="" type="checkbox"/>
-80°C	80 Ω	80%	<input type="checkbox"/>	<input checked="" type="checkbox"/>	<input checked="" type="checkbox"/>	<input type="checkbox"/>
-90°C	90 Ω		<input type="checkbox"/>	<input checked="" type="checkbox"/>	<input type="checkbox"/>	<input checked="" type="checkbox"/>
-100°C	100 Ω		<input type="checkbox"/>	<input checked="" type="checkbox"/>	<input type="checkbox"/>	<input type="checkbox"/>
-150°C	150 Ω		<input type="checkbox"/>	<input type="checkbox"/>	<input checked="" type="checkbox"/>	<input checked="" type="checkbox"/>
-200°C	200 Ω		<input type="checkbox"/>	<input type="checkbox"/>	<input checked="" type="checkbox"/>	<input type="checkbox"/>
Special range			<input type="checkbox"/>	<input type="checkbox"/>	<input type="checkbox"/>	<input checked="" type="checkbox"/>

Selection of minimum input size						
θ _{min}	R _{min}	Poti _{min}	Switch 1			
			4	5	6	7
0°C	0 Ω	0%	<input checked="" type="checkbox"/>	<input checked="" type="checkbox"/>	<input checked="" type="checkbox"/>	<input checked="" type="checkbox"/>
-10°C	100 Ω	10%	<input checked="" type="checkbox"/>	<input checked="" type="checkbox"/>	<input checked="" type="checkbox"/>	<input type="checkbox"/>
-20°C	200 Ω	20%	<input checked="" type="checkbox"/>	<input checked="" type="checkbox"/>	<input type="checkbox"/>	<input checked="" type="checkbox"/>
-25°C	200 Ω	25%	<input checked="" type="checkbox"/>	<input type="checkbox"/>	<input type="checkbox"/>	<input type="checkbox"/>
-30°C	300 Ω	30%	<input checked="" type="checkbox"/>	<input type="checkbox"/>	<input type="checkbox"/>	<input type="checkbox"/>
-40°C	400 Ω	40%	<input checked="" type="checkbox"/>	<input type="checkbox"/>	<input checked="" type="checkbox"/>	<input type="checkbox"/>
-50°C	500 Ω	50%	<input checked="" type="checkbox"/>	<input type="checkbox"/>	<input type="checkbox"/>	<input checked="" type="checkbox"/>
-60°C	600 Ω	60%	<input checked="" type="checkbox"/>	<input type="checkbox"/>	<input type="checkbox"/>	<input type="checkbox"/>
-70°C	700 Ω	70%	<input type="checkbox"/>	<input type="checkbox"/>	<input type="checkbox"/>	<input checked="" type="checkbox"/>
-80°C	800 Ω	80%	<input type="checkbox"/>	<input checked="" type="checkbox"/>	<input checked="" type="checkbox"/>	<input type="checkbox"/>
-90°C	900 Ω		<input type="checkbox"/>	<input checked="" type="checkbox"/>	<input type="checkbox"/>	<input checked="" type="checkbox"/>
-100°C	1000 Ω		<input type="checkbox"/>	<input checked="" type="checkbox"/>	<input type="checkbox"/>	<input type="checkbox"/>
-150°C	1500 Ω		<input type="checkbox"/>	<input type="checkbox"/>	<input checked="" type="checkbox"/>	<input checked="" type="checkbox"/>
-200°C	2000 Ω		<input type="checkbox"/>	<input type="checkbox"/>	<input checked="" type="checkbox"/>	<input type="checkbox"/>
Special range			<input type="checkbox"/>	<input type="checkbox"/>	<input type="checkbox"/>	<input checked="" type="checkbox"/>

Accuracy, slow/fast step response
PT 100, Ni100: 0.3% of measuring range 0.8%
Measuring range:
Potentiometer: 0.2% of final value / 0.3%
Resistance: 0.2% of final value / 0.3%

Temperature coefficient
Measuring range ≥ 200 K ≤ 200 ppm / °C
100 K ≤ Measuring range < 200 K ≤ 250 ppm / °C
40 K ≤ Measuring range < 100 K ≤ 400 ppm / °C

Choice of measuring range						
T	R	Potentiometer	Switch 2			
			1	2	3	4
40K	20Ω	20%	<input checked="" type="checkbox"/>	<input checked="" type="checkbox"/>	<input checked="" type="checkbox"/>	<input checked="" type="checkbox"/>
50K	25Ω	25%	<input checked="" type="checkbox"/>	<input checked="" type="checkbox"/>	<input checked="" type="checkbox"/>	<input type="checkbox"/>
60K	30Ω	30%	<input checked="" type="checkbox"/>	<input checked="" type="checkbox"/>	<input type="checkbox"/>	<input type="checkbox"/>
70K	35Ω	35%	<input checked="" type="checkbox"/>	<input checked="" type="checkbox"/>	<input type="checkbox"/>	<input type="checkbox"/>
80K	40Ω	40%	<input checked="" type="checkbox"/>	<input checked="" type="checkbox"/>	<input type="checkbox"/>	<input checked="" type="checkbox"/>
90K	45Ω	45%	<input checked="" type="checkbox"/>	<input checked="" type="checkbox"/>	<input type="checkbox"/>	<input type="checkbox"/>
100K	50Ω	50%	<input checked="" type="checkbox"/>	<input type="checkbox"/>	<input type="checkbox"/>	<input type="checkbox"/>
110K	55Ω	55%	<input checked="" type="checkbox"/>	<input type="checkbox"/>	<input type="checkbox"/>	<input type="checkbox"/>
120K	60Ω	60%	<input checked="" type="checkbox"/>	<input type="checkbox"/>	<input checked="" type="checkbox"/>	<input checked="" type="checkbox"/>
125K	62.5Ω	62.5%	<input checked="" type="checkbox"/>	<input type="checkbox"/>	<input type="checkbox"/>	<input type="checkbox"/>
130K	65Ω	65%	<input checked="" type="checkbox"/>	<input type="checkbox"/>	<input type="checkbox"/>	<input type="checkbox"/>
140K	70Ω	70%	<input checked="" type="checkbox"/>	<input type="checkbox"/>	<input type="checkbox"/>	<input type="checkbox"/>
150K	75Ω	75%	<input checked="" type="checkbox"/>	<input type="checkbox"/>	<input type="checkbox"/>	<input checked="" type="checkbox"/>
160K	80Ω	80%	<input checked="" type="checkbox"/>	<input type="checkbox"/>	<input type="checkbox"/>	<input type="checkbox"/>
170K	85Ω	85%	<input checked="" type="checkbox"/>	<input type="checkbox"/>	<input type="checkbox"/>	<input type="checkbox"/>
180K	90Ω	90%	<input checked="" type="checkbox"/>	<input type="checkbox"/>	<input type="checkbox"/>	<input type="checkbox"/>
190K	95Ω	95%	<input type="checkbox"/>	<input checked="" type="checkbox"/>	<input checked="" type="checkbox"/>	<input checked="" type="checkbox"/>
200K	100Ω	100%	<input type="checkbox"/>	<input checked="" type="checkbox"/>	<input type="checkbox"/>	<input type="checkbox"/>
250K	125Ω	---	<input type="checkbox"/>	<input checked="" type="checkbox"/>	<input type="checkbox"/>	<input type="checkbox"/>
300K	150Ω	---	<input type="checkbox"/>	<input checked="" type="checkbox"/>	<input type="checkbox"/>	<input type="checkbox"/>
350K	175Ω	---	<input type="checkbox"/>	<input checked="" type="checkbox"/>	<input type="checkbox"/>	<input checked="" type="checkbox"/>
400K	200Ω	---	<input type="checkbox"/>	<input checked="" type="checkbox"/>	<input type="checkbox"/>	<input type="checkbox"/>
450K	225Ω	---	<input type="checkbox"/>	<input checked="" type="checkbox"/>	<input type="checkbox"/>	<input type="checkbox"/>
500K	250Ω	---	<input type="checkbox"/>	<input checked="" type="checkbox"/>	<input type="checkbox"/>	<input type="checkbox"/>
550K	275Ω	---	<input type="checkbox"/>	<input type="checkbox"/>	<input checked="" type="checkbox"/>	<input checked="" type="checkbox"/>
600K	300Ω	---	<input type="checkbox"/>	<input type="checkbox"/>	<input checked="" type="checkbox"/>	<input type="checkbox"/>
650K	325Ω	---	<input type="checkbox"/>	<input type="checkbox"/>	<input checked="" type="checkbox"/>	<input type="checkbox"/>
700K	350Ω	---	<input type="checkbox"/>	<input type="checkbox"/>	<input checked="" type="checkbox"/>	<input type="checkbox"/>
750K	375Ω	---	<input type="checkbox"/>	<input type="checkbox"/>	<input type="checkbox"/>	<input checked="" type="checkbox"/>
800K	400Ω	---	<input type="checkbox"/>	<input type="checkbox"/>	<input type="checkbox"/>	<input type="checkbox"/>
850K	425Ω	---	<input type="checkbox"/>	<input type="checkbox"/>	<input type="checkbox"/>	<input type="checkbox"/>
900K	450Ω	---	<input type="checkbox"/>	<input type="checkbox"/>	<input type="checkbox"/>	<input type="checkbox"/>

Choice of measuring range						
T	R	Potentiometer	Switch 2			
			1	2	3	4
40K	200Ω	20%	<input checked="" type="checkbox"/>	<input checked="" type="checkbox"/>	<input checked="" type="checkbox"/>	<input checked="" type="checkbox"/>
50K	250Ω	25%	<input checked="" type="checkbox"/>	<input checked="" type="checkbox"/>	<input checked="" type="checkbox"/>	<input type="checkbox"/>
60K	300Ω	30%	<input checked="" type="checkbox"/>	<input checked="" type="checkbox"/>	<input type="checkbox"/>	<input type="checkbox"/>
70K	350Ω	35%	<input checked="" type="checkbox"/>	<input checked="" type="checkbox"/>	<input type="checkbox"/>	<input type="checkbox"/>
80K	400Ω	40%	<input checked="" type="checkbox"/>	<input checked="" type="checkbox"/>	<input type="checkbox"/>	<input checked="" type="checkbox"/>
90K	450Ω	45%	<input checked="" type="checkbox"/>	<input checked="" type="checkbox"/>	<input type="checkbox"/>	<input type="checkbox"/>
100K	500Ω	50%	<input checked="" type="checkbox"/>	<input type="checkbox"/>	<input type="checkbox"/>	<input type="checkbox"/>
110K	550Ω	55%	<input checked="" type="checkbox"/>	<input type="checkbox"/>	<input type="checkbox"/>	<input type="checkbox"/>
120K	600Ω	60%	<input checked="" type="checkbox"/>	<input type="checkbox"/>	<input checked="" type="checkbox"/>	<input checked="" type="checkbox"/>
125K	625Ω	62.5%	<input checked="" type="checkbox"/>	<input type="checkbox"/>	<input type="checkbox"/>	<input type="checkbox"/>
130K	650Ω	65%	<input checked="" type="checkbox"/>	<input type="checkbox"/>	<input type="checkbox"/>	<input type="checkbox"/>
140K	700Ω	70%	<input checked="" type="checkbox"/>	<input type="checkbox"/>	<input type="checkbox"/>	<input type="checkbox"/>
150K	750Ω	75%	<input checked="" type="checkbox"/>	<input type="checkbox"/>	<input type="checkbox"/>	<input checked="" type="checkbox"/>
160K	800Ω	80%	<input checked="" type="checkbox"/>	<input type="checkbox"/>	<input type="checkbox"/>	<input type="checkbox"/>
170K	850Ω	85%	<input checked="" type="checkbox"/>	<input type="checkbox"/>	<input type="checkbox"/>	<input type="checkbox"/>
180K	900Ω	90%	<input checked="" type="checkbox"/>	<input type="checkbox"/>	<input type="checkbox"/>	<input type="checkbox"/>
190K	950Ω	95%	<input type="checkbox"/>	<input checked="" type="checkbox"/>	<input checked="" type="checkbox"/>	<input checked="" type="checkbox"/>
200K	1000Ω	100%	<input type="checkbox"/>	<input checked="" type="checkbox"/>	<input type="checkbox"/>	<input type="checkbox"/>
250K	1250Ω	---	<input type="checkbox"/>	<input checked="" type="checkbox"/>	<input type="checkbox"/>	<input type="checkbox"/>
300K	1500Ω	---	<input type="checkbox"/>	<input checked="" type="checkbox"/>	<input type="checkbox"/>	<input type="checkbox"/>
350K	1750Ω	---	<input type="checkbox"/>	<input checked="" type="checkbox"/>	<input type="checkbox"/>	<input checked="" type="checkbox"/>
400K	2000Ω	---	<input type="checkbox"/>	<input checked="" type="checkbox"/>	<input type="checkbox"/>	<input type="checkbox"/>
450K	2250Ω	---	<input type="checkbox"/>	<input checked="" type="checkbox"/>	<input type="checkbox"/>	<input type="checkbox"/>
500K	2500Ω	---	<input type="checkbox"/>	<input checked="" type="checkbox"/>	<input type="checkbox"/>	<input type="checkbox"/>
550K	2750Ω	---	<input type="checkbox"/>	<input type="checkbox"/>	<input checked="" type="checkbox"/>	<input checked="" type="checkbox"/>
600K	3000Ω	---	<input type="checkbox"/>	<input type="checkbox"/>	<input checked="" type="checkbox"/>	<input type="checkbox"/>
650K	3250Ω	---	<input type="checkbox"/>	<input type="checkbox"/>	<input checked="" type="checkbox"/>	<input type="checkbox"/>
700K	3500Ω	---	<input type="checkbox"/>	<input type="checkbox"/>	<input checked="" type="checkbox"/>	<input type="checkbox"/>
750K	3750Ω	---	<input type="checkbox"/>	<input type="checkbox"/>	<input type="checkbox"/>	<input checked="" type="checkbox"/>
800K	4000Ω	---	<input type="checkbox"/>	<input type="checkbox"/>	<input type="checkbox"/>	<input type="checkbox"/>
850K	4250Ω	---	<input type="checkbox"/>	<input type="checkbox"/>	<input type="checkbox"/>	<input type="checkbox"/>
900K	4500Ω	---	<input type="checkbox"/>	<input type="checkbox"/>	<input type="checkbox"/>	<input type="checkbox"/>

Examples for setting zero and range	
Temperature setting:	
Output	4...20 mA
DIP switch	-10 °C...+110 °C
Range	75...110 °C
Range	120 °C
Range adjustment	± 12,5 %

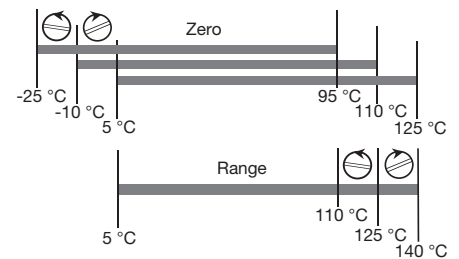

Setting aid WAVEtool
 The service tool is used for fast, uncomplicated configuration of WAVEANALOGUE PRO.
 Download from the internet:
<http://www.weidmueller.com>

PT100 / RTD - signal isolator/converter

RTD, signal disconnecter converter

- Universally adjustable via DIP-switch
- 3-way isolation
- Linearization
- Power supply can be cross connected via plug-in jumper

PRO RTD Cu

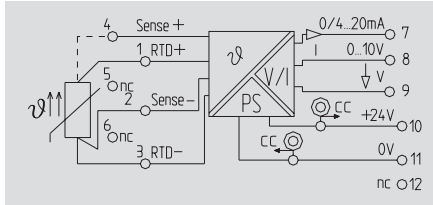
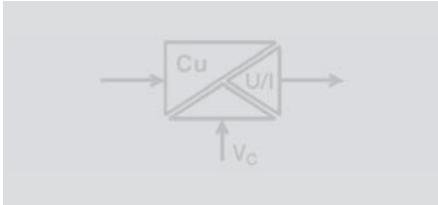

Selection of connection	Switch 1		Selection of sensor		
	1	2	Type	2	3
3-wire	■		Cu 10	■	■
4-wire	□		Cu 25	■	□
			Cu 50	□	■
			Cu 100	□	□

Selection of minimum input values	Switch 1			
	4	5	6	7
- 0 °C	■	■	■	■
-10 °C	■	■	■	□
-20 °C	■	■	□	■
-25 °C	■	■	□	□
-30 °C	■	□	■	■
-40 °C	■	□	■	□
-50 °C	■	□	□	■
-60 °C	■	□	□	□
-70 °C	□	■	■	■
-80 °C	□	■	■	□
-90 °C	□	■	□	■
-100 °C	□	■	□	□
-150 °C	□	□	■	■
-200 °C	□	□	■	□
special range	□	□	□	□

Selection of the measurement range	Switch 2				
	1	2	3	4	5
40 K	■	■	■	■	■
50 K	■	■	■	■	□
60 K	■	■	■	□	■
70 K	■	■	■	□	□
80 K	■	■	□	■	■
90 K	■	■	□	■	□
100 K	■	■	□	□	■
110 K	■	■	□	□	□
120 K	■	□	■	■	■
125 K	■	□	■	■	□
130 K	■	□	■	□	■
140 K	■	□	■	□	□
150 K	■	□	□	■	■
160 K	■	□	□	■	□
170 K	■	□	□	□	■
180 K	■	□	□	□	□
190 K	□	■	■	■	■
200 K	□	■	■	■	□
210 K	□	■	■	□	■
220 K	□	■	■	□	□
230 K	□	■	□	■	■
240 K	□	■	□	■	□
250 K	□	■	□	□	■
260 K	□	■	□	□	□
270 K	□	□	■	■	■
280 K	□	□	■	■	□
290 K	□	□	■	□	■
300 K	□	□	■	□	□
350 K	□	□	□	■	■
400 K	□	□	□	■	□
450 K	□	□	□	□	■
460 K	□	□	□	□	□

Selection of Output	Switch 2		Switching on the manual fine adjustment	
	6	7	man. adj.	Switch 1 8
0...10 V	■	□	off	□
0...20 mA	□	□	on	■
4...20 mA	□	■		

Selection of step set time	Schalter 2	
	Time of step response	8
slow	■	■ = on
fast	□	□ = off

Technical data

Input		
Sensor	Cu 10, Cu 25, Cu 50, Cu 100; 3-/4-cond.	
Temperature input range	adjustable -200...+260 °C	
Output		
Output current/Output voltage	0(4)...20 mA/0...10 V	
Offset current/Offset voltage	max. 100 µA/max. 0.05 V	
Load resistance voltage/Current	>= 1 kΩ/< = 600 Ω	
Step response time	fast: 1.2 s/ slow: 2.2 s	
Line resistance in measuring circuit	5 Ω Cu 10; 15 Ω Cu 25; 25 Ω Cu 50; 50 Ω Cu 100	
Influence of cable resistance	max. + 0.25°C at max. cond. resistance	
Wire break detection	LED flashes (output value > 20mA, > 10V)	
Fine adjustment	>= +/- 12.5 %	
Status indicator	active: LED on/cond. broken: LED flashing/Error: LED off	
General data		
Supply voltage	24 Vdc +/- 25 %	
Power consumption	880...980...1030mW at Iout=20mA	
Current-carrying cap. of cross-connect.	<= 2 A	
Operation temperature	0 °C...+55 °C	
Storage temperature	-20 °C...+85 °C	
Default settings	CU 10/3-cond.; 0...100°C; 4...20mA; no filter, manual adjustment off; slow step response	
Approvals	GL / CE / ESD / cURus	
Insulation coordinates		
Standards	EN 50178	
EMC standards	EN 50081, EN50082, EN55011	
Rated voltage	300 V	
Impulse withstand voltage	4 kV	
Isolation voltage Input, output	2 kVeff / 5s	
Overvoltage category	III	
Pollution severity	2	
Clearance & creepage path	>= 3 mm	
Dimensions		
Clamping range (rating- / min. / max.)	mm²	2.50 / 0.50 / 2.50
Length x width x height	mm	92.4 x 17.5 x 112.4
Information	Tu=23°C, single module	
Screw connection	Tension clamp c.	
Type	Qty.	Order No.
WAS5 PRO RTD Cu	1	8638950000
WAZ5 PRO RTD Cu	1	on demand
Information	Voltage supply 24V and 0V with ZQV 2.5N/2 cross-connection	

Ordering data

Type of connection	Type	Qty.	Order No.
Screw connection	WAS5 PRO RTD Cu	1	8638950000
Tension clamp c.	WAZ5 PRO RTD Cu	1	on demand

Information

Accessories

Information	Voltage supply 24V and 0V with ZQV 2.5N/2 cross-connection
--------------------	--

Articles with coloured order number are kept permanently in stock at the central warehouse in Germany. Delivery times see page X.2

Thermo element, signal isolator/converter

Thermo disconnecter converter Type: **Thermo Select**
K, J, T, E, N, R, S, B

- Calibration not necessary
- Cold-junction compensation
- Output signal selectable
- Power supply can be cross connected via plug-in jumper

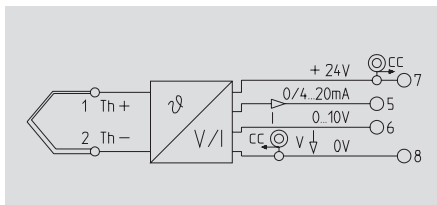
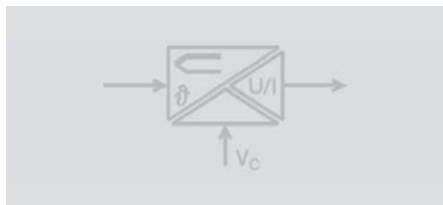

Technical data

Input	Sensor	thermo-elements (IEC 584) type: K,J,T,E,N,R,S,B
Temperature input range		-200...+1820 °C
Output	Output voltage/Output current	0...10 V/0(4)...20 mA
Load resistance voltage/Current		>= 1 kΩ / <= 600 Ω
Temperature coefficient		+/- (200 ppm from span + 0.075 K)/K
Step response time		with filter: 1.1 s; without filter: 6 s
Wire break detection		LED flashes (output value > 20mA, > 10V)
General data	Supply voltage	24 Vdc +/- 20 %
Current consumption		< 38 mA at Iout = 20 mA
Current-carrying cap. of cross-connect.		<= 2 A
Operation temperature		0 °C...+55 °C
Storage temperature		-20 °C...+85 °C
Approvals		CSA / UL/UR / CE / ESD
Insulation coordinates	Standards	EN 50178, EN 60584, IEC 584
EMC standards		EN 50081, EN50082, EN55011

Dimensions		
Clamping range (rating- / min. / max.)	mm²	
Length x width x height	mm	

Information	TU=23°C, single module
--------------------	------------------------

Ordering data

Type of connection	Screw connection
	Tension clamp c.

Information	
--------------------	--

Accessories

Information	Voltage supply 24V and 0V with ZQV 2.5N/2 cross-connection
--------------------	--

Screw connection	WTS4 THERMO	Qty. 1	Order No. 8432300000
Tension clamp c.	WTS4 THERMO	Qty. 1	Order No. 8432310000

Type	Qty.	Order No.
WTS4 THERMO	1	8432300000
WTS4 THERMO	1	8432310000

Information	Voltage supply 24V and 0V with ZQV 2.5N/2 cross-connection
--------------------	--

Switch position/setting options

SW 1				SW 2					
Type	1	2	3	Span	1	2	3	4	5
K	■	■	■	100 °C	■	■	■	■	■
J	□	■	■	150 °C	■	■	■	■	□
T	■	□	■	200 °C	■	■	■	■	■
E	□	□	■	250 °C	■	■	■	■	□
N	■	■	□	300 °C	■	■	■	■	■
R	□	■	□	350 °C	■	■	■	■	■
S	■	□	□	400 °C	■	■	■	■	■
B	□	□	□	450 °C	■	■	■	■	□
				500 °C	■	■	■	■	■
				550 °C	■	□	■	■	■
				600 °C	■	□	■	■	■
				650 °C	■	□	■	■	■
				700 °C	■	□	■	■	■
				750 °C	■	□	■	■	■
				800 °C	■	□	■	■	■
				850 °C	■	□	■	■	■
				900 °C	■	□	■	■	■
				950 °C	■	□	■	■	■
				1000 °C	■	□	■	■	■
				1050 °C	■	□	■	■	■
				1100 °C	■	□	■	■	■
				1150 °C	■	□	■	■	■
				1200 °C	■	□	■	■	■
				1250 °C	■	□	■	■	■
				1300 °C	■	□	■	■	■
				1350 °C	■	□	■	■	■
				1400 °C	■	□	■	■	■
				1450 °C	■	□	■	■	■
				1500 °C	■	□	■	■	■
				1600 °C	■	□	■	■	■
				1700 °C	■	□	■	■	■
				1800 °C	■	□	■	■	■

SW 1		
Tmin	4	5 6 7
0 °C	■	■
-10 °C	■	■
-20 °C	■	■
-30 °C	■	■
-40 °C	■	■
-50 °C	■	■
-100 °C	■	■
-150 °C	■	■
-200 °C	■	■
+50 °C	■	■
+100 °C	■	■
+150 °C	■	■
+200 °C	■	■
+250 °C	■	■
+500 °C	■	■

SW 2	
Output	6 7
0 - 10 V	■
0 - 20 mA	□
4 - 20 mA	■

Filter 8	
off	□
on	■

Temperature coefficient		
K	-200°C ...-150°C	± (6K + 0.1% of set range)
	-150°C ...1200°C	± (3K + 0.1% of set range)
	1200°C ...1372°C	± (4K + 0.1% of set range)
J	-200°C ...-150°C	± (4K + 0.1% of set range)
	-150°C ...1200°C	± (3K + 0.1% of set range)
T	-200°C ...-150°C	± (5K + 0.1% of set range)
	-150°C ...400°C	± (3K + 0.1% of set range)
E	-200°C ...-150°C	± (4K + 0.1% of set range)
	-150°C ...1000°C	± (3K + 0.1% of set range)
N	-200°C ...-150°C	± (6K + 0.1% of set range)
	-150°C ...1300°C	± (3K + 0.1% of set range)
R	-50°C ...200°C	± (10K + 0.1% of set range)
	200°C ...1760°C	± (6K + 0.1% of set range)
S	-50°C ...200°C	± (10K + 0.1% of set range)
	200°C ...1760°C	± (6K + 0.1% of set range)
B	50°C ...250°C	± (25K + 0.1% of set range)
	250°C ...500°C	± (10K + 0.1% of set range)
	500°C ...1820°C	± (6K + 0.1% of set range)

Thermo element, signal isolator/converter

Thermo disconnecter converter type: K

- 2-way isolation between input/output and voltage supply
- Cold-junction compensation
- Linearization
- Output can be switched calib. via DIP-switch

Thermo K Output Select

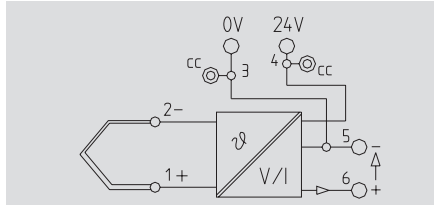
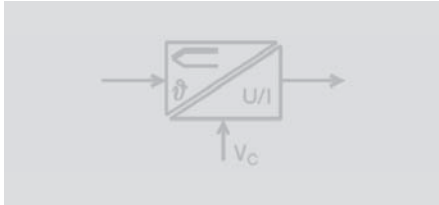
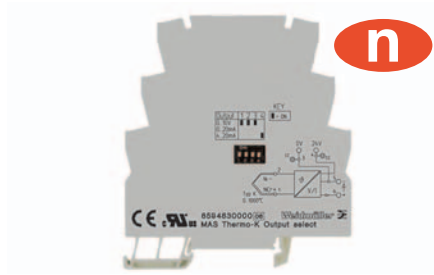

Output	Switch			
	1	2	3	4
0 ... 10 V	■	■	■	□
0 ... 20 mA	□	□	□	□
4 ... 20 mA	□	□	□	■
0 ... 5 V	■	■	■	■

■ = on
□ = off

Connection

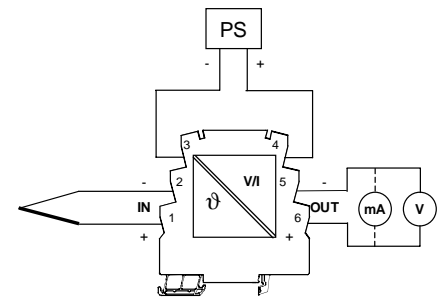

Technical data

Input

Sensor
Temperature input range

Output

Output voltage/Output current
Load resistance voltage/Current
Accuracy
Temperature coefficient
Step response time
Wire break detection
Residual ripple

General data

Supply voltage
Power consumption
Current-carrying cap. of cross-connect.
Operation temperature
Storage temperature
Default settings
Approvals

Insulation coordinates

Standards
EMC standards
Rated voltage
Impulse withstand voltage
Isolation voltage Input, output/
Overvoltage category
Pollution severity
Clearance & creepage path

thermo-elements according IEC 584, type: K
0...1000 °C

0...10V / 0...5V/0(4)...20 mA

$\geq 10 \text{ k}\Omega / < = 600 \Omega$

$< 0.6 \%$ of measuring range

$\leq 250 \text{ ppm/K}$ of final value

$< 0.7 \text{ s}$

output value: $> 20 \text{ mA}, > 10 \text{ V}$

$< 20 \text{ mVeff}$

24 Vdc +/- 10 %

approx. 0.6 W

$\leq 20 \text{ A}$

0 °C...+55 °C

-20 °C...+85 °C

0...20mA

CE / ESD / cURus

EN 50178, EN 60584, IEC 584

EN 50081, EN 50082, EN 55011, EN 61000-6-2, EN 61326

100 V

1.5 kV

500 Veff/

III

2

$\geq 1.5 \text{ mm}$

Dimensions

Clamping range (rating- / min. / max.) mm²
Length x width x height mm

Information

Screw connection

2.50 / 0.50 / 2.50

88.0 x 6.1 x 97.8

Tension clamp c.

1.50 / 0.50 / 2.50

92.0 x 6.1 x 97.8

Tu=23°C, single module

Ordering data

Type of connection

Screw connection
Tension clamp c.

Type

MAS Thermo-K 0...1000°C Output select1
MAZ Thermo-K 0...1000°C Output select1

Qty.

Order No.

8594830000

8594860000

Information

Accessories

Information

Voltage supply 24V and 0V with ZQV 4N/x cross-connection

Articles with coloured order number are kept permanently in stock at the central warehouse in Germany.
Delivery times see page X.2

Thermo element, signal isolator/converter

Thermo disconnecter converter type: J

- 2-way isolation between input/output and voltage supply
- Cold-junction compensation
- Linearization
- Output can be switched calib. via DIP-switch

Thermo J Output Select

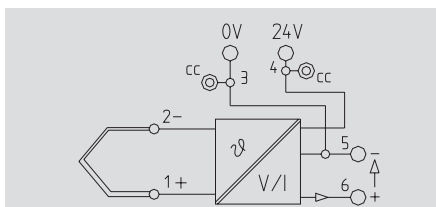
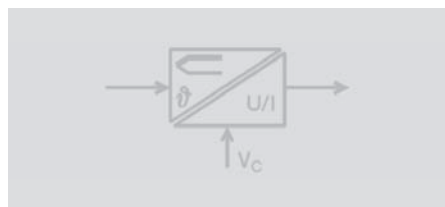
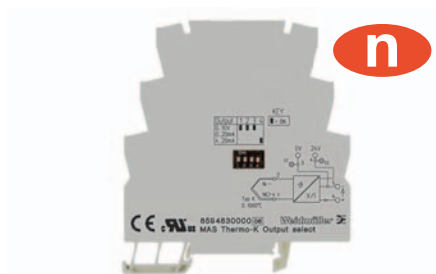

Output	Switch			
	1	2	3	4
0 ... 10 V	■	■	■	□
0 ... 20 mA	□	□	□	□
4 ... 20 mA	□	□	□	■
0 ... 5 V	■	■	■	■

■ = on
□ = off

Connection

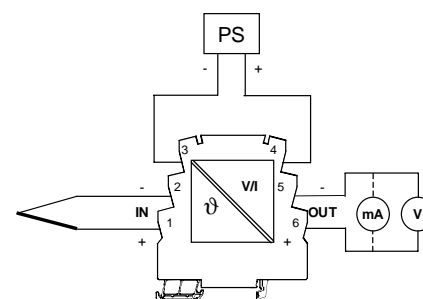

Technical data

Input

Sensor
Temperature input range

Output

Output voltage/Output current
Load resistance voltage/Current
Accuracy
Temperature coefficient
Step response time
Wire break detection
Residual ripple

General data

Supply voltage
Power consumption
Current-carrying cap. of cross-connect.
Operation temperature
Storage temperature
Default settings
Approvals

Insulation coordinates

Standards
EMC standards
Rated voltage
Impulse withstand voltage
Isolation voltage Input, output/
Overvoltage category
Pollution severity
Clearance & creepage path

thermo-elements according IEC 584, type: J
0...700 °C

0...10V / 0...5V/0(4)...20 mA

$\geq 10 \text{ k}\Omega / < = 600 \Omega$

$< 0.7 \%$ of measuring range

$\leq 250 \text{ ppm/K}$ of final value

$< 0.7 \text{ s}$

output value: $> 20 \text{ mA}$, $> 10 \text{ V}$

$< 20 \text{ mVeff}$

24 Vdc +/- 10 %

approx. 0.6 W

$\leq 20 \text{ A}$

0 °C...+55 °C

-20 °C...+85 °C

0...20mA

CE / ESD / cURus

EN 50178, EN 60584, IEC 584

EN 50081, EN 50082, EN 55011, EN 61000-6-2, EN 61326

100 V

1.5 kV

500 Veff/

III

2

$\geq 1.5 \text{ mm}$

Dimensions

Clamping range (rating- / min. / max.) mm²
Length x width x height mm

Information

Screw connection

2.50 / 0.50 / 2.50
88.0 x 6.1 x 97.8

Tension clamp c.

1.50 / 0.50 / 2.50
92.0 x 6.1 x 97.8

Tu=23°C, single module

Ordering data

Type of connection

Screw connection
Tension clamp c.

Type	Qty.	Order No.
MAS Thermo-J 0...700°C Output select	1	8615210000
MAZ Thermo-J 0...700°C Output select	1	8615240000

Information

Accessories

Information

Voltage supply 24V and 0V with ZQV 4N/x cross-connection

Thermo element, signal isolator/converter

Thermo disconnecter converter Type: PRO Thermo K, J, T, E, N, R, S, B

- 3-way isolation
- Calibration not necessary
- Cold-junction compensation
- Output signal selectable
- Power sup. can be cross-conn. by jumper

PRO Thermo

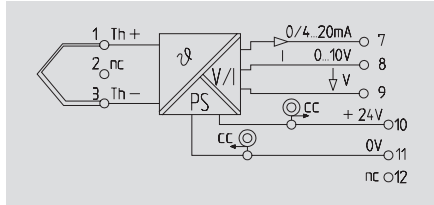
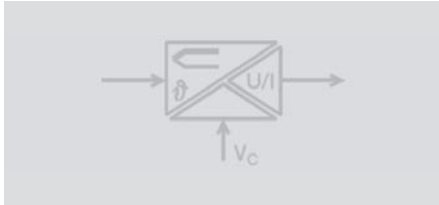

Technical data

Input	
Sensor	thermo-elements (IEC 584) type: K,J,T,E,N,R,S,B
Temperature input range	-200...+1820 °C
Output	
Output voltage/Output current	0...10 V/0(4)...20 mA
Load resistance/voltage/Current	>= 1 kΩ / <= 600 Ω
Offset current/Offset voltage	max. 100 μA/max. 0.05 V
Step response time	max. 1.4 s; with filter: max. 7.5 ms
Line resistance in measuring circuit	50 Ω
Wire break detection	LED flashes (output value > 20mA, > 10V)
Fine adjustment	>= +/- 5 % (switchable)
Status indicator	active: LED on/cond. broken: LED flashing/Error: LED off
General data	
Supply voltage	24 Vdc +/- 25 %
Power consumption	800...850...950 mW at Iout= 20 mA
Current-carrying cap. of cross-connect.	<= 2 A
Operation temperature	0 °C...+55 °C
Storage temperature	-20 °C...+85 °C
Default settings	type K; 0...1000°C; 4...20mA; filter: off; man. adjustment: off
Approvals	GL / CE / cURus
Insulation coordinates	
Standards	EN 50178, EN 60584, IEC 584
EMC standards	EN 50081, EN50082, EN55011
Rated voltage	300 V
Impulse withstand voltage	4 kV
Isolation voltage Input, output/	2 kVeff / 5s/
Overvoltage category	III
Pollution severity	2
Clearance & creepage path	>= 3 mm

Dimensions	
Clamping range (rating- / min. / max.)	mm²
Length x width x height	mm
Information	
	TU=23°C, single module

Ordering data

Type of connection	
Screw connection	
Tension clamp c.	

Information

Accessories

Information	
	Voltage supply 24V and 0V with ZQV 2.5N/2 cross-connection

Screw connection	Tension clamp c.	
2.50 / 0.50 / 2.50	1.50 / 0.50 / 2.50	
92.4 x 17.5 x 112.4	92.4 x 17.5 x 112.4	
Type	Qty.	Order No.
WAS5 PRO Thermo	1	8560720000
WAZ5 PRO Thermo	1	8560730000

Select of thermocoupler			Selection of minimum temperature				
Typ	SW1			ϑ _{min}	SW1		
K	<input checked="" type="checkbox"/>	<input checked="" type="checkbox"/>	<input checked="" type="checkbox"/>	0°C	<input checked="" type="checkbox"/>	<input checked="" type="checkbox"/>	<input checked="" type="checkbox"/>
J	<input type="checkbox"/>	<input checked="" type="checkbox"/>	<input checked="" type="checkbox"/>	-10°C	<input checked="" type="checkbox"/>	<input checked="" type="checkbox"/>	<input type="checkbox"/>
T	<input checked="" type="checkbox"/>	<input type="checkbox"/>	<input type="checkbox"/>	-20°C	<input checked="" type="checkbox"/>	<input checked="" type="checkbox"/>	<input type="checkbox"/>
E	<input type="checkbox"/>	<input type="checkbox"/>	<input checked="" type="checkbox"/>	-30°C	<input checked="" type="checkbox"/>	<input type="checkbox"/>	<input type="checkbox"/>
N	<input checked="" type="checkbox"/>	<input checked="" type="checkbox"/>	<input type="checkbox"/>	-40°C	<input checked="" type="checkbox"/>	<input type="checkbox"/>	<input type="checkbox"/>
R	<input type="checkbox"/>	<input checked="" type="checkbox"/>	<input type="checkbox"/>	-50°C	<input checked="" type="checkbox"/>	<input type="checkbox"/>	<input type="checkbox"/>
S	<input checked="" type="checkbox"/>	<input type="checkbox"/>	<input type="checkbox"/>	-100°C	<input checked="" type="checkbox"/>	<input type="checkbox"/>	<input type="checkbox"/>
B	<input type="checkbox"/>	<input type="checkbox"/>	<input type="checkbox"/>	-150°C	<input type="checkbox"/>	<input type="checkbox"/>	<input type="checkbox"/>
				-200°C	<input type="checkbox"/>	<input checked="" type="checkbox"/>	<input checked="" type="checkbox"/>
				+50°C	<input type="checkbox"/>	<input checked="" type="checkbox"/>	<input checked="" type="checkbox"/>
				+100°C	<input type="checkbox"/>	<input checked="" type="checkbox"/>	<input checked="" type="checkbox"/>
				+150°C	<input type="checkbox"/>	<input checked="" type="checkbox"/>	<input checked="" type="checkbox"/>
				+200°C	<input type="checkbox"/>	<input type="checkbox"/>	<input checked="" type="checkbox"/>
				+250°C	<input type="checkbox"/>	<input type="checkbox"/>	<input checked="" type="checkbox"/>
				500°C	<input type="checkbox"/>	<input type="checkbox"/>	<input checked="" type="checkbox"/>
				Special range	<input type="checkbox"/>	<input type="checkbox"/>	<input type="checkbox"/>

Selection of temperature span					Selection of output	
Span	SW2				Output	SW2
100°C	<input checked="" type="checkbox"/>	<input checked="" type="checkbox"/>	<input checked="" type="checkbox"/>	<input checked="" type="checkbox"/>	0...10V	<input checked="" type="checkbox"/>
150°C	<input checked="" type="checkbox"/>	<input checked="" type="checkbox"/>	<input checked="" type="checkbox"/>	<input type="checkbox"/>	0...20mA	<input type="checkbox"/>
200°C	<input checked="" type="checkbox"/>	<input checked="" type="checkbox"/>	<input type="checkbox"/>	<input type="checkbox"/>	4...20mA	<input type="checkbox"/>
250°C	<input checked="" type="checkbox"/>	<input checked="" type="checkbox"/>	<input type="checkbox"/>	<input type="checkbox"/>		
300°C	<input checked="" type="checkbox"/>	<input checked="" type="checkbox"/>	<input type="checkbox"/>	<input type="checkbox"/>		
350°C	<input checked="" type="checkbox"/>	<input checked="" type="checkbox"/>	<input type="checkbox"/>	<input type="checkbox"/>		
400°C	<input checked="" type="checkbox"/>	<input checked="" type="checkbox"/>	<input type="checkbox"/>	<input type="checkbox"/>		
450°C	<input checked="" type="checkbox"/>	<input checked="" type="checkbox"/>	<input type="checkbox"/>	<input type="checkbox"/>		
500°C	<input checked="" type="checkbox"/>	<input type="checkbox"/>	<input checked="" type="checkbox"/>	<input checked="" type="checkbox"/>		
550°C	<input checked="" type="checkbox"/>	<input type="checkbox"/>	<input checked="" type="checkbox"/>	<input type="checkbox"/>		
600°C	<input checked="" type="checkbox"/>	<input type="checkbox"/>	<input checked="" type="checkbox"/>	<input type="checkbox"/>		
650°C	<input checked="" type="checkbox"/>	<input type="checkbox"/>	<input checked="" type="checkbox"/>	<input type="checkbox"/>		
700°C	<input checked="" type="checkbox"/>	<input type="checkbox"/>	<input checked="" type="checkbox"/>	<input type="checkbox"/>		
750°C	<input checked="" type="checkbox"/>	<input type="checkbox"/>	<input checked="" type="checkbox"/>	<input type="checkbox"/>		
800°C	<input checked="" type="checkbox"/>	<input type="checkbox"/>	<input checked="" type="checkbox"/>	<input type="checkbox"/>		
850°C	<input checked="" type="checkbox"/>	<input type="checkbox"/>	<input checked="" type="checkbox"/>	<input type="checkbox"/>		
900°C	<input type="checkbox"/>	<input checked="" type="checkbox"/>	<input checked="" type="checkbox"/>	<input checked="" type="checkbox"/>		
950°C	<input type="checkbox"/>	<input checked="" type="checkbox"/>	<input checked="" type="checkbox"/>	<input type="checkbox"/>		
1000°C	<input type="checkbox"/>	<input checked="" type="checkbox"/>	<input checked="" type="checkbox"/>	<input type="checkbox"/>		
1050°C	<input type="checkbox"/>	<input checked="" type="checkbox"/>	<input checked="" type="checkbox"/>	<input type="checkbox"/>		
1100°C	<input type="checkbox"/>	<input checked="" type="checkbox"/>	<input checked="" type="checkbox"/>	<input type="checkbox"/>		
1150°C	<input type="checkbox"/>	<input checked="" type="checkbox"/>	<input checked="" type="checkbox"/>	<input type="checkbox"/>		
1200°C	<input type="checkbox"/>	<input checked="" type="checkbox"/>	<input checked="" type="checkbox"/>	<input type="checkbox"/>		
1250°C	<input type="checkbox"/>	<input checked="" type="checkbox"/>	<input checked="" type="checkbox"/>	<input type="checkbox"/>		
1300°C	<input type="checkbox"/>	<input type="checkbox"/>	<input checked="" type="checkbox"/>	<input checked="" type="checkbox"/>		
1350°C	<input type="checkbox"/>	<input type="checkbox"/>	<input checked="" type="checkbox"/>	<input type="checkbox"/>		
1400°C	<input type="checkbox"/>	<input type="checkbox"/>	<input checked="" type="checkbox"/>	<input type="checkbox"/>		
1450°C	<input type="checkbox"/>	<input type="checkbox"/>	<input checked="" type="checkbox"/>	<input type="checkbox"/>		
1500°C	<input type="checkbox"/>	<input type="checkbox"/>	<input checked="" type="checkbox"/>	<input type="checkbox"/>		
1600°C	<input type="checkbox"/>	<input type="checkbox"/>	<input checked="" type="checkbox"/>	<input type="checkbox"/>		
1700°C	<input type="checkbox"/>	<input type="checkbox"/>	<input checked="" type="checkbox"/>	<input checked="" type="checkbox"/>		
1800°C	<input type="checkbox"/>	<input type="checkbox"/>	<input checked="" type="checkbox"/>	<input type="checkbox"/>		

Switching on the manual fine adjustment	
man. adjust.	SW1
off	<input type="checkbox"/>
on	<input checked="" type="checkbox"/>

Switching on the filter function	
Filter	SW2
off	<input type="checkbox"/>
on	<input checked="" type="checkbox"/>

Temperature coefficient	
K -200°C...-150°C	± (5K + 0,1% of set range)
-150°C...1200°C	± (3K + 0,1% of set range)
1200°C...1372°C	± (4K + 0,1% of set range)
J -200°C...-150°C	± (4K + 0,1% of set range)
-150°C...1200°C	± (3K + 0,1% of set range)
T -200°C...-150°C	± (5K + 0,1% of set range)
-150°C...400°C	± (3K + 0,1% of set range)
E -200°C...-150°C	± (4K + 0,1% of set range)
-150°C...1000°C	± (3K + 0,1% of set range)
N -200°C...-150°C	± (6K + 0,1% of set range)
-150°C...1300°C	± (3K + 0,1% of set range)
R -50°C...200°C	± (10K + 0,1% of set range)
200°C...1760°C	± (6K + 0,1% of set range)
S -50°C...200°C	± (10K + 0,1% of set range)
200°C...1760°C	± (6K + 0,1% of set range)
B 50°C...250°C	± (25K + 0,1% of set range)
250°C...500°C	± (10K + 0,1% of set range)
500°C...1820°C	± (6K + 0,1% of set range)

Articles with coloured order number are kept permanently in stock at the central warehouse in Germany. Delivery times see page X.2

Frequency signal isolator/converter

DC/f disconnecter converter

By the conversion of analog signals to frequency it is possible to read in analog signals out of the array via the counter-inputs of the controller.

MCZ VFC

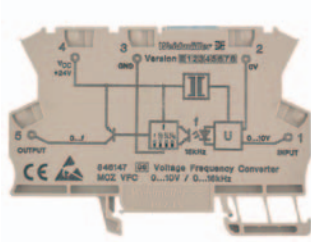

MCZ CFC

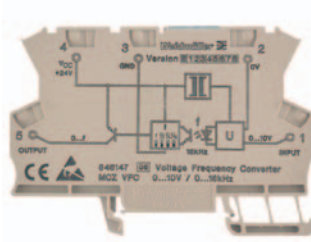

MCZ CFC

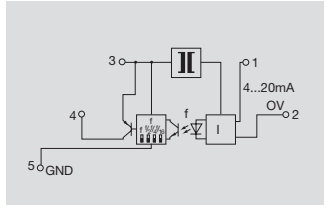
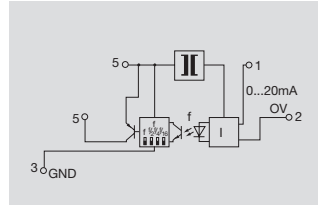
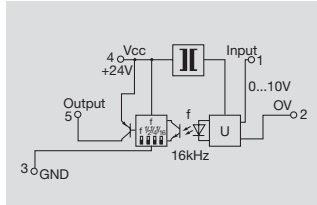
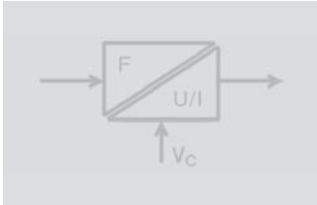
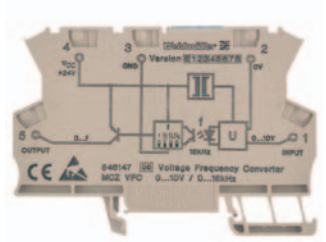

Technical data

Input

Input voltage/Input current
Max. voltage/Max. current
Input resistance voltage/Current
Voltage drop

Output

Output frequency/
Output level
Output current
Fine adjustment
Accuracy
Temperature coefficient
Status indicator

General data

Supply voltage
Current consumption
Current-carrying cap. of cross-connect.
Operation temperature
Storage temperature
Approvals

Insulation coordinates

Standards
EMC standards
Rated voltage
Impulse withstand voltage
Isolation voltage Input, output
Overvoltage category
Pollution severity
Clearance & creepage path

0...10 V/
30 V/
100 kΩ/

0...1/ 4/ 8/ 16 kHz/
PNP, Ub-0.7 V
max. 20 mA
+/- 10 %, internal
0.2% of FSR
<= 250 ppm/K
LED, pulsing

24 Vdc +/- 10 %
14 mA without load
<= 20 A
0 °C...+50 °C
-20 °C...+85 °C
CE / ESD

EN 50178
EN 50081, EN50082, EN55011
100 V
1.5 kV
1 kVdc
III
2
>= 1.5mm

Tension clamp c.

1.50 / 0.50 / 1.50
91.0 x 6.0 x 63.2

/0...20 mA
/50 mA
/50 Ω
1 V at 20 mA

0...1/ 4/ 8/ 16 kHz/
PNP, Ub-0.7 V
max. 20 mA
+/- 10 %, internal
0.2% of FSR
<= 250 ppm/K
LED, pulsing

24 Vdc +/- 10 %
14 mA without load
0 °C...+50 °C
-20 °C...+85 °C
CE / ESD

EN 50178
EN 50081, EN50082, EN55011
100 V
1.5 kV
1 kVdc
III
2
>= 1.5mm

Tension clamp c.

1.50 / 0.50 / 1.50
91.0 x 6.0 x 63.2

/4...20 mA (current loop)
/50 mA
/
5.8...6.4 V at 20 mA

0...1/ 4/ 8/ 16 kHz/
PNP, Ub-0.7 V
max. 20 mA
+/- 10 %, internal
0.15 % of FSR
<= 250 ppm/K
LED, pulsing

24 Vdc +/- 20 %
14 mA without load
0 °C...+50 °C
-20 °C...+85 °C
CE / ESD

EN 50178
EN 50081, EN50082, EN55011
150 V
2.5 kV
III
2
>= 2 mm

Tension clamp c.

1.50 / 0.50 / 1.50
91.0 x 6.0 x 63.2

Without DC/DC-converter input is current-loop-fed

Dimensions

Clamping range (rating- / min. / max.) mm²
Length x width x height mm

Information

Ordering data

Type of connection

Tension clamp c.

Type	(Qty.=1)	Order No.
MCZ VFC 0-10V		8461470000

Information

Type	(Qty.=1)	Order No.
MCZ CFC 0-20MA		8461480000

Information

Type	(Qty.=1)	Order No.
MCZ CFC 4-20MA		8461490000

Information

Accessories

Information

Voltage supply 24V,0V and GND with ZQV 4/x cross-connection

Voltage supply 24V,0V and GND with ZQV 4/x cross-connection

Voltage supply 24V,0V and GND with ZQV 4/x cross-connection

Frequency signal isolator/converter

f/DC disconnecter converter

- 3-way isolation
- Max. input frequency 100 kHz
- Input and output adjustable via DIP-switch
- Calibration not necessary
- Special partitions can be programmed

PRO Frequency

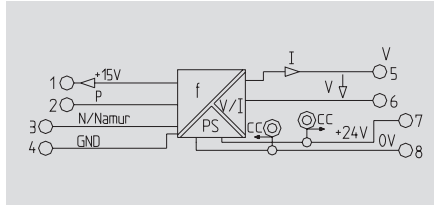
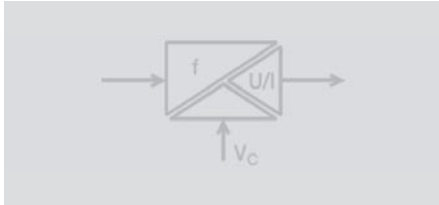

Technical data

Input

Sensor/
Rated input level
Resolution

Output

Output voltage/Output current
Load resistance voltage/Current
Offset current/Offset voltage

Accuracy
Temperature coefficient
Step response time
Status indicator

General data

Supply voltage
Power consumption
Current-carrying cap. of cross-connect.
Operation temperature
Storage temperature
Default settings
Approvals

Insulation coordinates

Standards
EMC standards
Rated voltage
Impulse withstand voltage
Isolation voltage Input, output/
Overvoltage category
Pollution severity
Clearance & creepage path

Dimensions

Clamping range (rating- / min. / max.) mm²
Length x width x height mm

Information

Ordering data

Type of connection

Screw connection
Tension clamp c.

Information

Accessories

Information

2-, 3-wire PNP/NPN, namur initiator, push-pull step/
threshold / hysteresis: namur: ca 1.7 mA/ca 0.2 mA;
NPN: ca 6.5 V/ca 0.2V; PNP: ca 6.7V/ca 0.5V
0.1 mHz resp. 5 ppm of measurement value

0...10 V/0(4)...20 mA

>= 1 kΩ / <= 600 Ω

max. 100 μA/max. 0.05 V

0.2 % of output range

max. 200 ppm/K of output range

360 ms + 2-fold period time of input frequency

LED green

24 Vdc +/- 25 %

max. 1.6 W at I_{out}= 20 mA

<= 2 A

0 °C...+55 °C

-20 °C...+85 °C

0...10kHz / 4...20mA

CE / ESD / cURus

EN 50178 (safe separation)

EN 50081, EN 50082, EN 55011, EN 61000-6-2, EN 61326

300 V

6 kV

4 kVeff / 5s/

III

>= 5.5 mm

Screw connection

2.50 / 0.50 / 2.50

Tension clamp c.

1.50 / 0.50 / 2.50

TU=23°C, single module

Type

WAS4 PRO Freq

Qty.

1

Order No.

8581180000

WAZ4 PRO Freq

1

8581190000

Voltage supply 24V and 0V with ZQV 2.5N/2
cross-connection

Selecting the operating mode

Operating mode	Switch 2	
	3	4
0...f _{max}	<input type="checkbox"/>	<input type="checkbox"/>
f _{min} ...f _{max}	<input type="checkbox"/>	<input checked="" type="checkbox"/>
saving	<input checked="" type="checkbox"/>	<input type="checkbox"/>
f _{min}	<input checked="" type="checkbox"/>	<input type="checkbox"/>

$$f = (A+B) \times C$$

Selecting the frequency

A	Switch 1			
	1	2	3	4
0	<input type="checkbox"/>	<input type="checkbox"/>	<input type="checkbox"/>	<input type="checkbox"/>
1	<input type="checkbox"/>	<input type="checkbox"/>	<input type="checkbox"/>	<input checked="" type="checkbox"/>
2	<input type="checkbox"/>	<input type="checkbox"/>	<input checked="" type="checkbox"/>	<input type="checkbox"/>
3	<input type="checkbox"/>	<input type="checkbox"/>	<input checked="" type="checkbox"/>	<input checked="" type="checkbox"/>
4	<input type="checkbox"/>	<input checked="" type="checkbox"/>	<input type="checkbox"/>	<input type="checkbox"/>
5	<input type="checkbox"/>	<input checked="" type="checkbox"/>	<input checked="" type="checkbox"/>	<input type="checkbox"/>
6	<input type="checkbox"/>	<input checked="" type="checkbox"/>	<input checked="" type="checkbox"/>	<input type="checkbox"/>
7	<input type="checkbox"/>	<input checked="" type="checkbox"/>	<input checked="" type="checkbox"/>	<input checked="" type="checkbox"/>
8	<input checked="" type="checkbox"/>	<input type="checkbox"/>	<input type="checkbox"/>	<input type="checkbox"/>
9	<input checked="" type="checkbox"/>	<input type="checkbox"/>	<input type="checkbox"/>	<input checked="" type="checkbox"/>
10	<input checked="" type="checkbox"/>	<input type="checkbox"/>	<input checked="" type="checkbox"/>	<input type="checkbox"/>
11	<input checked="" type="checkbox"/>	<input type="checkbox"/>	<input checked="" type="checkbox"/>	<input checked="" type="checkbox"/>
12	<input checked="" type="checkbox"/>	<input checked="" type="checkbox"/>	<input type="checkbox"/>	<input type="checkbox"/>
13	<input checked="" type="checkbox"/>	<input checked="" type="checkbox"/>	<input checked="" type="checkbox"/>	<input type="checkbox"/>
14	<input checked="" type="checkbox"/>	<input checked="" type="checkbox"/>	<input type="checkbox"/>	<input type="checkbox"/>
15	<input checked="" type="checkbox"/>	<input checked="" type="checkbox"/>	<input checked="" type="checkbox"/>	<input checked="" type="checkbox"/>

Selecting the frequency

B	Switch 1			
	5	6	7	8
0	<input type="checkbox"/>	<input type="checkbox"/>	<input type="checkbox"/>	<input type="checkbox"/>
0,1	<input type="checkbox"/>	<input type="checkbox"/>	<input type="checkbox"/>	<input checked="" type="checkbox"/>
0,2	<input type="checkbox"/>	<input type="checkbox"/>	<input checked="" type="checkbox"/>	<input type="checkbox"/>
0,3	<input type="checkbox"/>	<input type="checkbox"/>	<input checked="" type="checkbox"/>	<input checked="" type="checkbox"/>
0,4	<input type="checkbox"/>	<input checked="" type="checkbox"/>	<input type="checkbox"/>	<input type="checkbox"/>
0,5	<input type="checkbox"/>	<input checked="" type="checkbox"/>	<input checked="" type="checkbox"/>	<input type="checkbox"/>
0,6	<input type="checkbox"/>	<input checked="" type="checkbox"/>	<input checked="" type="checkbox"/>	<input type="checkbox"/>
0,7	<input type="checkbox"/>	<input checked="" type="checkbox"/>	<input checked="" type="checkbox"/>	<input checked="" type="checkbox"/>
0,8	<input checked="" type="checkbox"/>	<input type="checkbox"/>	<input type="checkbox"/>	<input type="checkbox"/>
0,9	<input checked="" type="checkbox"/>	<input type="checkbox"/>	<input type="checkbox"/>	<input checked="" type="checkbox"/>

Selecting the frequency

C	Switch 2	
	1	2
x1	<input type="checkbox"/>	<input type="checkbox"/>
x10	<input type="checkbox"/>	<input type="checkbox"/>
x100	<input checked="" type="checkbox"/>	<input type="checkbox"/>
x1000	<input checked="" type="checkbox"/>	<input checked="" type="checkbox"/>

Selecting the output

Output	Switch 2			
	5	6	7	8
0...10 V	<input checked="" type="checkbox"/>	<input type="checkbox"/>	<input checked="" type="checkbox"/>	<input checked="" type="checkbox"/>
0...20 mA	<input type="checkbox"/>	<input type="checkbox"/>	<input type="checkbox"/>	<input type="checkbox"/>
4...20 mA	<input type="checkbox"/>	<input checked="" type="checkbox"/>	<input type="checkbox"/>	<input type="checkbox"/>
0...5 V	<input checked="" type="checkbox"/>	<input checked="" type="checkbox"/>	<input checked="" type="checkbox"/>	<input checked="" type="checkbox"/>

Special range (frequency generator is required)

Funktion	Switch 2			
	1	2	3	4
save min. frequency	<input type="checkbox"/>	<input checked="" type="checkbox"/>	<input checked="" type="checkbox"/>	<input checked="" type="checkbox"/>
save max. frequency	<input checked="" type="checkbox"/>	<input type="checkbox"/>	<input checked="" type="checkbox"/>	<input checked="" type="checkbox"/>
select special range	<input checked="" type="checkbox"/>	<input checked="" type="checkbox"/>	<input checked="" type="checkbox"/>	<input checked="" type="checkbox"/>

■ = ein
□ = aus

Application

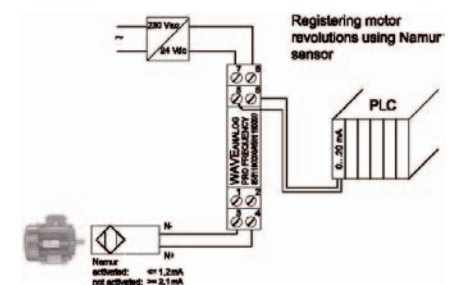

Frequency signal transformer

WAVEANALOGUE PRO Frequency

Connection configuration of the sensors

3-wire initiator with PNP output

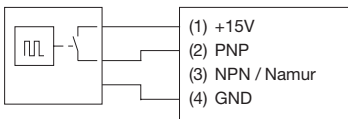

3-wire initiator with PNP output and external supply

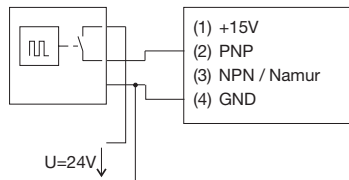

3-wire initiator with NPN output

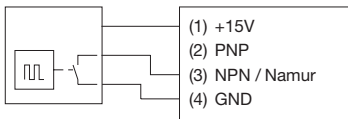

3-wire initiator with NPN output and external supply

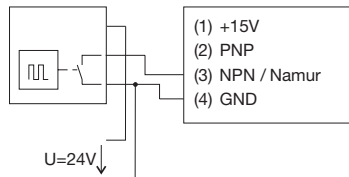

2-wire initiator

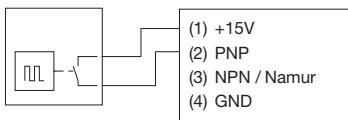

(residual current < 1 mA)

Namur initiator

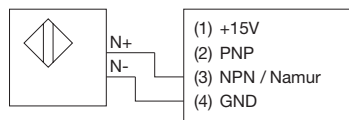

Push pull output cascade

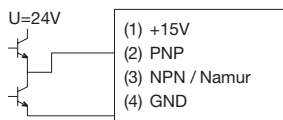

Setting help for any input and output values

Setting the input range using the DIP switches (no frequency generator required):

There are 2 different cases:

1. Lower measuring frequency = 0 Hz

- Choose operating mode "= ... fmax" S2.3 = 0 and S2.4 = 0
- Set the upper measuring frequency using DIP switches S1 and S2.1, S2.2 (see table)
- That's all

2. Lower measuring frequency ≠ 0 Hz

- First the lower measuring frequency must be saved. Select mode "save fmin". S2.3 = 1 and S2.4 = 0. Set the frequency using DIP switches S1 and S2.1, S2.2 (see table)
- To save the frequency, briefly connect the module to the power supply.
- Select mode "fmin...fmax" S2.3 = 0 and S2.4 = 1
- Set the upper measuring frequency using DIP switches S1 and S2.1, S2.2 (see table).
- That's all.

Adjusting the input range using a frequency generator

- Select the switch setting for saving the frequency: S2.1 = 0, S2.2 = 1, S2.3 = 1 and S2.4 = 1
- Apply min. frequency to the module
- Connect the module to the power supply
- The LED lights up when the input frequency is being measured. If the LED goes off, the frequency has been saved and the module can be disconnected from the power supply again.
- Repeat with max. frequency: S2.1 = 1, S2.2 = 0, S2.3 = 1 and S2.4 = 1
- Select special range: S2.1 = 1, S2.2 = 1, S2.3 = 1 and S2.4 = 1

Bridge measuring converter

Configurable

- 3-way isolation
- Input and output selectable via DIP-switch
- Calibration not necessary
- Inverse output signal

PRO BRIDGE



Switch position/setting options

Input voltage	SW 1									
	1	2	3	4	5	6	7	8	9	10
0...10 mV										
0...20 mV										
0...50 mV										
0...100 mV										
0...200 mV										
0...500 mV										
-10 mV...10 mV										
-20 mV...20 mV										
-50 mV...50 mV										
-100 mV...100 mV										
-200 mV...200 mV										
-500 mV...500 mV										
Ausgang										
0...+10 V										
0...+5 V										
0...20 mA										
4...20 mA										
Bridge supply voltage										
+10V										
+5V										
+4,8...+10,2V adjustable										
+4,8...+10,2V adjustable man. adjustment and offset possible										
Transmission method										
standard output signal										
inverse output signal										

■ = on
□ = off

Status LED

LED on	normal operating
LED off	Error
LED blinks slow	measurement range undershoot $U_{in} < U_{max} + 10\%$
LED blinks fast	measurement range overshoot $U_{in} < U_{max} - 10\%$

Application

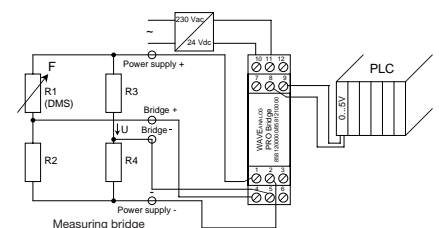

Example for bridge supply voltage

Temperature adjustment:

Input voltage	0...10 mA
Output	0...10 V
Bridge supply voltage	+4,8...10,2 V
Bridge excitation	1 mV/V

(Declaration from manufacturer)

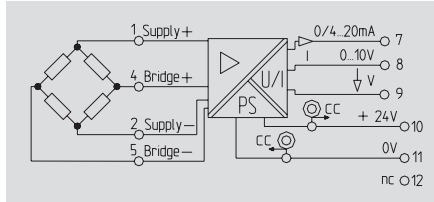
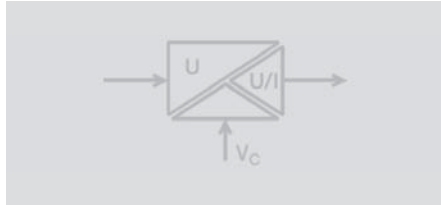
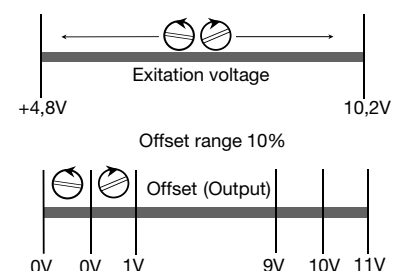

Technical data

Input

Input voltage/
Input resistance voltage

-500mV...+500mV/
> 1 M Ω

Output

Output voltage/Output current
Load resistance voltage/Current
Offset current/Offset voltage

0...5 V, 5...0 V, 10...0 V, 0...10 V/
0...20 mA, 20...0 mA, 4...20 mA, 20...4 mA
>= 1 k Ω / <= 600 Ω

Accuracy

Temperature coefficient

max. 100 μ A/max. 0.05 V

Step response time

0.3 % of output range

Status indicator

+/- 250 ppm/K of output range

Wire break detection

typ. < 200 ms

Bridge supply voltage

LED green

General data

Supply voltage
Power consumption
Current-carrying cap. of cross-connect.
Operation temperature
Storage temperature
Default settings
Approvals

output: 0 V resp. 0/4 mA

+10 V, +5 V, 4,8...10,2 V; offset adjustable; max. 40mA

Insulation coordinates

Standards
EMC standards
Rated voltage
Impulse withstand voltage
Isolation voltage Input, output/
Overvoltage category
Pollution severity
Clearance & creepage path

24 Vdc +/- 25 %

max. 1.9 W at I_{out}= 20 mA

<= 2 A

0 °C...+55 °C

-20 °C...+85 °C

-500 mV...+500 mV / 0...10 V / + 10 V / standard

CE / ESD / cURus

Dimensions

Clamping range (rating- / min. / max.) mm²
Length x width x height mm

Screw connection

2.50 / 0.50 / 2.50 1.50 / 0.50 / 2.50
92.4 x 17.5 x 112.4 92.4 x 17.5 x 112.4

Tension clamp c.

Information

TU=23°C, single module

Ordering data

Type of connection

Screw connection
Tension clamp c.

Type	Qty.	Order No.
WAS5 PRO Bridge	1	858120000
WAZ5 PRO Bridge	1	858121000

Information

Accessories

Information

Voltage supply 24V and 0V with ZQV 2.5N/2
cross-connection

Serial interface converter

RS232/RS485/422

- 3-way isolation
- RS232 connection via SUB-D 9
- RS485/422, TTY shield connection via KLBÜ
- DTE or DCE assignment selectable
- Bidirectional communication

RS232/RS485/422

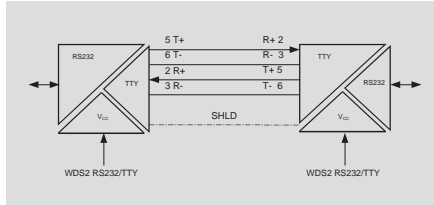
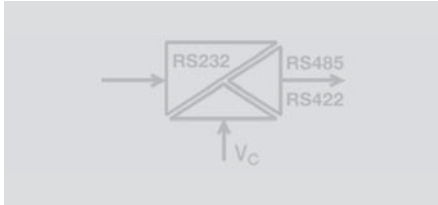

Technical data

RS232

Connection/Input current
Assignment

RS485/422

Terminating resistors
Connection
Bit distortion
Bit delay
Control of data direction/
Shield connection
Status indicator
Max. bit rate
Transmission channels
Transmission distance

General data

Supply voltage
Power consumption
Operation temperature
Storage temperature
Approvals

Insulation coordinates

Standards
EMC standards
Rated voltage
Impulse withstand voltage
Pollution severity
Overvoltage category
Clearance & creepage path
Isolation voltage Input, output

SUB-D9 (pin)/

DTE/DCE switchable via DIP-Switch

pull down/ pull up via DIP-switch

BLZ screw connection

< 1.5%

<= 3µs

selfcontrolling or via RS232 RTS/CTS/

KLBÜ 4-6/Z1

LED green: supply voltage, TxD, RxD

115.2 kBit/s

half duplex (RS485-2 wire)

full duplex (RS485-4 wire and RS422)

max. 1200m twisted pair

24 Vdc +/- 25 %

approx. 1.5 W

0 °C...+55 °C (horiz. mounting)

-20 °C...+85 °C

CE / ESD / cURus

EN 50178

EN 61000-6-2, EN 61000-6-4, EN 55011

between adjacent electric circuits: 300 V

between electric circuits and PE: 150 V

4 kV

2

III

between adjacent electric circuits: 3mm

between electric circuits and PE: 1.5mm

2 kVdc / 1 min.

Dimensions

Clamping range (rating- / min. / max.) mm²
Length x width x height mm

Information

Screw connection

2.50 / 0.50 / 2.50
92.4 x 22.5 x 112.4

Tu=23°C, single module

Ordering data

Type of connection

Screw connection

Type	Qty.	Order No.
WDS2 RS232/RS485/422	1	8615700000

Information

Accessories

Information

Voltage supply 24V and 0V with ZQV 2.5N/2
cross-connection

Serial interface converter

RS232/TTY

- 3-way isolation
- RS232 connection via SUB-D 9
- RS485/422, TTY shield connection via KLBÜ
- DTE or DCE assignment selectable
- Bidirectional communication

RS232/TTY

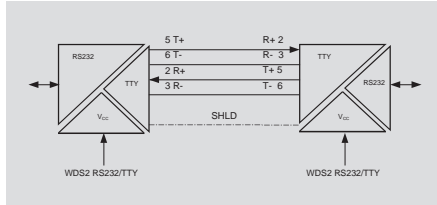
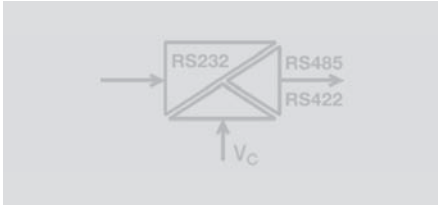

Technical data

RS232

Connection/Input current
Assignment

TTY

Connection
Bit distortion
Bit delay
Burden
Shield connection/
Status indicator
Max. bit rate
Transmission channels
Transmission distance

General data

Supply voltage
Power consumption
Operation temperature
Storage temperature
Approvals

Insulation coordinates

Standards
EMC standards
Rated voltage
Impulse withstand voltage
Pollution severity
Overvoltage category
Clearance & creepage path
Isolation voltage Input, output

SUB-D9 (pin)/

DTE/DCE switchable via DIP-Switch

BLZ screw terminal

< 1.5%

<= 3 µs

<= 500 Ω

KLBÜ 4-6 Z/1/

LED green: supply voltage, TxD, RxD

19.2 kBit/s

full duplex

max. 1000m twisted pair

24 Vdc +/- 25 %

approx. 0.8 W

0 °C...+55 °C (horiz. mounting)

-20 °C...+85 °C

CE / ESD / cURus

EN 50178

EN 61000-6-2, EN 61000-6-4, EN 55011

between adjacent electric circuits: 300 V

between electric circuits and PE: 150 V

4 kV

2

III

between adjacent electric circuits: 3mm

between electric circuits and PE: 1.5mm

2 kVdc / 1 min.

Dimensions

Clamping range (rating- / min. / max.) mm²
Length x width x height mm

Information

Screw connection

2.50 / 0.50 / 2.50
92.4 x 22.5 x 112.4

Tu=23°C, single module

Ordering data

Type of connection

Screw connection

Type

WDS2 RS232/TTY

Qty.

1

Order No.

8615690000

Information

Accessories

Information

Voltage supply 24V and 0V with ZQV 2.5N/2
cross-connection

AD-/DA-Converter

AD-Converter 8-Bit

RS I-D8 0...20mA

RS I-D8 4...20mA



Terminal PIN								Digital volue	Analog voltage
MSB				LSB					
E8	E7	E6	E5	E4	E3	E2	E1		
0	0	0	0	0	0	0	0	0	0 V
0	0	0	0	0	0	0	0		
0	0	0	0	0	0	0	0		
0	0	0	0	0	0	0	0		
-	-	-	-	-	-	-	-		
1	1	1	1	1	1	0	1		
1	1	1	1	1	1	1	0		
1	1	1	1	1	1	1	1		+10 V

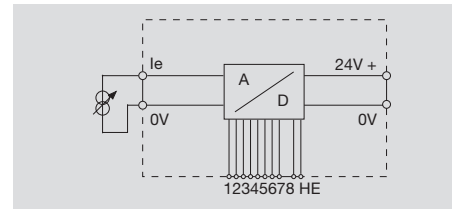
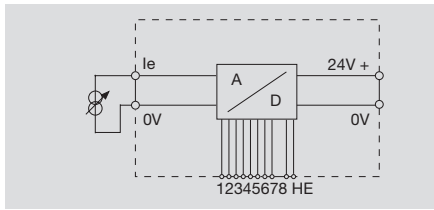

Technical data

Input	
Input voltage/Input current	/0...20 mA
Max. voltage/Max. current	3.5 V/25 mA
Input resistance voltage/Current	/>= 51 Ω
Resolution	78 μA = 1 LSB
Output	
Number of outputs	8Bit (1 Bit sign)
Output level	17 V = H, 0 V = L
Signs	
Output current	<= 25 mA (as source)
Accuracy	+/- 1 LSB
Cut-off freq. (-3dB)	5 kHz at full scale (sinus)
Conversion time	<= 4 μs
General data	
Supply voltage	24 Vdc +/- 20 %
Current consumption	35 mA (plus output current)
Operation temperature	0 °C...+50 °C
Storage temperature	-40 °C...+80 °C
Approvals	CE / ESD
Insulation coordinates	
EMC standards	EMVG, EN 50081-1, EN 50082-2

Input voltage/Input current	/4...20 mA
Max. voltage/Max. current	3.5 V/25 mA
Input resistance voltage/Current	/>= 51 Ω
Resolution	62.5 μA = 1 LSB
Number of outputs	8Bit (1 Bit sign)
Output level	17 V = H, 0 V = L
Signs	
Output current	<= 25 mA (as source)
Accuracy	+/- 1 LSB
Cut-off freq. (-3dB)	5 kHz at full scale (sinus)
Conversion time	<= 4 μs
Supply voltage	24 Vdc +/- 20 %
Current consumption	35 mA (plus output current)
Operation temperature	0 °C...+50 °C
Storage temperature	-40 °C...+80 °C
Approvals	CE
EMC standards	EMVG, EN 50081-1, EN 50082-2

Input voltage/Input current	/4...20 mA
Max. voltage/Max. current	3.5 V/25 mA
Input resistance voltage/Current	/>= 51 Ω
Resolution	62.5 μA = 1 LSB
Number of outputs	8Bit (1 Bit sign)
Output level	17 V = H, 0 V = L
Signs	
Output current	<= 25 mA (as source)
Accuracy	+/- 1 LSB
Cut-off freq. (-3dB)	5 kHz at full scale (sinus)
Conversion time	<= 4 μs
Supply voltage	24 Vdc +/- 20 %
Current consumption	35 mA (plus output current)
Operation temperature	0 °C...+50 °C
Storage temperature	-40 °C...+80 °C
Approvals	CE
EMC standards	EMVG, EN 50081-1, EN 50082-2

Dimensions	
Clamping range (rating- / min. / max.)	mm ²
Length x width x height	mm

Screw connection	
	4 / 0.50 / 4
	70.0 x 35.0 x 72.0

Screw connection	
	4 / 0.50 / 4
	70.0 x 35.0 x 72.0

Ordering data

Type of connection	
Screw connection	

Type	Qty.	Order No.
RS I-D8 0...20MA	1	1160561001

Type	Qty.	Order No.
RS I-D8 4...20MA	1	1168561001

Information

Information

Accessories

Information

Information

AD-/DA-Converter

AD-Converter 8-Bit

RS U-D8 +/-10V

RS U-D8 0...10V



Terminal PIN								Digital value	Analog current
MSB				LSB					
E8	E7	E6	E5	E4	E3	E2	E1		
0	0	0	0	0	0	0	0	0	0 V
0	0	0	0	0	0	0	0		
0	0	0	0	0	0	0	0		
0	0	0	0	0	0	0	0		
-	-	-	-	-	-	-	-		
1	1	1	1	1	1	0	1		
1	1	1	1	1	1	1	0		
1	1	1	1	1	1	1	1		+10 V

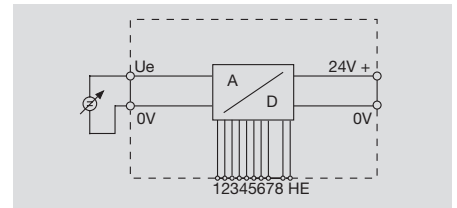
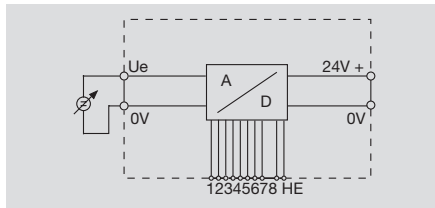

Technical data

Input	
Input voltage/Input current	-10...+10 V/ /<= 55 µA
Max. voltage/Max. current	>= 200 kΩ/ 78 mV = 1 LSB
Input resistance voltage/Current	
Resolution	
Output	
Number of outputs	8Bit (1 Bit sign)
Output level	17 V = H, 0 V = L
Signs	MSB: H = positive; L = negative
Output current	<= 25 mA (as source)
Accuracy	+/- 1 LSB
Cut-off freq. (-3dB)	5 kHz at full scale (sinus)
Conversion time	<= 4 µs
General data	
Supply voltage	24 Vdc +/- 20 %
Current consumption	35 mA (plus output current)
Operation temperature	0 °C...+50 °C
Storage temperature	-40 °C...+80 °C
Approvals	CE / ESD
Insulation coordinates	
EMC standards	EMVG, EN 50081-1, EN 50082-2

Input voltage/Input current	-10...+10 V/ /<= 55 µA
Max. voltage/Max. current	>= 200 kΩ/ 78 mV = 1 LSB
Input resistance voltage/Current	
Resolution	
Output	
Number of outputs	8Bit (1 Bit sign)
Output level	17 V = H, 0 V = L
Signs	MSB: H = positive; L = negative
Output current	<= 25 mA (as source)
Accuracy	+/- 1 LSB
Cut-off freq. (-3dB)	5 kHz at full scale (sinus)
Conversion time	<= 4 µs
General data	
Supply voltage	24 Vdc +/- 20 %
Current consumption	35 mA (plus output current)
Operation temperature	0 °C...+50 °C
Storage temperature	-40 °C...+80 °C
Approvals	CE / ESD
Insulation coordinates	
EMC standards	EMVG, EN 50081-1, EN 50082-2

Input voltage/Input current	0...10 V/ /<= 25 µA
Max. voltage/Max. current	>= 400 kΩ/ 39 mV = 1 LSB
Input resistance voltage/Current	
Resolution	
Output	
Number of outputs	8Bit (1 Bit sign)
Output level	17 V = H, 0 V = L
Signs	
Output current	<= 25 mA (as source)
Accuracy	+/- 1 LSB
Cut-off freq. (-3dB)	5 kHz at full scale (sinus)
Conversion time	<= 4 µs
General data	
Supply voltage	24 Vdc +/- 20 %
Current consumption	35 mA (plus output current)
Operation temperature	0 °C...+50 °C
Storage temperature	-40 °C...+80 °C
Approvals	CE
Insulation coordinates	
EMC standards	EMVG, EN 50081-1, EN 50082-2

Dimensions	
Clamping range (rating- / min. / max.)	mm²
Length x width x height	mm

Screw connection	
	4 / 0.50 / 4
	70.0 x 35.0 x 72.0

Screw connection	
	4 / 0.50 / 4
	70.0 x 35.0 x 72.0

Information	

Ordering data

Type of connection	
Screw connection	

Type	Qty.	Order No.
RS U-D8 +/-10V	1	1122361001

Type	Qty.	Order No.
RS U-D8 0...10V	1	1160361001

Information	

Accessories

Information	

AD-/DA-Converter

DA-Converter 8-Bit

RS D8-I 0...20mA

RS D8-I 4...20mA

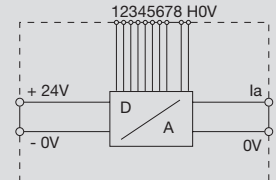
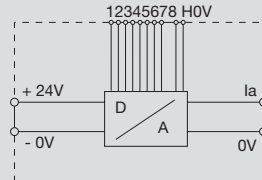

Technical data

Input

Input/Output
Max. voltage
Max. current
Input voltage/Input current
Signs
Resolution

Output

Output voltage/Output current
Offset current/Offset voltage
Load resistance voltage/Current
Accuracy
Conversion time

General data

Supply voltage
Current consumption
Operation temperature
Storage temperature
Approvals

Insulation coordinates

EMC standards

8 Bit / Analogue
max. 30 V

5...24 V/

78 μ A = 1 LSB

/0...20 mA (as source)

max. 0.08 mA/

/ \leq = 600 Ω

+/- 1 LSB

\leq 30 μ s

24 Vdc +/- 20 %

25 mA (plus output current)

0 $^{\circ}$ C...+50 $^{\circ}$ C

-40 $^{\circ}$ C...+80 $^{\circ}$ C

CE / ESD

EMVG, EN 50081-1, EN 50082-2

8 Bit / Analogue
max. 30 V

5...24 V/

62.5 μ A = 1 LSB

/4...20 mA (as source)

4 mA/

/ \leq = 600 Ω

+/- 1 LSB

\leq 30 μ s

24 Vdc +/- 20 %

25 mA (plus output current)

0 $^{\circ}$ C...+50 $^{\circ}$ C

-40 $^{\circ}$ C...+80 $^{\circ}$ C

CE

EMVG, EN 50081-1, EN 50082-2

Dimensions

Clamping range (rating- / min. / max.) mm²
Length x width x height mm

Information

Screw connection

4 / 0.50 / 4
70.0 x 35.0 x 72.0

Screw connection

4 / 0.50 / 4
70.0 x 35.0 x 72.0

Ordering data

Type of connection	
Screw connection	

Type	Qty.	Order No.
RS D8-I 0...20MA	1	1165861001

Type	Qty.	Order No.
RS D8-I 4...20MA	1	1169261001

Information

Accessories

Information

AD-/DA-Converter

DA-Converter 8-Bit

RS D8-U +/-10V

RS D8-U 0...10V

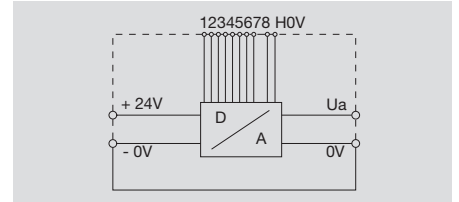
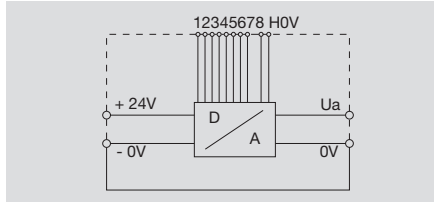

Technical data

Input

Input/Output
Max. voltage
Max. current
Input voltage/Input current
Signs
Resolution

8 Bit / Analogue
max. 30 V
2.5 mA
5...24 V/
MSB: H = positive; L = negative
78 mV = 1 LSB

8 Bit / Analogue
max. 30 V
2.5 mA
5...24 V/
39 mV = 1 LSB

Output

Output voltage/Output current
Offset current/Offset voltage
Load resistance voltage/Current
Accuracy
Conversion time

-10...+10 V/<= 10 mA max. current
/<= 20 mV
>= 1 kΩ/< = 600 Ω
+/- 1 LSB
<= 30 μs

0...10 V/<= 10 mA max. current
/<= 20 mV
>= 1 kΩ/< = 600 Ω
+/- 1 LSB
<= 30 μs

General data

Supply voltage
Current consumption
Operation temperature
Storage temperature
Approvals

24 Vdc +/- 20 %
25 mA (plus output current)
0 °C...+50 °C
-40 °C...+80 °C
CE

24 Vdc +/- 20 %
25 mA (plus output current)
0 °C...+50 °C
-40 °C...+80 °C
CE / ESD

Insulation coordinates

EMC standards

EMVG, EN 50081-1, EN 50082-2

EMVG, EN 50081-1, EN 50082-2

Dimensions

Clamping range (rating- / min. / max.) mm²
Length x width x height mm

Screw connection

4 / 0.50 / 4
70.0 x 35.0 x 72.0

Screw connection

4 / 0.50 / 4
70.0 x 35.0 x 72.0

Information

Ordering data

Type of connection

Screw connection

Type	Qty.	Order No.
RS D8-U +/-10V	1	1123361001

Type	Qty.	Order No.
RS D8-U 0...10V	1	1160761001

Information

Accessories

Information

Articles with coloured order number are kept permanently in stock at the central warehouse in Germany.
Delivery times see page X.2

AD-/DA-Converter

AD-Converter 12-Bit

RS I-D12 0...20mA

RS I-D12 4...20mA

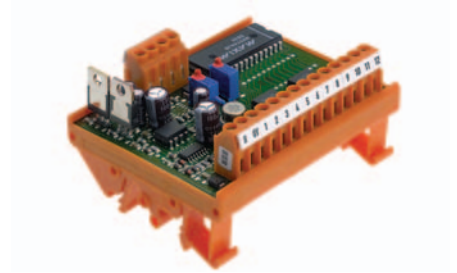

Terminal PIN											
MSB						LSB					
0	0	0	0	0	0	0	0	0	0	0	0
0	0	0	0	0	0	0	0	0	0	0	1
0	0	0	0	0	0	0	0	0	0	0	0
0	0	0	0	0	0	0	0	0	0	0	1
1	1	1	1	1	1	1	1	1	1	1	0
1	1	1	1	1	1	1	1	1	1	1	1
1	1	1	1	1	1	1	1	1	1	1	1

Digital volue
Analog current
4 mA
20 mA

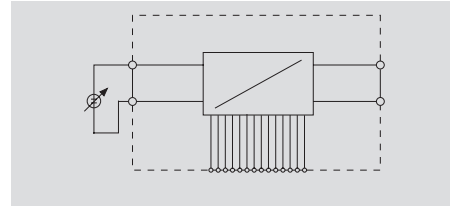
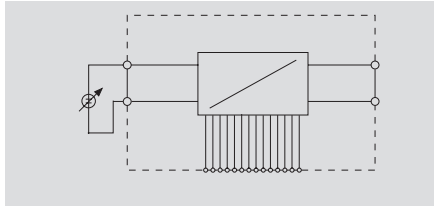

Technical data

Input

Input voltage/Input current
Max. voltage/Max. current
Input resistance voltage/Current
Resolution

/0...20 mA
/30 mA
/500 Ω
4.9 μA = 1 LSB

/4...20 mA
/30 mA
/500 Ω
4 μA = 1 LSB

Output

Number of outputs
Output level
Signs
Output current
Accuracy
Conversion time

12Bit
24 V = H, 0 V = L
≤ 25 mA (as source)
± 1 LSB
≤ 50 μs

12Bit
24 V = H, 0 V = L
≤ 25 mA (as source)
± 1 LSB
≤ 50 μs

General data

Supply voltage
Current consumption
Operation temperature
Storage temperature
Approvals

24 Vdc ± 20 %
0 °C...+50 °C
-40 °C...+80 °C
CE / ESD

24 Vdc ± 20 %
0 °C...+50 °C
-40 °C...+80 °C
CE / ESD

Insulation coordinates

EMC standards

EMVG, EN 50081-1, EN 50082-2

EMVG, EN 50081-1, EN 50082-2

Dimensions

Clamping range (rating- / min. / max.) mm²
Length x width x height mm

Screw connection

4 / 0.50 / 4
70.0 x 90.0 x 47.4

Screw connection

4 / 0.50 / 4
70.0 x 90.0 x 47.4

Information

Ordering data

Type of connection
Screw connection

Type	Qty.	Order No.
RS I-D12 0...20MA	1	1168461001

Type	Qty.	Order No.
RS I-D12 4...20MA	1	1169161001

Information

Accessories

Information

AD-/DA-Converter

AD-Converter 12-Bit

RS U-D12 +/-10V

RS U-D12 0...10V

Terminal PIN											
MSB						LSB					
12	11	10	9	8	7	6	5	4	3	2	1
0	0	0	0	0	0	0	0	0	0	0	0
0	0	0	0	0	0	0	0	0	0	0	1
0	0	0	0	0	0	0	0	0	0	0	1
0	0	0	0	0	0	0	0	0	0	0	1
1	1	1	1	1	1	1	1	1	1	1	0
1	1	1	1	1	1	1	1	1	1	1	0
1	1	1	1	1	1	1	1	1	1	1	1

Digital volue
Analog current
4 mA
20 mA

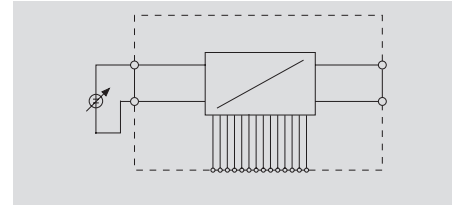
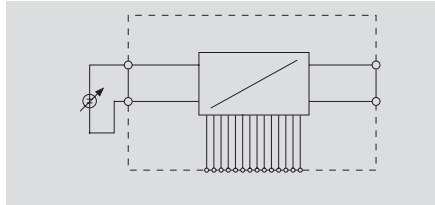

Technical data

Input

Input voltage/Input current
Max. voltage/Max. current
Input resistance voltage/Current
Resolution

-10...+10 V/
+/- 15 V/
100 kΩ/
4.88 mV = 1 LSB

0...10 V/
15 V/
100 kΩ/
2.44 mV = 1 LSB

Output

Number of outputs
Output level
Signs
Output current
Accuracy
Conversion time

12Bit
24 V = H, 0 V = L
MSB: H = positive; L = negative
<= 25 mA (as source)
+/- 1 LSB
<= 50 μs

12Bit
24 V = H, 0 V = L
<= 25 mA (as source)
+/- 1 LSB
<= 50 μs

General data

Supply voltage
Current consumption
Operation temperature
Storage temperature
Approvals

24 Vdc +/- 20 %
0 °C...+50 °C
-40 °C...+80 °C
CE / ESD

24 Vdc +/- 20 %
0 °C...+50 °C
-40 °C...+80 °C
CE / ESD

Insulation coordinates

EMC standards

EMVG, EN 50081-1, EN 50082-2

EMVG, EN 50081-1, EN 50082-2

Dimensions

Clamping range (rating- / min. / max.) mm²
Length x width x height mm

Screw connection

4 / 0.50 / 4
70.0 x 90.0 x 47.4

Screw connection

4 / 0.50 / 4
70.0 x 90.0 x 47.4

Information

Ordering data

Type of connection	
Screw connection	

Type	Qty.	Order No.
RS U-D12 +/-10V	1	1168261001

Type	Qty.	Order No.
RS U-D12 0...10V	1	1168361001

Information

Accessories

Information

AD-/DA-Converter

DA-Converter 12-Bit

RS D12-I 0...20mA

RS D12-I 4...20mA

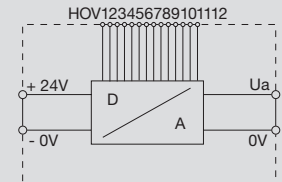
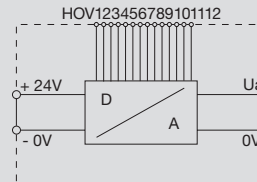
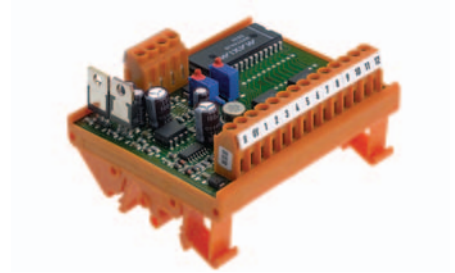

Technical data

Input

Input/Output
Max. voltage
Max. current
Input voltage/Input current
Signs
Resolution

Output

Output voltage/Output current
Offset current/Offset voltage
Load resistance voltage/Current
Accuracy
Conversion time

General data

Supply voltage
Current consumption
Operation temperature
Storage temperature
Approvals

Insulation coordinates

EMC standards

12 Bit / analogue

24 Vdc +/- 20 %/4.2 mA

4.9 μ A = 1 LSB

/0...20 mA (as source)

/

< = 600 Ω

+/- 1 LSB

<= 4 μ s

24 Vdc +/- 20 %

60 mA

0 $^{\circ}$ C...+50 $^{\circ}$ C

-40 $^{\circ}$ C...+80 $^{\circ}$ C

CE / ESD

EMVG, EN 50081-1, EN 50082-2

12 Bit / analogue

24 Vdc +/- 20 %/4.2 mA

4 μ A = 1 LSB

/4...20 mA (as source)

/

< = 600 Ω

+/- 1 LSB

<= 4 μ s

24 Vdc +/- 20 %

60 mA

0 $^{\circ}$ C...+50 $^{\circ}$ C

-40 $^{\circ}$ C...+80 $^{\circ}$ C

CE / ESD

EMVG, EN 50081-1, EN 50082-2

Dimensions

Clamping range (rating- / min. / max.) mm²
Length x width x height mm

Information

Screw connection

4 / 0.50 / 4
70.0 x 90.0 x 47.4

Screw connection

4 / 0.50 / 4
70.0 x 90.0 x 47.4

Ordering data

Type of connection
Screw connection

Type	Qty.	Order No.
RS D12-I 0...20MA	1	1166061001

Type	Qty.	Order No.
RS D12-I 4...20MA	1	1165961001

Information

Accessories

Information

AD-/DA-Converter

DA-Converter 12-Bit

RS D12-U +/-10V

RS D12-U 0...10V

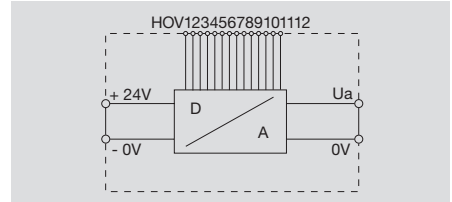
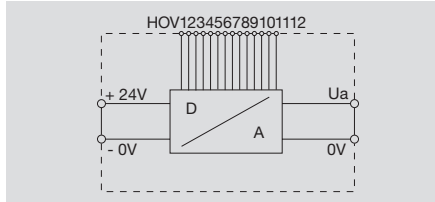
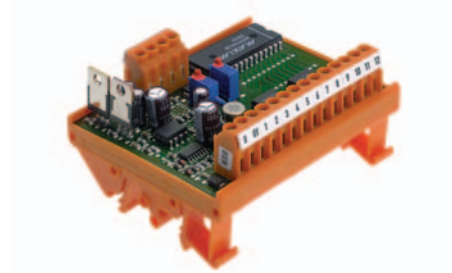

Technical data

Input

Input/Output
Max. voltage
Max. current
Input voltage/Input current
Signs
Resolution

12 Bit / analogue

24 Vdc +/- 20 %/4.2 mA
MSB: H = positive; L = negative
4.88 mV = 1 LSB

12 Bit / analogue

24 Vdc +/- 20 %/4.2 mA
2.44 mV = 1 LSB

Output

Output voltage/Output current
Offset current/Offset voltage
Load resistance voltage/Current
Accuracy
Conversion time

-10...+10 V/<= 10 mA
/
>= 1 kΩ/< = 600 Ω
+/- 1 LSB
<= 4 μs

0...10 V/<= 10 mA
/
>= 1 kΩ/< = 600 Ω
+/- 1 LSB
<= 4 μs

General data

Supply voltage
Current consumption
Operation temperature
Storage temperature
Approvals

24 Vdc +/- 20 %
40 mA
0 °C...+50 °C
-40 °C...+80 °C
CE / ESD

24 Vdc +/- 20 %
40 mA
0 °C...+50 °C
-40 °C...+80 °C
CE / ESD

Insulation coordinates

EMC standards

EMVG, EN 50081-1, EN 50082-2

EMVG, EN 50081-1, EN 50082-2

Dimensions

Clamping range (rating- / min. / max.) mm²
Length x width x height mm

Screw connection

4 / 0.50 / 4
70.0 x 90.0 x 47.4

Screw connection

4 / 0.50 / 4
70.0 x 90.0 x 47.4

Information

Ordering data

Type of connection

Screw connection

Type	Qty.	Order No.
RS D12-U +/-10V	1	1160861001

Type	Qty.	Order No.
RS D12-U 0...10V	1	1166161001

Information

Accessories

Information

Articles with coloured order number are kept permanently in stock at the central warehouse in Germany.
Delivery times see page X.2

Preprocessing logic

Preprocessing logic

- Logic function and time function can be combined
- Individually programmable (further functions on request)

DKPL

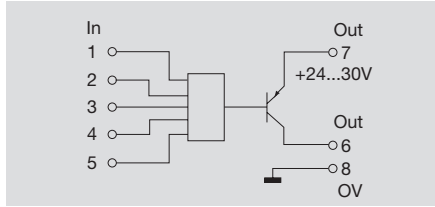
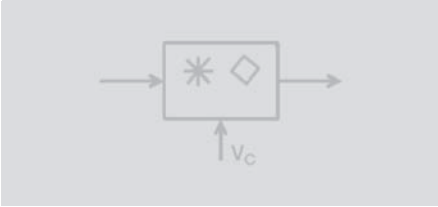
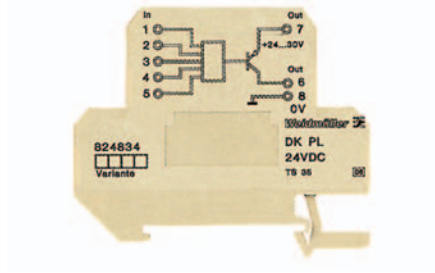

Technical data

Input

Rated input level/
Input current
Max. voltage
Pulse duration/

24 Vdc = high, 0 V = low/
approx. 1.5 mA each input (24V)
30 Vdc
> 1 ms/

Output

Output level/
Output current/
Switching thresholds/

PNP, Ub-1 V/
max. 20 mA/
high > 18 V, low < 7 V/

General data

Supply voltage
Current consumption
Operation temperature
Storage temperature
Approvals

24 Vdc +/- 20 %
< 10 mA
0 °C...+50 °C
-40 °C...+60 °C
CE / ESD

Dimensions

Clamping range (rating- / min. / max.) mm²
Length x width x height mm

Screw connection

4 / 0.50 / 4
65.0 x 6.0 x 57.0

Information

Ordering data

Type of connection

Screw connection

Type

DKPL 35 24VDC

Qty.

5

Order No.

8248340000

Information

not programmed - functions see following page

Accessories

Information

Remarks:

The module is programmed specifically to customer requirements. Up to 5 inputs can be linked with various logic and time functions, e.g. AND, OR, EXOR, NAND, NOR, EXNOR, delay links, etc.
The output is either low- or high-active.

824834 0001 DKPL

A = (E1 OR E2) AND (E3 OR E4) AND E5

Status	Input					Output
	5	4	3	2	1	6
1	0	0	0	0	0	0
2	0	0	0	0	1	0
3	0	0	0	1	0	0
4	0	0	0	1	1	0
5	0	0	1	0	0	0
6	0	0	1	0	1	0
7	0	0	1	1	0	0
8	0	0	1	1	1	0
9	0	1	0	0	0	0
10	0	1	0	0	1	0
11	0	1	0	1	0	0
12	0	1	0	1	1	0
13	0	1	1	0	0	0
14	0	1	1	0	1	0
15	0	1	1	1	0	0
16	0	1	1	1	1	0
17	1	0	0	0	0	0
18	1	0	0	0	1	0
19	1	0	0	1	0	0
20	1	0	0	1	1	0
21	1	0	1	0	0	0
22	1	0	1	0	1	1
23	1	0	1	1	0	1
24	1	0	1	1	1	1
25	1	1	0	0	0	0
26	1	1	0	0	1	1
27	1	1	0	1	0	1
28	1	1	0	1	1	1
29	1	1	1	0	0	0
30	1	1	1	0	1	1
31	1	1	1	1	0	1
32	1	1	1	1	1	1

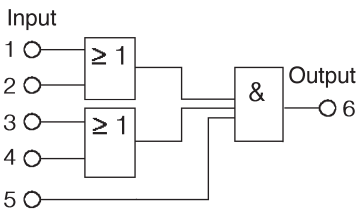

824834 0002 DKPL

Inputs 1 and 2 have the function of an RS FLIP-FLOP
Inputs 3, 4 and 5 have no function

Input	2	1	Output	6
0	0		0	(is saved)
0	1		no change	to the saved status
1	0		no change	to the saved status
1	1		1	(is saved)
Inputs 3, 4 and 5			no change	to the saved status

Inputs 3, 4 and 5 with-out function

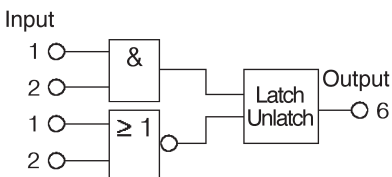

824834 0003 DKPL Frequency divider

Inputs 1 - 5 determine the division factor
Input 1 = division factor 1: $F_{OUT} = F_{IN} \cdot 1$
Input 2 = division factor 2: $F_{OUT} = F_{IN} \cdot 2$
Input 5 = division factor 5: $F_{OUT} = F_{IN} \cdot 5$; $F_{IN} \text{ max.} = 12 \text{ kHz}$

Input	Output
	6
1	$f_{out} = f_{in}$
2	$f_{out} = f_{in} / 2$
3	$f_{out} = f_{in} / 3$
4	$f_{out} = f_{in} / 4$
5	$f_{out} = f_{in} / 5$

Remarks: a new division factor can only be used after the operating voltage has been switched off. $f_{in} \text{ max.} = 12 \text{ kHz}$

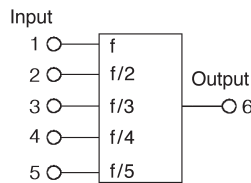

824834 0004 DKPL

Input 1: signal A from an incremental transducer
Input 2: signal B90 offset
Input 3: enable high active
Input 4: output signal inverted high active
Input 5: no function
Output: the output is set for 20 - 30 μ s at every edge of signal A or B
(i.e.: $F_{OUT} = 4 \times F_{IN}$)
 $F_{IN} \text{ max.} = 1 \text{ kHz}$

Connection	Description
1	A Signal A 90° leading $F_{max} = 1 \text{ kHz}$
2	B Signal B 90° trailing $F_{max} = 1 \text{ kHz}$
3	enable enable output
4	invert invert output signal
5	no function
6	$f_{out} = 4 \times f_{A/B} \text{ (max. } 4 \text{ kHz)}$

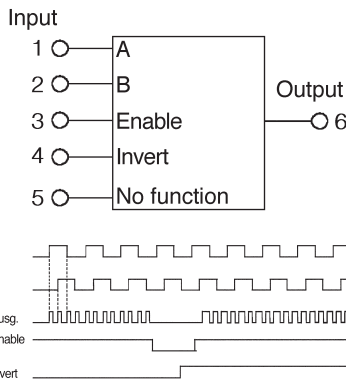

824834 0005 DKPL

Input pulse length between 80 and 100 ms
Output pulse length 100 ms, only 2 pulses
Pulse/pause ratio 1:1.
The positive edge of the input signal must be evaluated.
Only input E1 is used.

824834 0006 DKPL

Input 1: $F_{OUT} = F_{IN} \cdot 10$
Input 2: $F_{OUT} = F_{IN} \cdot 10$

Input	Output
	6
1	$f_{out} = f_{in}$
2	$f_{out} = f_{in} / 10$
3	$f_{out} = f_{in} / 50$
4	$f_{out} = f_{in} / 100$
5	$f_{out} = f_{in} / 1000$

Remarks: a new division factor can only be used after the operating voltage has been switched off. $f_{in} \text{ max.} = 3 \text{ kHz}$

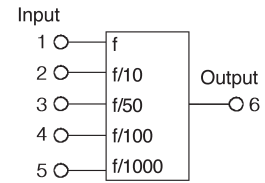

824834 0007 DKPL

Input	Output				
1	2	3	4	5	Out
L	L	X	X	X	no function
H	L	X	X	X	$f = 1 \text{ Hz}$
L	H	X	X	X	$f = 10 \text{ Hz}$
H	H	X	X	X	$f = 1 \text{ Hz}$

L -> 0 V or connection open
H -> +24 ...30 Vdc
X -> no influence on the output function, L or H

824834 0008 DKPL

Input	Output	
1	2	Output
H	H	H
L	H	L

824834 0010 DKPL

RS FLIP-FLOP with superimposed S-input (connection 2)
Inputs connections 3, 4 and 5 must be at 0V or remain open!

Connection1 logic	Connection2 logic	Connection6 logic		
R-input	S-input	Output		
0 V or open	L	0 V or open	L	previous status is saved
+24 Vdc	H	0 V or open	L	0 V
0 V or open	L	+24 Vdc	H	+24 Vdc
+24 Vdc	H	+24 Vdc	H	+24 Vdc

824834 0501 DKPL

The component allows for division of the input frequency at connection 1 (0 .. max. 50 kHz) with 2 fixed division factors. Depending on connection 2, the output frequency is issued at the output connection 6.
Connections 3, 4 and 5 have no function

Connection2 logic	Factor	Input frequency	Output frequency	
Connection 1	Connection 2	Connection 1	Connection 2	
0 V or open	L	75	0...30 kHz	0...400 Hz
24 Vdc	H	27	0...10.8 kHz	0...400 Hz

Preprocessing logic

Preprocessing logic

- Logic functions
- Compact design
- PLC load reduction

AND

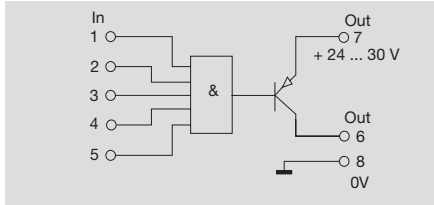
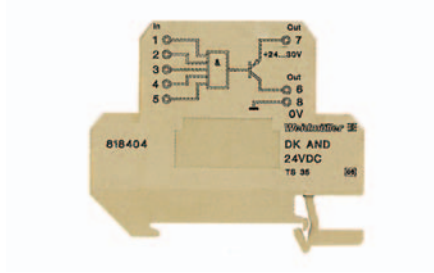

Technical data

Input

Rated input level/
Input current
Max. voltage
Pulse duration/

24 Vdc = high, 0 V = low/
approx. 1.5 mA each input (24V)
30 Vdc
> 50 µs/

Output

Output level/
Output current/
Switching thresholds/

PNP, $U_b - 1.8$ V/
max. 20 mA/
high < 15 V, low < 9 V/

General data

Supply voltage
Current consumption
Operation temperature
Storage temperature
Approvals

24...30 Vdc
< 5 mA
0 °C...+50 °C
-40 °C...+60 °C
CE / ESD

Dimensions

Clamping range (rating- / min. / max.) mm²
Length x width x height mm

Screw connection

4 / 0.50 / 4
65.0 x 6.0 x 57.0

Information

Ordering data

Type of connection

Screw connection

Type

DK AND 35 24VDC

Qty.

5

Order No.

8184040000

Information

Accessories

Information

Preprocessing logic

Preprocessing logic

- Logic functions
- Compact design
- PLC load reduction

NAND

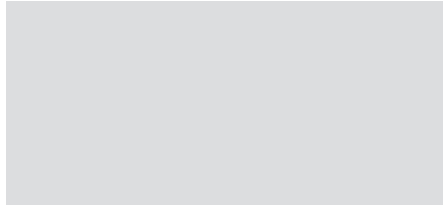
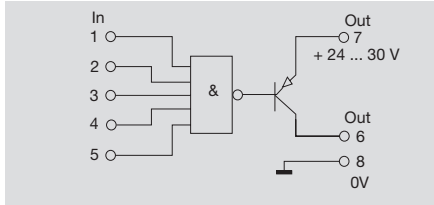
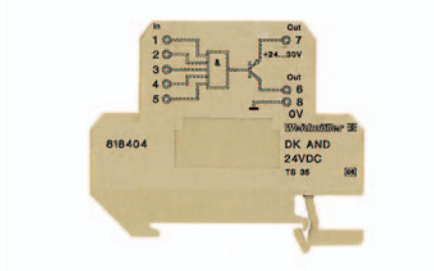

Technical data

Input

Rated input level/
Input current
Max. voltage
Pulse duration/

24 Vdc = high, 0 V = low/
approx. 1.5 mA each input (24V)
30 Vdc
> 50 µs/

Output

Output level/
Output current/
Switching thresholds/

PNP, $U_b - 1.8$ V/
max. 20 mA/
high < 15 V, low < 9 V/

General data

Supply voltage
Current consumption
Operation temperature
Storage temperature
Approvals

24...30 Vdc
< 5 mA
0 °C...+50 °C
-40 °C...+60 °C
CE / ESD

Dimensions

Clamping range (rating- / min. / max.) mm²
Length x width x height mm

Screw connection

4 / 0.50 / 4
65.0 x 6.0 x 57.0

Information

Ordering data

Type of connection

Screw connection

Type

DK NAND 35 24VDC

Qty.

5

Order No.

8248320000

Information

Accessories

Information

Articles with coloured order number are kept permanently in stock at the central warehouse in Germany.
Delivery times see page X.2

Preprocessing logic

Preprocessing logic

- Logic functions
- Compact design
- PLC load reduction

OR

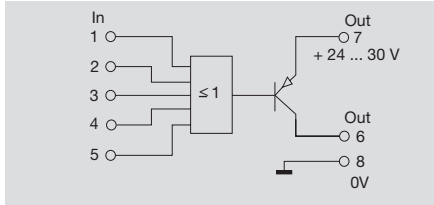
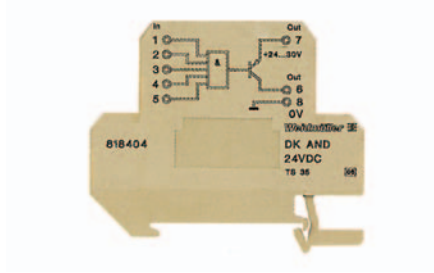

Technical data

Input

Rated input level/
Input current
Max. voltage
Pulse duration/

24 Vdc = high, 0 V = low/
approx. 1.5 mA each input (24V)
30 Vdc
> 50 µs/

Output

Output level/
Output current/
Switching thresholds/

PNP, U_b -1.8 V/
max. 20 mA/
high <15 V, low < 9 V/

General data

Supply voltage
Current consumption
Operation temperature
Storage temperature
Approvals

24...30 Vdc
< 5 mA
0 °C...+50 °C
-40 °C...+60 °C
CE / ESD

Dimensions

Clamping range (rating- / min. / max.) mm²
Length x width x height mm

Screw connection

4 / 0.50 / 4
65.0 x 6.0 x 57.0

Information

Ordering data

Type of connection

Screw connection

Type

DK OR 35 24VDC

Qty.

5

Order No.

8218440000

Information

Accessories

Information

Preprocessing logic

Preprocessing logic

- Logic functions
- Compact design
- PLC load reduction

NOR

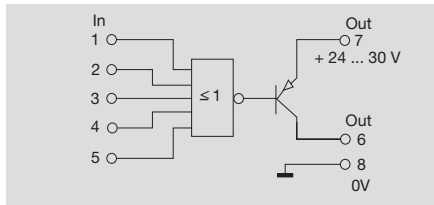
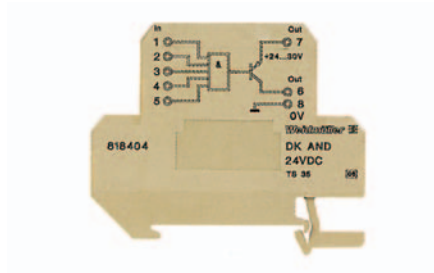

Technical data

Input

Rated input level/
Input current
Max. voltage
Pulse duration/

24 Vdc = high, 0 V = low/
approx. 1.5 mA each input (24V)
30 Vdc
> 50 µs/

Output

Output level/
Output current/
Switching thresholds/

PNP, U_b -1.8 V/
max. 20 mA/
high <15 V, low < 9 V/

General data

Supply voltage
Current consumption
Operation temperature
Storage temperature
Approvals

24...30 Vdc
< 5 mA
0 °C...+50 °C
-40 °C...+60 °C
CE / ESD

Dimensions

Clamping range (rating- / min. / max.) mm²
Length x width x height mm

Screw connection

4 / 0.50 / 4
65.0 x 6.0 x 57.0

Information

Ordering data

Type of connection

Screw connection

Type

DK NOR 35 24VDC

Qty.

5

Order No.

8248330000

Information

Accessories

Information

Monitoring modules

Current and voltage monitoring

The monitoring of current and voltage allows constant control of individual systems or installation parts. Deviations or interruptions occurring in the electric circuits can be evaluated as operation interruptions. Specific measures can be taken to remedy the problem.

Products for monitoring current convert sinus or non-sinus ac and dc current up to 60 A into analogue standard signals. The measuring procedures are based on two principles. On the one hand, ac current up to 10 A and 50/60 Hz are measured using the **transforming method**. The module is looped directly into the measuring circuit. From 10 A ac/dc, the **Hall sensor** is used.

The conductor is pushed through the module free of potential and allows current measurements up to 60 A ac/dc. Often there are high-frequency signal parts on the line being measured. To take account of the signal parts, so-called **TRMS converters (true root mean square)** are connected up in series. They allow measurements up to 2 kHz regardless of the curve shape. Available outputs are standard signals 0..20 mA, 4..20 mA, 4 ..20 mA current loop feed, 0..10 V or a switch output.

Modules for voltage monitoring measure the mains voltage up to max. 450 V ac. The unit provides isolated qualitative information in the form of a standard signal (0..20 mA, 4..20 mA, 0..10 V). Extreme loads or load relief on the power supply can cause short-term voltage fluctuations with a negative influence on the process. The **WAVECONTROL** module VMA transmits the relevant information to the control so that suitable process safety measures can be taken.

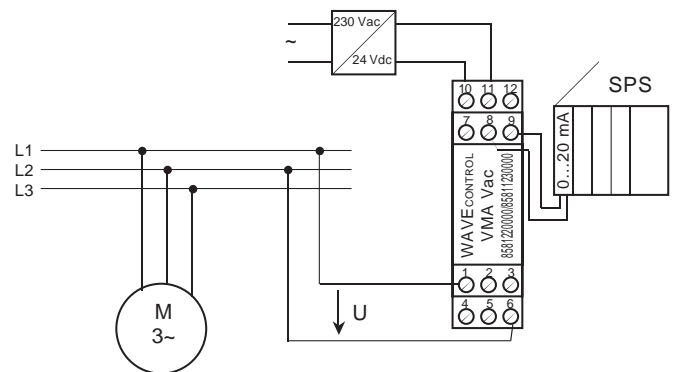
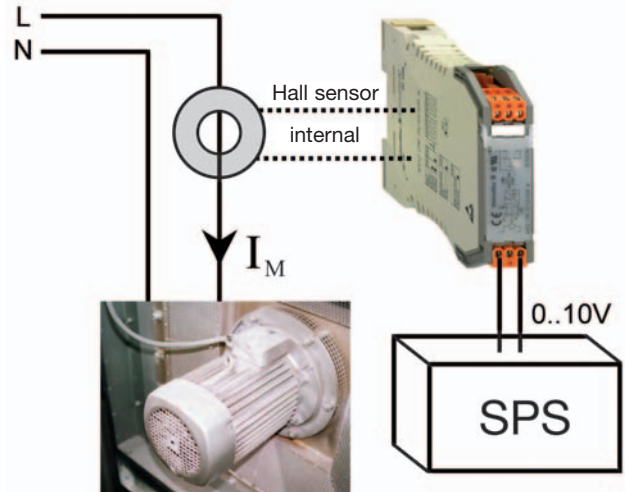

Current monitoring

Relay output

- Current range adjustable via DIP-switch
- Switchable hysteresis
- Operating current or closed current principle

1/5/10A ac



20/40/60A ac

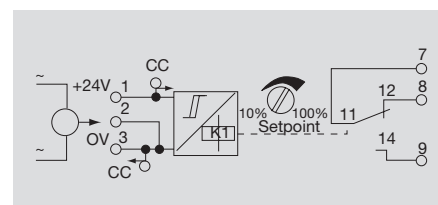
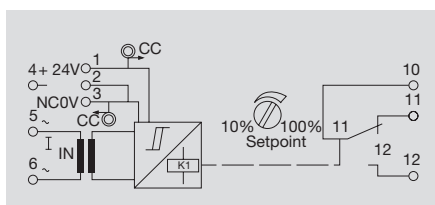
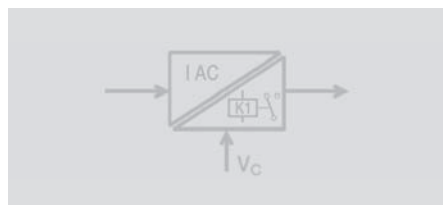

Technical data

Input	1/5/10A ac	20/40/60A ac
Input current	0...1 Aac/ 0...5 Aac/ 0...10 Aac	0...20 Aac/ 0...40 Aac/ 0...60 Aac
Input frequency	50...60 Hz	50...60 Hz
Max. current	100 A for 1s	dependent on conductor cross-section
Max. voltage	250 Vac	400 Vac, > 400V ac depends on wire insulation
Sensor	Transforming (internally)	hall sensor (internal)
Diameter of bushing		8 mm
Output		
Switching thresholds	10...100 % by front poten.	10...100 % by front poten.
Hysteresis	5 % or 10 % of threshold value	5 % or 10 % of threshold value
Switching voltage max./Switching voltage min.	60 Vdc/ 250 Vac/6 Vdc/ac	60 Vdc/ 250 Vac/6 Vdc/ac
Switching current max./Switching current min.	7 A/100 mA	7 A/100 mA
Step response time	typ. 700 ms	typ. 700 ms
Temperature coefficient	<= 800 ppm/K	<= 250 ppm/K
Status indicator	LED green	LED green
General data		
Supply voltage	24 Vdc +/- 10 %	24 Vdc +/- 10 %
Current consumption	8.3 mA (Relay not triggered)/ 24 mA (Relay triggered)	23 mA (Relay not triggered)/ 47 mA (Relay triggered)
Current-carrying cap. of cross-connect.	<= 2 A	<= 2 A
Operation temperature	0 °C...+50 °C	0 °C...+50 °C
Storage temperature	-20 °C...+70 °C	-20 °C...+70 °C
Default settings	0...5A / 10% Hysteresis / current principle	0...40A / 10% Hysteresis / current principle
Approvals	CE / ESD / cURus	CE / ESD / cURus
Contact arrangement	1 changeover contact	1 changeover contact
Insulation coordinates		
Rated voltage	300 V	300 V
Impulse withstand voltage	4 kV	4 kV
Pollution severity	2	2
Overtoltage category	III	III
Clearance & creepage path	>= 3 mm	>= 3 mm
Isolation voltage Input, output	4 kVeff / 5s	4 kVeff / 5s

Dimensions	Screw connection	Tension clamp c.	Screw connection	Tension clamp c.
Clamping range (rating- / min. / max.)	2.50 / 0.50 / 2.50	1.50 / 0.50 / 2.50	2.50 / 0.50 / 2.50	1.50 / 0.50 / 2.50
Length x width x height	92.4 x 22.5 x 112.4	92.4 x 22.5 x 112.4	92.4 x 22.5 x 112.4	92.4 x 22.5 x 112.4
Information	Tu=23°C, single module		Tu=23°C, single module	

Ordering data

Type of connection	Type	Qty.	Order No.	Type	Qty.	Order No.
Screw connection Tension clamp c.	WAS2 CMR 1/5/10A ac	1	8516560000	WAS2 CMR 20/40/60A ac	1	8513340000
	WAZ2 CMR 1/5/10A ac	1	8516570000	WAZ2 CMR 20/40/60A ac	1	8526600000
Information	Voltage supply 24V and 0V with ZQV 2.5N/2 cross-connection			Voltage supply 24V and 0V with ZQV 2.5N/2 cross-connection		

Accessories

Information

Current monitoring

Analogue output

- Input and output adjustable via DIP-switch
- Calibration not necessary

1/5/10A ac



1/5/10A ac 4...20mA

Current loop

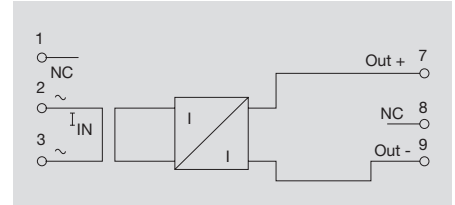
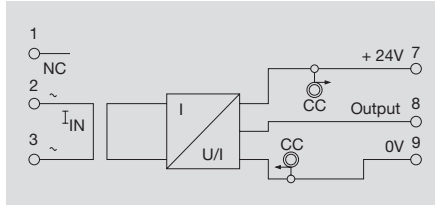
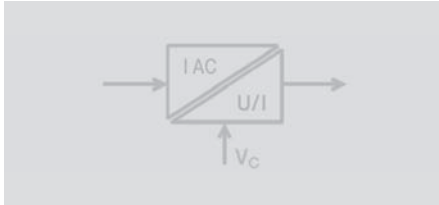

Technical data

Input

Input current	0...1 Aac/ 0...5 Aac/ 0...10 Aac
Input frequency	50...60 Hz
Max. current	100 A for 1s
Voltage of measuring circuit	250 Vac
Sensor	Transforming (internally)
Diameter of bushing	

Output

Output current/Output voltage	0(4)...20 mA/0...10 V
Offset current	max. 100 µA
Output signal limit	approx. 13 V resp. 24 mA
Load resistance voltage/Current	>= 1 kΩ / < = 600 Ω
Step response time	typ. 700 ms
Accuracy	0.5% FSR
Temperature coefficient	<= 200 ppm/K
Status indicator	LED ON: OK; FLASHING: signal out of range; OFF: Error

General data

Supply voltage	24 Vdc +/- 10%
Current consumption	40 mA at I _{out} =20 mA
Current-carrying cap. of cross-connect.	<= 2 A
Operation temperature/Storage temperature	0 °C...+50 °C/-20 °C...+70 °C
Default settings	0...5Aac, 4...20mA
Approvals	CE / ESD / cURus

Insulation coordinates

Rated voltage	300 V
Impulse withstand voltage	6 kV
Pollution severity	2
Overvoltage category	III
Clearance & creepage path	>= 5.5 mm
Isolation voltage Input, output	4 kVeff / 5s

Dimensions

Clamping range (rating- / min. / max.)	mm ²
Length x width x height	mm

Information

Screw connection

2.50 / 0.50 / 2.50	1.50 / 0.50 / 2.50
72.0 x 22.5 x 92.4	72.0 x 22.5 x 92.4

Tension clamp c.

T_u=23°C, single module

Screw connection

2.50 / 0.50 / 2.50	1.50 / 0.50 / 2.50
72.0 x 22.5 x 92.4	72.0 x 22.5 x 92.4

Tension clamp c.

T_u=23°C, single module

Ordering data

Type of connection

Screw connection
Tension clamp c.

Type	Qty.	Order No.
WAS1 CMA 1/5/10A ac	1	8523400000
WAZ1 CMA 1/5/10A ac	1	8523410000

Type	Qty.	Order No.
WAS1 CMA LP 1/5/10A ac	1	8528650000
WAZ1 CMA LP 1/5/10A ac	1	8528660000

Information

Accessories

Information

Voltage supply 24V and 0V with ZQV 2.5N/2 cross-connection

Current monitoring

Analogue output

- Input and output adjustable via DIP-switch
- Calibration not necessary

5/10A ac/dc



20/25/30A ac/dc

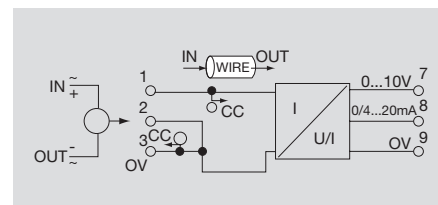
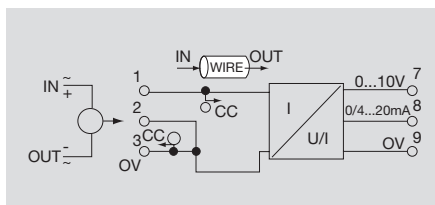
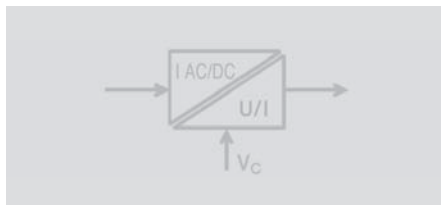

Technical data

Input

Input current
Input frequency
Max. current
Voltage of measuring circuit
Sensor
Diameter of bushing

0...5 Aac/dc/ 0...10 Aac/dc
0...2 kHz (true RMS to DC converter)
dependent on conductor cross-section
400 Vac, >400V ac depends on conductor insulation
hall sensor (internal)
8 mm

0...20 Aac/dc/0...25 Aac/dc / 0...30 Aac/dc
0...2 kHz (true RMS to DC converter)
dependent on conductor cross-section
400 Vac, >400V ac depends on conductor insulation
hall sensor (internal)
8 mm

Output

Output current/Output voltage
Offset current
Output signal limit
Load resistance voltage/Current
Step response time
Accuracy
Temperature coefficient
Status indicator

0(4)...20 mA/0...10 V
max. 150 μ A
approx. 13 V resp. 24 mA
 $\geq 1 \text{ k}\Omega / < = 600 \Omega$
typ. 700 ms
0.5% FSR
 $\leq 650 \text{ ppm/K}$
LED ON: OK; FLASHING: signal out of range; OFF: Error

0(4)...20 mA/0...10 V
max. 150 μ A
approx. 13 V resp. 24 mA
 $\geq 1 \text{ k}\Omega / < = 600 \Omega$
typ. 700 ms
0.5% FSR
 $\leq 650 \text{ ppm/K}$
LED ON: OK; FLASHING: signal out of range; OFF: Error

General data

Supply voltage
Current consumption
Current-carrying cap. of cross-connect.
Operation temperature/Storage temperature
Default settings
Approvals

24 Vdc +/- 10 %
50 mA at Iout=20 mA
 $\leq 2 \text{ A}$
0 °C...+50 °C/-20 °C...+70 °C
0...5A, 4...20mA
CE / ESD / cURus

24 Vdc +/- 10 %
50 mA at Iout=20 mA
 $\leq 2 \text{ A}$
0 °C...+50 °C/-20 °C...+70 °C
0...25A, 4...20mA
CE / ESD / cURus

Insulation coordinates

Rated voltage
Impulse withstand voltage
Pollution severity
Overvoltage category
Clearance & creepage path
Isolation voltage Input, output

300 V
6 kV
2
III
 $\geq 5.5 \text{ mm}$
4 kVeff / 5s

300 V
6 kV
2
III
 $\geq 5.5 \text{ mm}$
4 kVeff / 5s

Dimensions

Clamping range (rating- / min. / max.) mm²
Length x width x height mm

Screw connection

2.50 / 0.50 / 2.50
92.4 x 22.5 x 112.4

Tension clamp c.

1.50 / 0.50 / 2.50
92.4 x 22.5 x 112.4

Screw connection

2.50 / 0.50 / 2.50
92.4 x 22.5 x 112.4

Tension clamp c.

1.50 / 0.50 / 2.50
92.4 x 22.5 x 112.4

Information

Tu=23°C, single module

Tu=23°C, single module

Ordering data

Type of connection

Screw connection
Tension clamp c.

Type	Qty.	Order No.
WAS2 CMA 5/10A uc	1	8526610000
WAZ2 CMA 5/10A uc	1	8526620000

Type	Qty.	Order No.
WAS2 CMA 20/25/30A uc	1	8545830000
WAZ2 CMA 20/25/30A uc	1	8545840000

Information

Accessories

Information

Voltage supply 24V and 0V with ZQV 2.5N/2 cross-connection

Voltage supply 24V and 0V with ZQV 2.5N/2 cross-connection

Current monitoring

Analogue output

- Input and output adjustable via DIP-switch
- Calibration not necessary

40/50/60A ac/dc

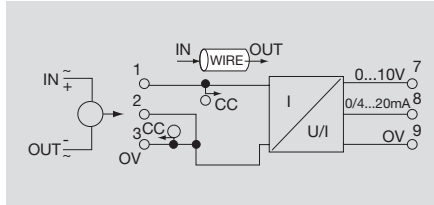
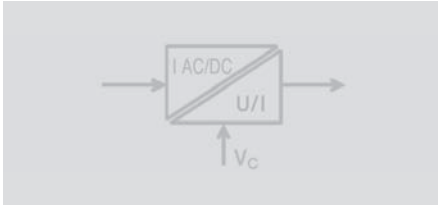

Technical data

Input

Input current
Input frequency
Max. current
Voltage of measuring circuit
Sensor
Diameter of bushing

0...40 Aac/dc/ 0...50 Aac/dc/ 0...60 Aac/dc
0...2 kHz (true RMS to DC converter)
dependent on conductor cross-section
400 Vac, >400V ac depends on conductor insulation
hall sensor (internal)
8 mm

Output

Output current/Output voltage
Offset current
Output signal limit
Load resistance voltage/Current
Step response time
Accuracy
Temperature coefficient
Status indicator

0(4)...20 mA/0...10 V
max. 150 μ A
approx. 13 V resp. 24 mA
 $\geq 1 \text{ k}\Omega / < 600 \Omega$
typ. 700 ms
0.5% FSR
 $\leq 650 \text{ ppm/K}$
LED ON: OK; FLASHING: signal out of range; OFF: Error

General data

Supply voltage
Current consumption
Current-carrying cap. of cross-connect.
Operation temperature/Storage temperature
Default settings
Approvals

24 Vdc +/- 10 %
50 mA at $I_{out}=20 \text{ mA}$
 $\leq 2 \text{ A}$
0 °C...+50 °C/-20 °C...+70 °C
0...50A, 4...20mA
CE / ESD / cURus

Insulation coordinates

Rated voltage
Impulse withstand voltage
Pollution severity
Overvoltage category
Clearance & creepage path
Isolation voltage Input, output

300 V
6 kV
2
III
 $\geq 5.5 \text{ mm}$
4 kVeff / 5s

Dimensions

Clamping range (rating- / min. / max.) mm²
Length x width x height mm

Screw connection

2.50 / 0.50 / 2.50
92.4 x 22.5 x 112.4

Tension clamp c.

1.50 / 0.50 / 2.50
92.4 x 22.5 x 112.4

Information

Tu=23°C, single module

Ordering data

Type of connection

Screw connection
Tension clamp c.

Type

WAS2 CMA 40/50/60A uc
WAZ2 CMA 40/50/60A uc

Qty.

1
1

Order No.

8513330000
8526590000

Information

Accessories

Information

Voltage supply 24V and 0V with ZQV 2.5N/2 cross-connection

Current monitoring

Analogue output

- Max. conductor diameter 35mm
- Can be added sidewise
- Mounting on mounting-rail TS35

CMA 100/5A



CMA 250/5A



CMA 500/5A



Technical data

Input

Input current
Input frequency
Max. current
Voltage of measuring circuit
Diameter of bushing

Output

Output current
Load resistance voltage/Current
Accuracy

General data

Operation temperature/Storage temperature
Approvals

Insulation coordinates

Isolation voltage Input, output

100 Aac
Class 1: 50...60Hz / Class 1.5: 16...400Hz
thermal current I_{th} >3 kA
600 V eff (unfinished conductor)
35 mm

5 Aac
/ < = 600 Ω
class 1 / 1.5; residual current factor < 5

-5 °C...+40 °C/-40 °C...+85 °C
CE / cURus

4 kVeff / 1 min.

250 Aac
Class 1: 50...60Hz / Class 1.5: 16...400Hz
thermal current I_{th} >3 kA
600 V eff (unfinished conductor)
35 mm

5 Aac
/ < = 600 Ω
class 1 / 1.5; residual current factor < 5

-5 °C...+40 °C/-40 °C...+85 °C
CE / cURus

4 kVeff / 1 min.

500 Aac
Class 1: 50...60 Hz / Class 1.5: 16...400 Hz
thermal current I_{th} >3 kA
600 V eff (unfinished conductor)
35 mm

5 Aac
/ < = 600 Ω
class 1 / 1.5; residual current factor < 5

-5 °C...+40 °C/-40 °C...+85 °C
CE / cURus

4 kVeff / 1 min.

Dimensions

Clamping range (rating- / min. / max.) mm²
Length x width x height mm

Information

Screw connection (secondary)

50.0 x 78.0 x 90.5

Screw connection (secondary)

50.0 x 78.0 x 90.5

Screw connection (secondary)

50.0 x 78.0 x 90.5

Ordering data

Type of connection

Screw connection (secondary)

Type	(Qty.=1)	Order No.
CMA 100/5A		8662140000

Type	(Qty.=1)	Order No.
CMA 250/5A		8664570000

Type	(Qty.=1)	Order No.
CMA 500/5A		8664580000

Information

Accessories

Information

Voltage monitoring

Analogue output

- 3-way disconnection
- Max. measuring-voltage 450 V_{ac}eff
- Output selectable via DIP-switch
- Calibration not necessary

VMA Vac

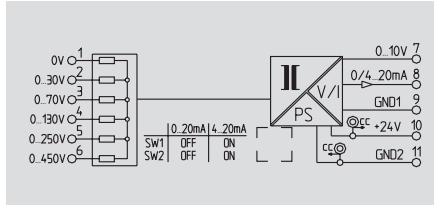
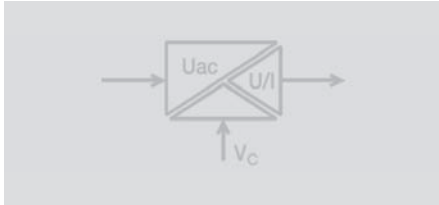

Application

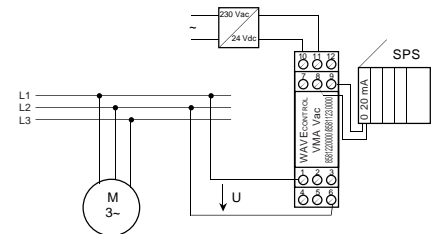

Technical data

Input

Input voltage
Input frequency
Input voltage
Max. voltage

0...30Vac/ 0...70Vac/ 0...130Vac/ 0...250Vac/ 0...450Vac
40...40 Hz sinus
0...30Vac/ 0...70Vac/ 0...130Vac/ 0...250Vac/ 0...450Vac
45 Vac / 100 Vac / 180 Vac / 270 Vac / 475 Vac (short time)

Output

Output voltage/Output current
Offset voltage/Offset current
Load resistance voltage/Current
Accuracy
Temperature coefficient
Step response time
Status indicator

0...10 V/0(4)...20 mA
max. 0.02 V/max. 40 μ A
 $\geq 1 \text{ k}\Omega / < = 600 \Omega$
1.3 % (40...60 Hz) typ. 1 % / 2 % (70...400 Hz) typ. 1.5 %
 $\leq 250 \text{ ppm/K}$
300 ms
LED green

General data

Supply voltage
Current consumption
Current-carrying cap. of cross-connect.
Default settings
Operation temperature
Storage temperature
Approvals

24 Vdc +/- 25 %
40...30...24 mA at I_{out}=20 mA
 $\leq 2 \text{ A}$
0...10V/0...20mA
0 °C...+50 °C
-20 °C...+70 °C
CE / ESD / cURus

Insulation coordinates

Standards
EMC standards
Rated voltage
Impulse withstand voltage
Isolation voltage Input, output/
Overvoltage category
Pollution severity
Clearance & creepage path

EN 50178
EN 50081-1, EN 61000-2-6, EN 61326
supply/output: 300 V; input/output, supply/output: 600 V
supply/output: 4 kV; input/output, supply/output: 6kV
4 kVeff / 5s/
III
2
supply/output: 3mm; input/output, supply/output: 5.5mm

Dimensions

Clamping range (rating- / min. / max.) mm²
Length x width x height mm

Screw connection

2.50 / 0.50 / 2.50
92.4 x 22.5 x 112.4

Tension clamp c.

1.50 / 0.50 / 2.50
92.4 x 22.5 x 112.4

Information

T_u=23°C, single module

Ordering data

Type of connection

Screw connection
Tension clamp c.

Type

WAS2 VMA V ac
WAZ2 VMA V ac

Qty.

1
1

Order No.

8581220000
8581230000

Information

Accessories

Information

Voltage supply 24V and 0V with ZQV 2.5N/2 cross-connection

Threshold monitoring

Relay output

- 3-way disconnection
- Low trip / high trip
- FAILSAFE / NON FAILSAFE
- 2 Relay outputs 250Vac/3A

DC/Alarm

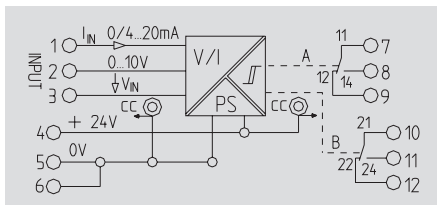
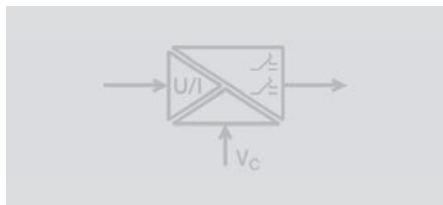

Switch position/setting options

function	SW 1			
	1	2	3	4
Kanal A High Trip	■			
Kanal A Low Trip	□			
Kanal B High Trip		■		
Kanal B Low Trip		□		
FAILSAFE, Kanal 1 & 2		□	□	
NON FAILSAFE, Kanal 1 & 2		■	■	

■ = on
□ = off

NON FAILSAFE: The relay picks up when the alarm is triggered

FAILSAFE: The relay drops out when the alarm is triggered. An alarm is also triggered in the FAILSAFE mode, if for example, the operating voltage to the moduls fail

Low Trip: Alarm is triggered if the signal is undershoot the threshold.

High Trip: Alarm is triggered if the signal is overshoot the threshold.

Signal threshold: Adjustments of the signal threshold (1...90%) are made for channel 1 with the potentiometer P1, and separately for channel 2 via potentiometer P2.

Hysterese: Adjustments of the hysteresis (1...10%) are made for channel 1 with the potentiometer P3, and separately for channel 2 via potentiometer P3.

WAVEANALOG DC/Alarm – Alarm indication

Example 1

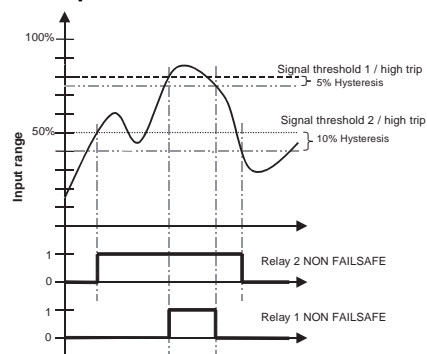

Example 2

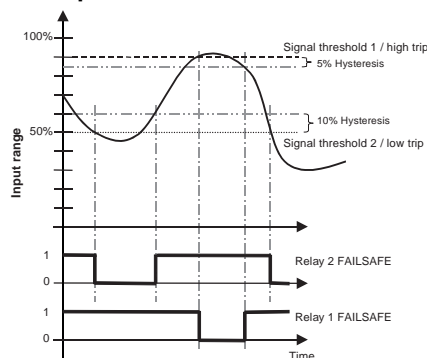

Technical data

Input

Input voltage
Input current
Input resistance voltage/Current

Output

Contact arrangement
Contact material
Switching thresholds
Hysteresis
Switching voltage max./Switching voltage min.
Continuous current
Function
Temperature coefficient
Status indicator

General data

Supply voltage
Power consumption
Current-carrying cap. of cross-connect.
Operation temperature
Storage temperature
Default settings
Approvals

Insulation coordinates

Standards
EMC standards
Rated voltage
Impulse withstand voltage
Pollution severity
Overvoltage category
Clearance & creepage path
Isolation voltage Input, output

0...10 V

0(4)...20 mA

>= 100 kΩ / <= 110 Ω

2 change-over contacts

AgNi 90/10

1...90 % (independently for channel 1 and channel 2)

1...90 % (independently for channel 1 and channel 2)

253 Vac/

3 A

failsafe / non failsafe

<= 500 ppm/K

LED green ON: OK, LED red ON: alarm (per channel)

24 Vdc +/- 25 %

typ. 1 W both relays picked up

<= 2 A

0 °C...+55 °C (fitted)

-20 °C...+85 °C

channel A/B: low trip and FAILSAFE

CE / ESD / cURus

EN 50178

EN 61000-4-2, -3, -4, -5, -6

300 V

4 kV

2

III

>= 3 mm

1.2 kVeff / 5s

Dimensions

Clamping range (rating- / min. / max.) mm²
Length x width x height mm

Information

Screw connection

2.50 / 0.50 / 2.50 1.50 / 0.50 / 2.50

92.4 x 17.5 x 112.4 92.4 x 17.5 x 112.4

Tu=23°C, single module

Ordering data

Type of connection

Screw connection
Tension clamp c.

Type

Type	Qty.	Order No.
WAS5 DC/Alarm	1	8543820000
WAZ5 DC/Alarm	1	8543880000

Information

Accessories

Information

Voltage supply 24V and 0V with ZQV 2.5N/2 cross-connection

Threshold monitoring

Transistor output

- 2 digital outputs
- Monitoring of upper and lower level

MCZ SC 0...10V

MCZ SC 0...20mA

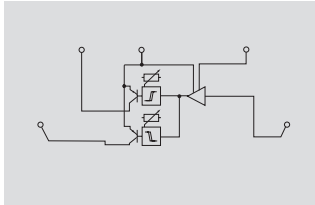
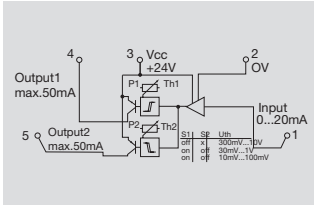
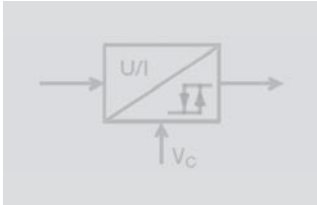
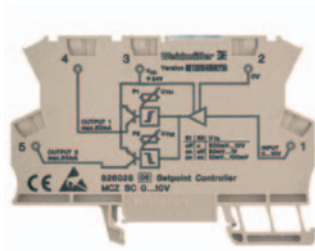
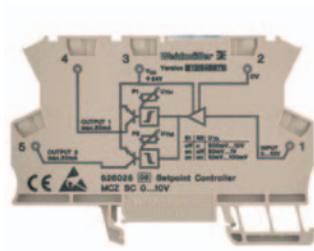

Technical data

Input

Input voltage/Input current
Input resistance voltage/Current
Voltage drop

Output

Contact arrangement/
Function
Switching thresholds
Hysteresis
Switching current max.
Step response time
Cut-off freq. (-3dB)
Temperature coefficient

General data

Supply voltage
Current consumption
Operation temperature
Storage temperature
Approvals

0...10 V/
60 kΩ/
double switch output PNP/
U_{in} < U_{th1}: Output 1 active / U_{in} > U_{th2}: Output 2 active
via 2 potentiometers (12 turns)
1% of adjusted final value
50 mA - per channel (voltage drop at output transistor: < 1.2 V at 50 mA)
< 250 μs (switch threshold at 90% of the max. input signal; R_i <= 1 kΩ)
100 Hz
250 ppm/K (max. 500 ppm/K)
24 Vdc +/- 20 %
15 mA
0 °C...+50 °C
-25 °C...+60 °C

/0.5...20 mA
/50 Ω
1 V
double switch output PNP/
I_{in} < I_{th1}: Output 1 active / I_{in} > I_{th2}: Output 2 active
via 2 potentiometers (12 turns)
1% of final value
50 mA - per channel (voltage drop at output transistor: < 1.2 V at 50 mA)
< 250 μs (switch threshold at 90% of the max. input signal; R_i <= 1 kΩ)
100 Hz
max. 250 ppm/K
24 Vdc +/- 20 %
15 mA
0 °C...+50 °C
-25 °C...+60 °C

Dimensions

Clamping range (rating- / min. / max.) mm²
Length x width x height mm

Information

Tension clamp c.

1.50 / 0.50 / 1.50
91.0 x 6.0 x 63.2

Tension clamp c.

1.50 / 0.50 / 1.50
91.0 x 6.0 x 63.2

Ordering data

Type of connection

Tension clamp c.

Type	(Qty.=1)	Order No.
MCZ SC 0-10V		8260280000

Type	(Qty.=1)	Order No.
MCZ SC 0-20MA		8227350000

Information

Accessories

Information

Voltage supply 24V and 0V with ZQV 4/x cross-connection

Voltage supply 24V and 0V with ZQV 4/x cross-connection

Accessories

MICROANALOG

Srew connection

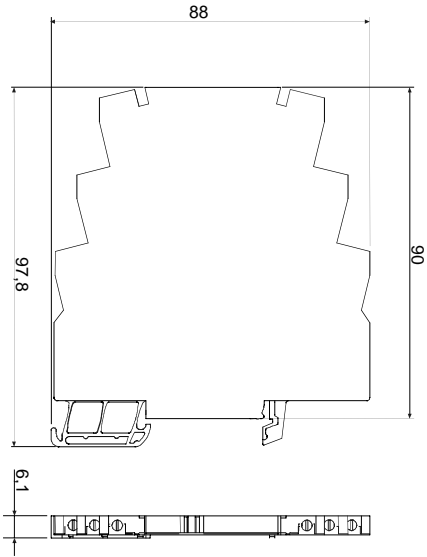

Tension clamp connection

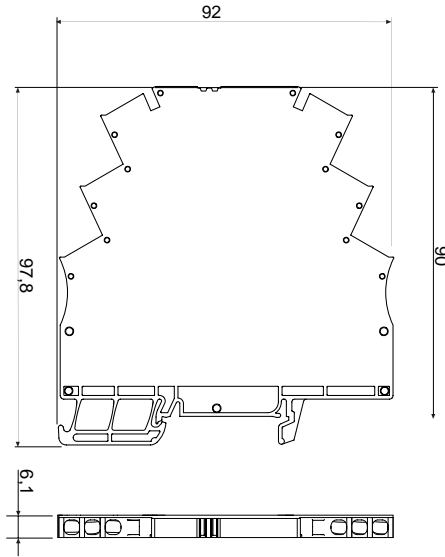

Accessories	
Cross connection, 2-poles, red	
Cross connection, 3-poles, red	
Cross connection, 4-poles, red	
Cross connection, 10-poles, red	
Cross connection, 41-poles, red	
Cross connection, 2-poles, blue	
Cross connection, 3-poles, blue	
Cross connection, 4-poles, blue	
Cross connection, 10-poles, blue	
Cross connection, 41-poles, blue	
Terminalmarker	

Type	Order no.	Qty
ZQV 4N/2 rt	1793950000	60
ZQV 4N/3 rt	1793980000	60
ZQV 4N/4 rt	1794010000	60
ZQV 4N/10 rt	1794040000	20
ZQV 4N/41 rt	1794070000	10
ZQV 4N/2 bl	1793960000	60
ZQV 4N/3 bl	1793990000	60
ZQV 4N/4 bl	1794020000	60
ZQV 4N/10 bl	1794050000	20
ZQV 4N/41 bl	1794080000	10
WS10/6	1060960000	200

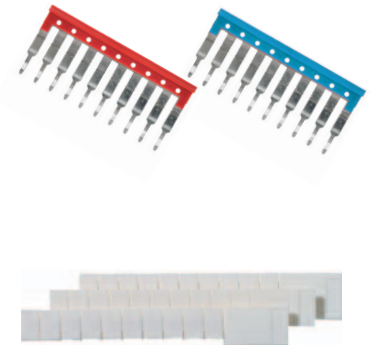

MCZ

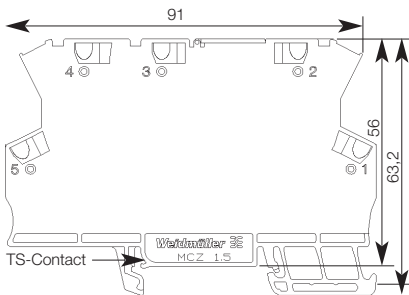

Accessories	
Cross connection, 2-poles, yellow	
Cross connection, 3-poles, yellow	
Cross connection, 4-poles, yellow	
Cross connection, 5-poles, yellow	
Cross connection, 6-poles, yellow	
Cross connection, 7-poles, yellow	
Cross connection, 8-poles, yellow	
Cross connection, 9-poles, yellow	
Cross connection, 10-poles, yellow	
Terminalmarker	

Type	Order no.	Qty
ZQV 4N/2 ge	1608950000	20
ZQV 4N/3 ge	1608960000	20
ZQV 4N/4 ge	1608970000	20
ZQV 4N/5 ge	1608980000	20
ZQV 4N/6 ge	1608990000	20
ZQV 4N/7 ge	1609000000	20
ZQV 4N/8 ge	1609010000	20
ZQV 4N/9 ge	1609020000	20
ZQV 4N/10 ge	1609030000	20
WS10/6	1060960000	200

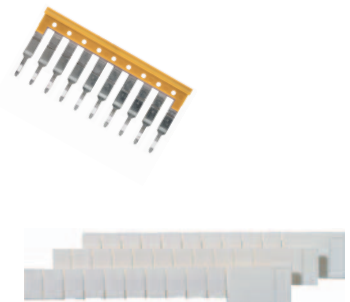

Accessories

WAVEBOX S 22,5

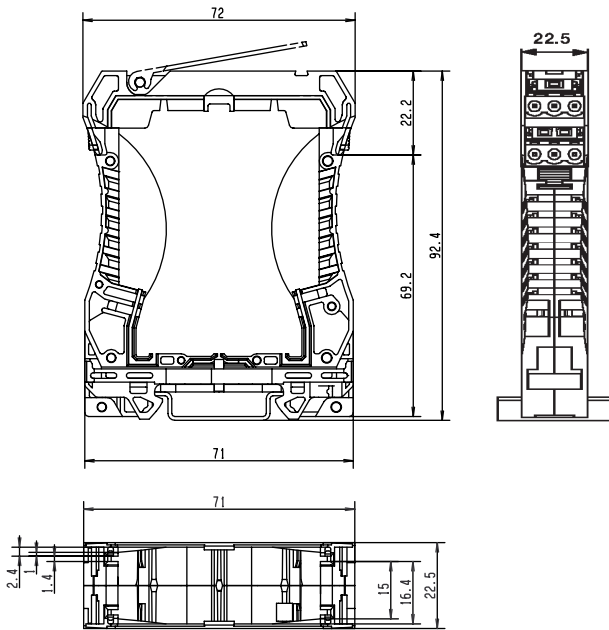

WAVEBOX L 22,5

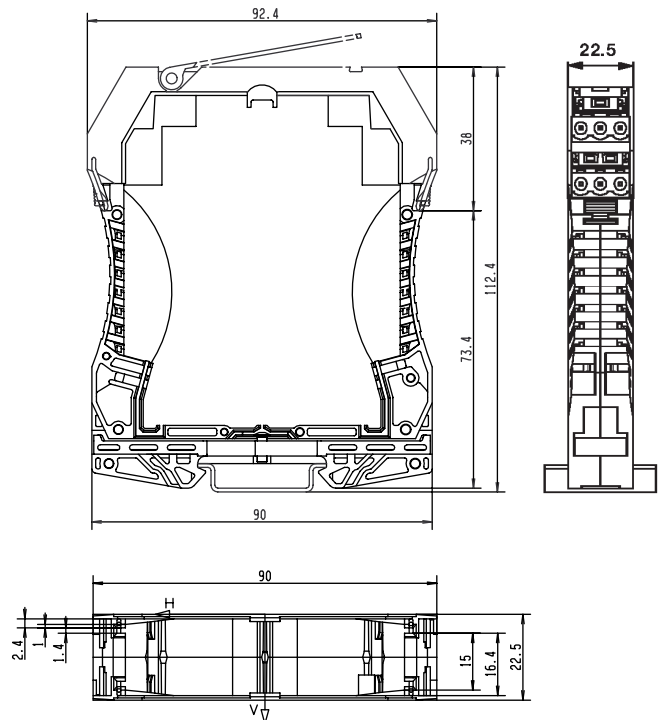

WAVEBOX 12,5

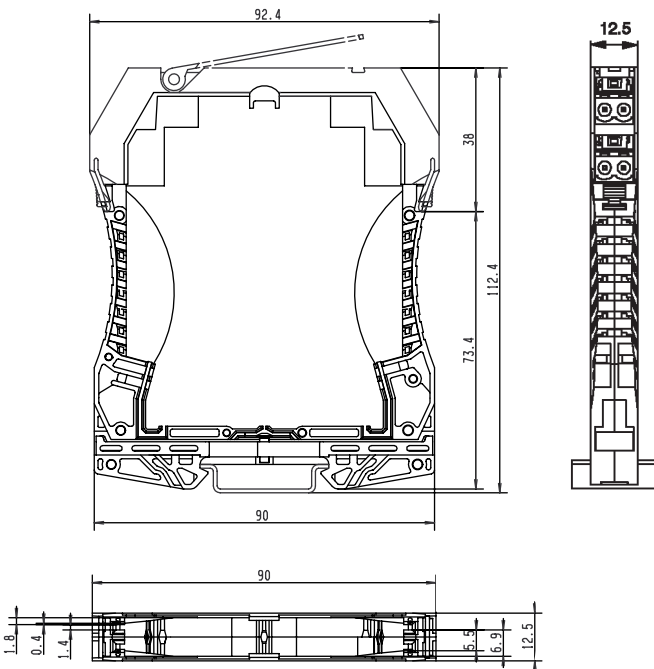

WAVEBOX 17,5

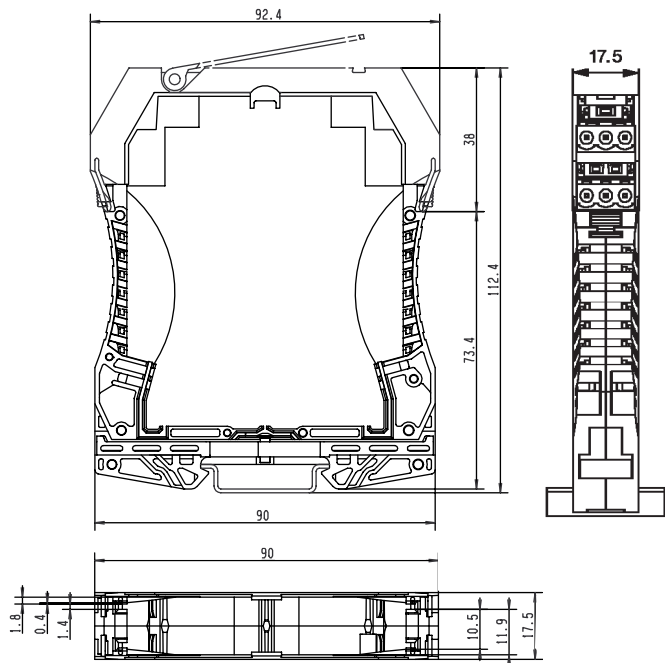

Accessories	
Cross connection ZQV 2,5N/2 black	
Cross connection ZQV 2,5N/2 red	
Cross connection ZQV 2,5N/2 blue	
Cross connection ZQV 2,5N/2 yellow	
Terminalmarkers	
WS 10/5 Multicard	
WS 10/5 Neutral	

Type	Order no.	Qty
ZQV 2,5N/2 sw	1718080000	60
ZQV 2,5N/2 rt	1717900000	60
ZQV 2,5N/2 bl	1717990000	60
ZQV 2,5N/2 ge	1693800000	60
Terminalmarkers		
WS 10/5	1635010000	144
WS 10/5 Neutral	1060860000	200

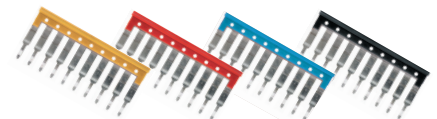

Articles with coloured order number are kept permanently in stock at the central warehouse in Germany. Delivery times see page X.2

