

FBAR/SAW Devices (SAW Type)

F6QA1G585M2AT

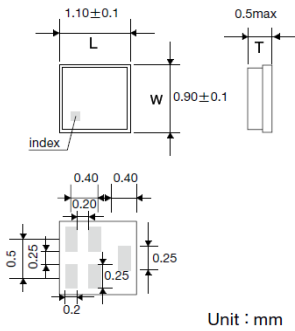

■ Features

- Item Summary
SAW, 1.1x0.9x0.5mm
- Lifecycle Stage
Mass Production
- Standard packaging quantity (minimum)
Taping Embossed 5000 , 15000pcs

■ Products characteristics table

System	GPS
Type	SAW
Function	Other
band	Other
Insertion Loss (typ)	1.1/1.4 dB
Operating Temp. Range	-30 to +85 °C
RoHS2 Compliance (10 subst.)	Yes
REACH Compliance (168 subst.)	Yes
Soldering	Reflow

■ External Dimensions

Dimension L	1.1 ± 0.10 mm
Dimension W	0.9 ± 0.10 mm
Dimension T	Max 0.5 mm

2016.05.21

The data is reference only. Electrical characteristics vary depending on environment or measurement condition.
 TAIYO YUDEN reserves the right to make change to the Date at any time without notice.
 Before making final selection, please check product specification.



*Pb Free part

Customer Name	Standard specifications	TAIYO YUDEN Mobile Technology Co.,Ltd.	
System	GPS+GLONASS (Unbalance 50/50 ohm)	Date	Sep. 5, 2012
Part Number	F6QA1G585M2AT	Version 1.0a	FINAL

Table 1.Electrical specifications

Passband:1565.42 ~ 1605.886 MHz						
Parameter	Frequency	Specification			Unit	Remarks
		Min.	Typ.	Max.		
Operating temperature		-30	-	+85	°C	
Insertion loss	1574.42-1576.42 MHz	-	1.1	1.4	dB	(*1)
Insertion loss	1565.42-1585.42 MHz		1.4	1.7	dB	(*1)
Insertion loss	1597.5515-1605.886 MHz	-	1.1	1.7	dB	(*1)
VSWR(input/output)	1574.42-1576.42 MHz	-	1.2	2.0	-	
	1565.42-1585.42 MHz		1.5	2.0	-	
	1597.5515-1605.886 MHz	-	1.5	2.0	-	
Absolute Attenuation	10 – 925 MHz	32	35	-	dB	
	925 – 960 MHz	32	35	-	dB	
	1427 – 1463 MHz	32	37	-	dB	
	1710 – 1785 MHz	32	39	-	dB	
	1850 – 1910 MHz	31	37	-	dB	
	1920 – 1980 MHz	31	36	-	dB	
	2401 – 2483 MHz	32	37	-	dB	
	2500 – 2570 MHz	32	36	-	dB	
Input impedance		50//36nH			ohm	
Output impedance		50			ohm	
Device Size		1.1typ. x 0.9typ. x 0.5max.			mm	

(*1) Specification of insertion loss includes loss that comes from the test board (0.1dB).



*Pb Free part

Customer Name	Standard specifications	TAIYO YUDEN Mobile Technology Co., Ltd.	
System	GPS+GLONASS (Unbalance 50/50 ohm)	Date	Sep. 5, 2012
Part Number	F6QA1G585M2AT	Version 1.0a	FINAL

Dimensions

Device size: 1.1typ. x 0.9typ. x 0.5max.

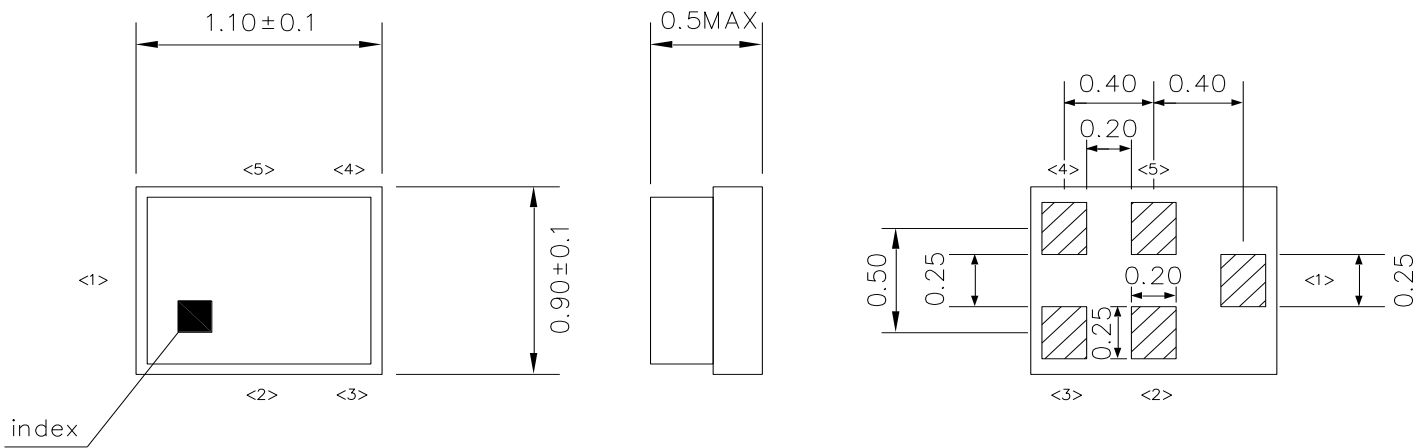

Unit: mm

Pin Configuration

Pin No.	Pin name	Description
1	IN	Unbalanced pin
2	GND	Ground
3	GND	Ground
4	OUT	Unbalanced pin
5	GND	Ground

Evaluation Circuit

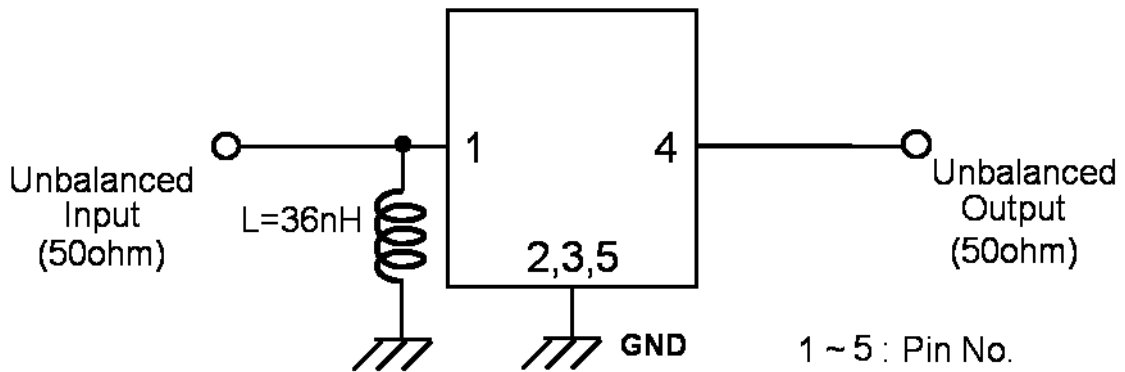



*Pb Free part

Customer Name	Standard specifications	TAIYO YUDEN Mobile Technology Co.,Ltd.	
System	GPS+GLONASS (Unbalance 50/50 ohm)	Date	Sep. 5, 2012
Part Number	F6QA1G585M2AT	Version 1.0a	FINAL

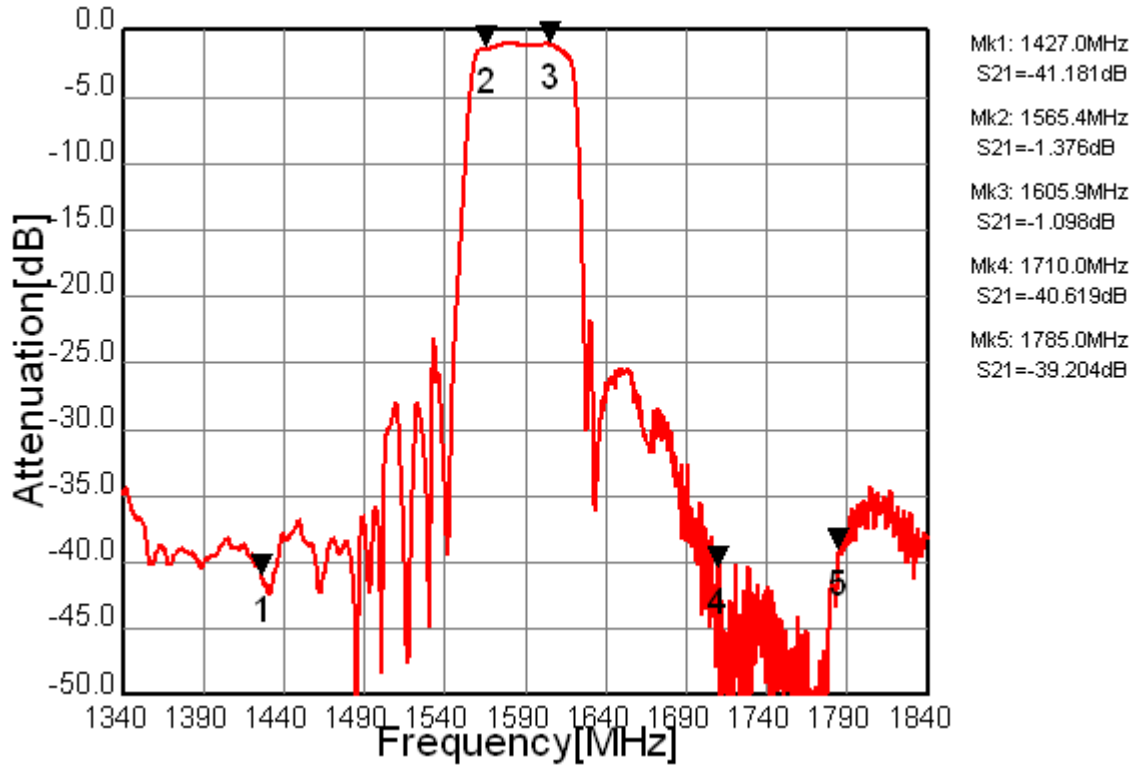

Fig.1 Pass-band Characteristics

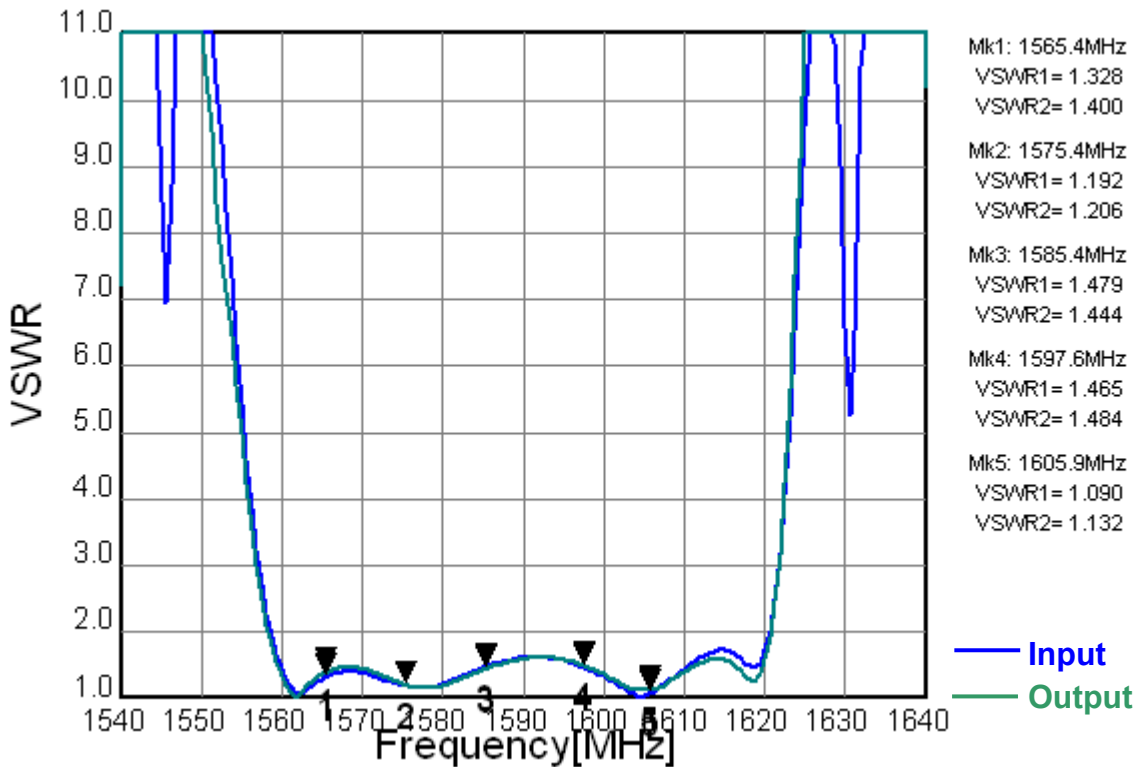

Fig.2 VSWR



*Pb Free part

Customer Name	Standard specifications	TAIYO YUDEN Mobile Technology Co.,Ltd.	
System	GPS+GLONASS (Unbalance 50/50 ohm)	Date	Sep. 5, 2012
Part Number	F6QA1G585M2AT	Version 1.0a	FINAL

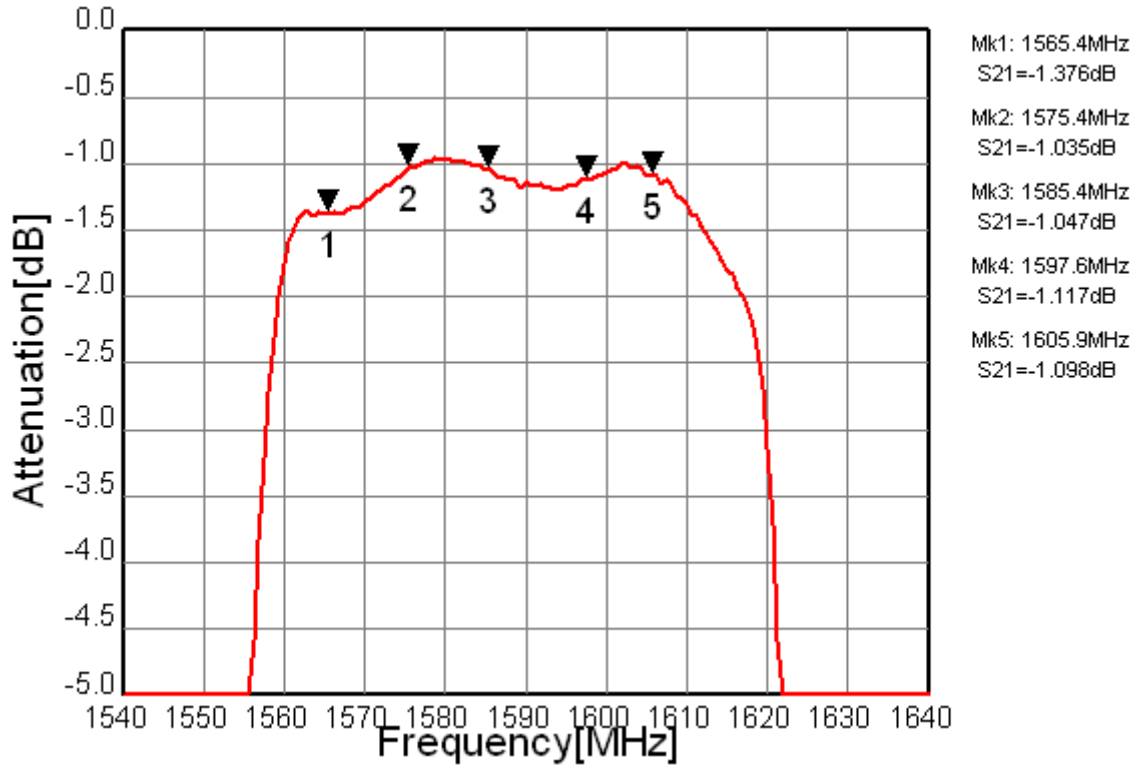

Fig.3 In-band Characteristics

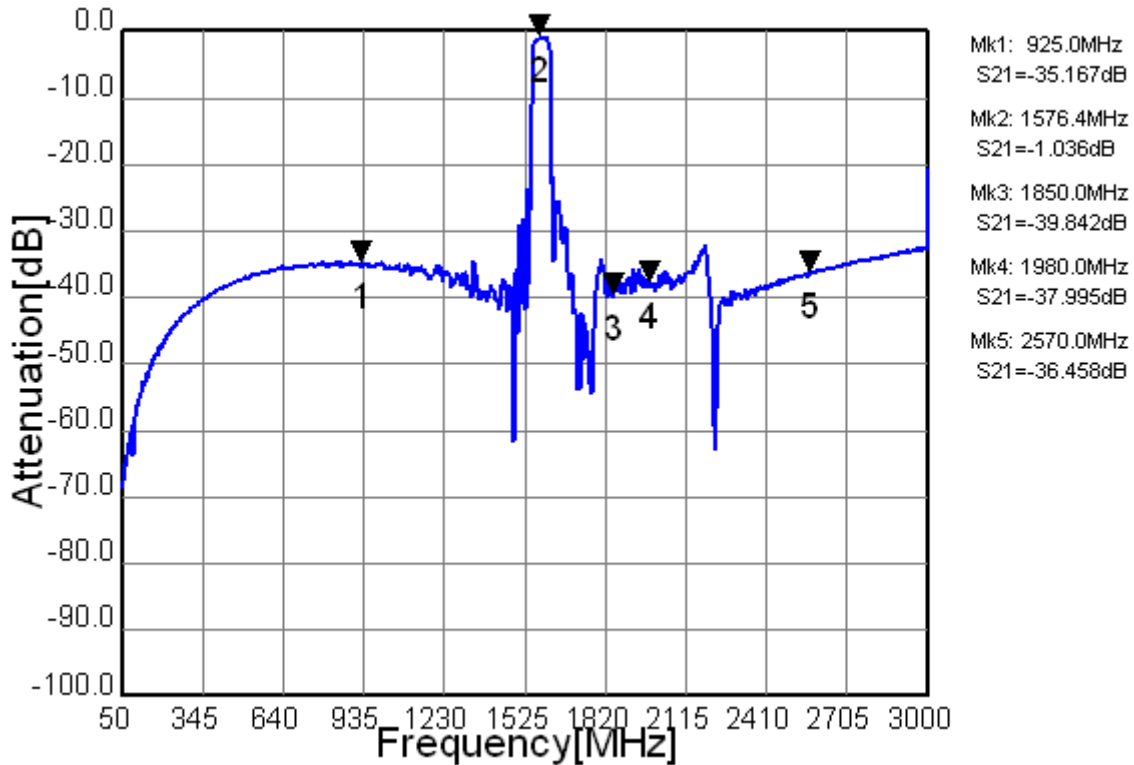

Fig.4 Wide-band Characteristics



RoHS MSL1

*Pb Free part

Customer Name	Standard specifications	TAIYO YUDEN Mobile Technology Co., Ltd.	
System	GPS+GLONASS (Unbalance 50/50 ohm)	Date	Sep. 5, 2012
Part Number	F6QA1G585M2AT	Version 1.0a	FINAL

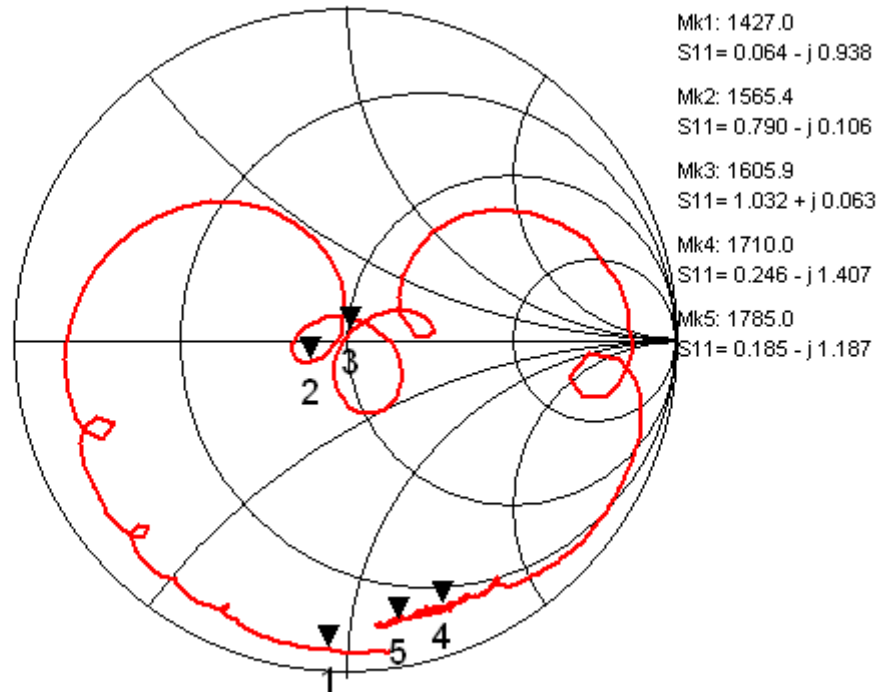

Fig.5 Input Impedance

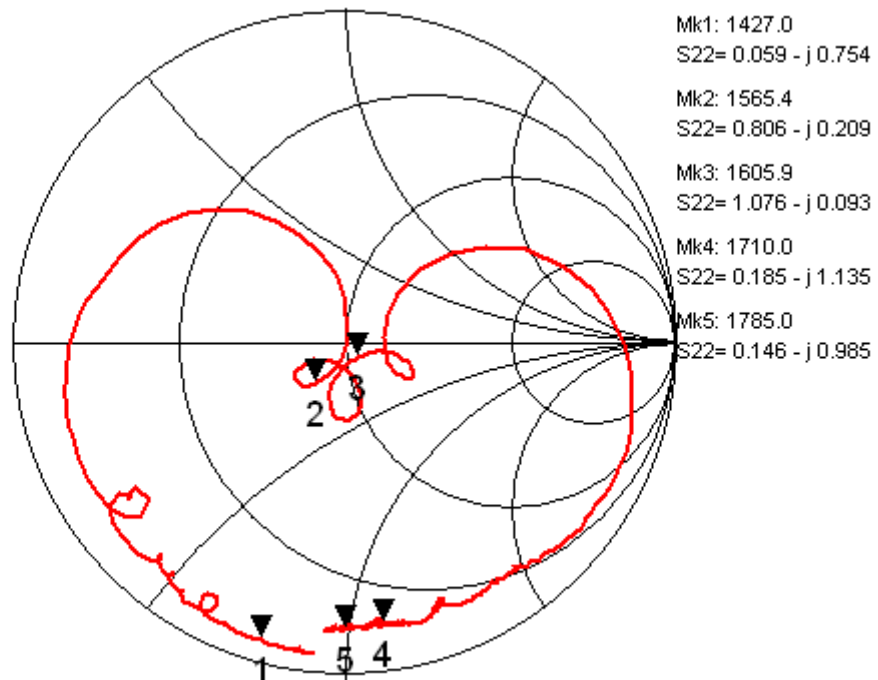

Fig.6 Output Impedance



*Pb Free part

Customer Name	Standard specifications	TAIYO YUDEN Mobile Technology Co., Ltd.	
System	GPS+GLONASS (Unbalance 50/50 ohm)	Date	Sep. 5, 2012
Part Number	F6QA1G585M2AT	Version 1.0a	FINAL

Ordering Code

Ordering Code	Packing	Reel size	Status
F6QA1G585M2AT-J	Tape & Reel	5,000pcs.	MP
F6QA1G585M2AT-JA	Tape & Reel	less than 5,000 pcs.	MP
F6QA1G585M2AT-Y	Tape & Reel	15,000pcs	MP
F6QA1G585M2AT-YA	Tape & Reel	less than 15,000 pcs.	MP
F6QA1G585M2AT-Q	Bulk	few pcs.	MP

*Minimum order quantity (MOQ) is assigned for each inquiry, Please contact to Sales Representatives.

*MP: Mass Production

Notice

All of the contents specified herein are subject to change without notice due to technical improvements, etc.

Please contact TAIYO YUDEN Co., Ltd. for further details of product specifications.

Please conduct validation and verification of products in actual condition of mounting and operating environment before commercial shipment of the equipment.

This product is for general electronics equipment such as Audio-Visual equipment, household electronics, office supplies, information services and telecommunications; therefore, in case this product is used for any medical equipment, space equipment, nuclear equipment or disaster prevention equipment, please contact TAIYO YUDEN in advance.

In case this product is used for general electronics equipment or circuits which require high safety and high reliability, thoroughly evaluate on safety and add a protection circuit if necessary.