

POLES	COIL VAC	FLA	RES	TERMINATION	COVER	INDIVIDUAL BOX
2	208/240 VAC 50/60Hz	30	40	#10-32 COMBINATION SCREWS 4 Quick Connect Power Termination	YES	YES

COIL DATA
 COIL 208/240VAC 50/60Hz
 1868 OHM 180 VAC OPERATE
 38.4-163 VAC DROPOUT
 26.8 VA INRUSH 5.4 VA SEAL
 MAX VOLTAGE 264 VAC

NOTES: UNLESS OTHERWISE SPECIFIED

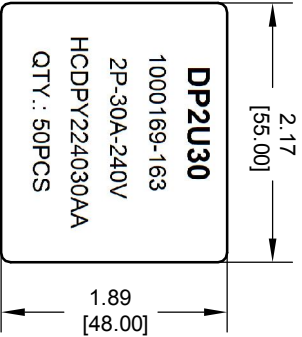
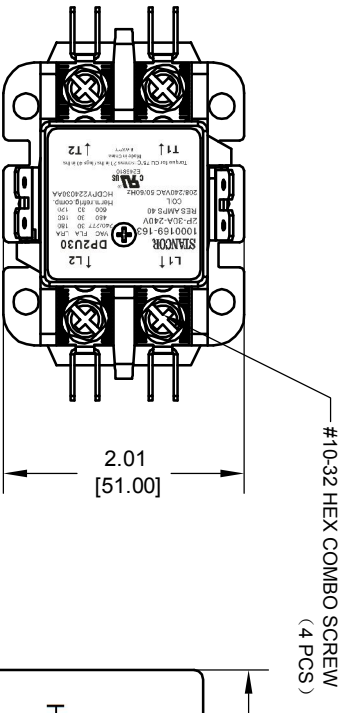
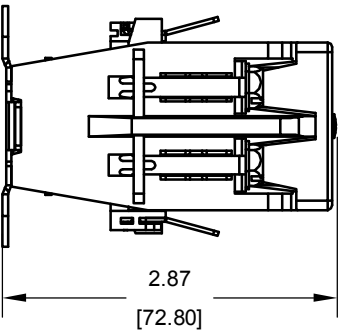
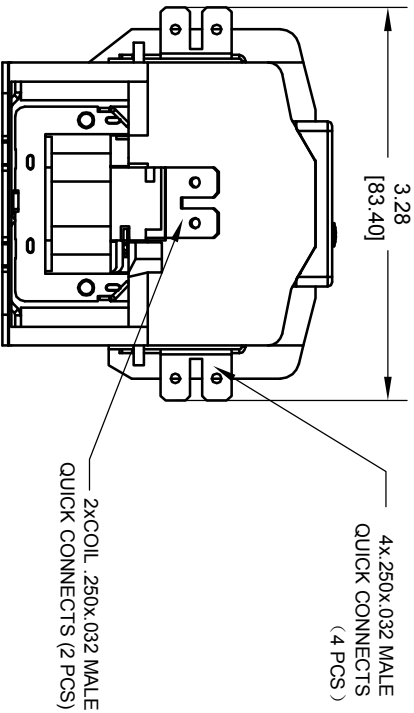
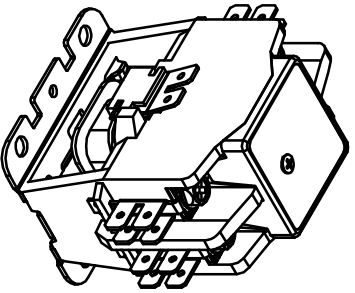
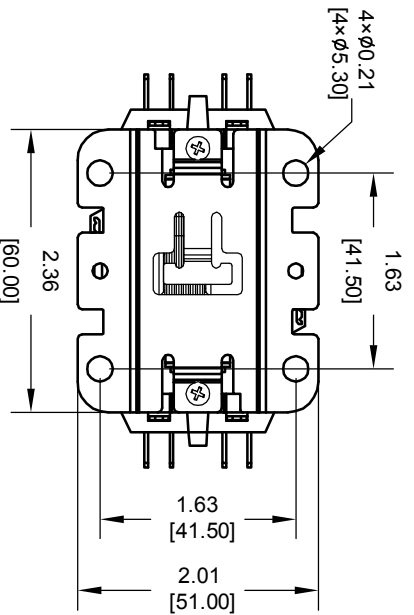

Master Carton Label

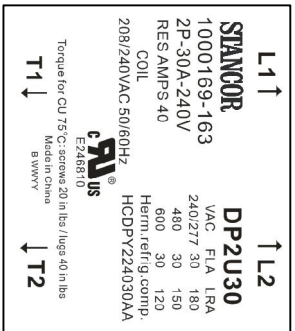

Product Label

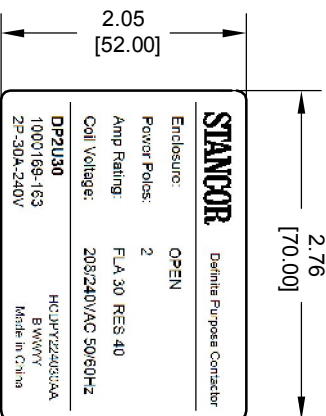

Individual Box Label

TOLERANCE	INCHES [mm]
X	+0.06 [1.50]
XX	+0.02 [50]
XXX	+0.006 [150]
X.XXX	+0.002 [050]
ANGLES	±1°

REV.	DESCRIPTION	EGN.	DMN.	APPD.	DATE

DESC. 2P-30A-240V

PART NO. DP2U30

STANCOR 2425 South 21st Street
 Phoenix, AZ 85034
 www.stancor.com (602)275-3800

DRAWN BY: [] DRAWN DATE: [] CHECKED BY: [] CHECKED DATE: []

PAGE 1 OF 1