

# Product data sheet

Specifications



## logic controller, Modicon M221, 24 IO, relay, Ethernet

TM221CE24R

**Product availability: Stock - Normally stocked in distribution facility**

### Main

Range of Product	Modicon M221
Product or Component Type	Logic controller
[Us] rated supply voltage	100...240 V AC
Discrete input number	14, discrete input IEC 61131-2 Type 1
Analogue input number	2 0...10 V
Discrete output type	Relay normally open
Discrete output number	10 relay
Discrete output voltage	5...125 V DC 5...250 V AC
Discrete output current	2 A

### Complementary

Discrete I/O number	24
Maximum number of I/O expansion module	7 (local I/O-Architecture) 14 (remote I/O-Architecture)
Supply voltage limits	85...264 V
Network Frequency	50/60 Hz
Inrush current	40 A
Maximum power consumption in VA	58 VA 100...240 V with max number of I/O expansion module 35 VA 100...240 V without I/O expansion module
Power supply output current	0.52 A 5 V expansion bus 0.16 A 24 V expansion bus
Discrete input logic	Sink or source (positive/negative)
Discrete input voltage	24 V
Discrete input voltage type	DC
Analogue input resolution	10 bits
LSB value	10 mV
Conversion time	1 ms per channel + 1 controller cycle time analog input
Permitted overload on inputs	+/- 30 V DC 5 min maximum)analog input +/- 13 V DC permanent)analog input
Voltage state 1 guaranteed	>= 15 V input
Voltage state 0 guaranteed	<= 5 V input
Discrete input current	7 mA discrete input 5 mA fast input

Price is "List Price" and may be subject to a trade discount – check with your local distributor or retailer for actual price.

<b>Input impedance</b>	3.4 kOhm discrete input 100 kOhm analog input 4.9 kOhm fast input
<b>Response time</b>	35 µs turn-off, I2...I5 input 10 ms turn-on output 10 ms turn-off output 5 µs turn-on, I0, I1, I6, I7 fast input 35 µs turn-on, other terminals input 5 µs turn-off, I0, I1, I6, I7 fast input 100 µs turn-off, other terminals input
<b>Configurable filtering time</b>	0 ms input 3 ms input 12 ms input
<b>Output voltage limits</b>	125 V DC 277 V AC
<b>Maximum current per output common</b>	4 A COM 2 7 A COM 0 7 A COM 1
<b>Absolute accuracy error</b>	+/- 1 % of full scale analog input
<b>Electrical durability</b>	100000 cycles AC-12, 120 V, 240 VA, resistive 100000 cycles AC-12, 240 V, 480 VA, resistive 300000 cycles AC-12, 120 V, 80 VA, resistive 300000 cycles AC-12, 240 V, 160 VA, resistive 100000 cycles AC-15, cos phi = 0.35, 120 V, 60 VA, inductive 100000 cycles AC-15, cos phi = 0.35, 240 V, 120 VA, inductive 300000 cycles AC-15, cos phi = 0.35, 120 V, 18 VA, inductive 300000 cycles AC-15, cos phi = 0.35, 240 V, 36 VA, inductive 100000 cycles AC-14, cos phi = 0.7, 120 V, 120 VA, inductive 100000 cycles AC-14, cos phi = 0.7, 240 V, 240 VA, inductive 300000 cycles AC-14, cos phi = 0.7, 120 V, 36 VA, inductive 300000 cycles AC-14, cos phi = 0.7, 240 V, 72 VA, inductive 100000 cycles DC-12, 24 V, 48 W, resistive 300000 cycles DC-12, 24 V, 16 W, resistive 100000 cycles DC-13, 24 V, 24 W, inductive (L/R = 7 ms) 300000 cycles DC-13, 24 V, 7.2 W, inductive (L/R = 7 ms)
<b>Switching frequency</b>	20 switching operations/minute with maximum load
<b>Mechanical durability</b>	20000000 cycles relay output
<b>Minimum load</b>	1 mA 5 V DC relay output
<b>Protection type</b>	Without protection 5 A
<b>Reset time</b>	1 s
<b>Memory capacity</b>	256 kB user application and data RAM 10000 instructions 256 kB internal variables RAM
<b>Data backed up</b>	256 kB built-in flash memory backup of application and data
<b>Data storage equipment</b>	2 GB SD card optional)
<b>Battery type</b>	BR2032 or CR2032X lithium non-rechargeable
<b>Backup time</b>	1 year 77 °F (25 °C) by interruption of power supply)
<b>Execution time for 1 KInstruction</b>	0.3 ms event and periodic task
<b>Execution time per instruction</b>	0.2 µs Boolean
<b>Exct time for event task</b>	60 µs response time
<b>Maximum size of object areas</b>	255 %TM timers 512 %M memory bits 8000 %MW memory words 255 %C counters 512 %KW constant words
<b>Realtime clock</b>	With
<b>Clock drift</b>	<= 30 s/month 77 °F (25 °C)
<b>Regulation loop</b>	Adjustable PID regulator up to 14 simultaneous loops

<b>Counting input number</b>	4 fast input (HSC mode) 100 kHz 32 bits
<b>counter function</b>	A/B Single phase Pulse/direction
<b>Integrated connection type</b>	USB port mini B USB 2.0 Non isolated serial link serial 1 RJ45 RS232/RS485 Ethernet RJ45
<b>Supply</b>	Serial)serial link supply 5 V, <200 mA
<b>Transmission rate</b>	1.2...115.2 kbit/s (115.2 kbit/s by default) 49.2 ft (15 m) RS485 1.2...115.2 kbit/s (115.2 kbit/s by default) 9.8 ft (3 m) RS232 480 Mbit/s USB
<b>Communication port protocol</b>	USB port USB - SoMachine-Network Non isolated serial link Modbus master/slave - RTU/ASCII or SoMachine-Network Ethernet
<b>Port Ethernet</b>	10BASE-T/100BASE-TX 1 328.08 ft (100 m) copper cable
<b>Communication Service</b>	Modbus TCP server Modbus TCP slave device DHCP client Modbus TCP client Ethernet/IP adapter
<b>Local signalling</b>	1 LED (green) for PWR 1 LED (green) for RUN 1 LED (red) for module error (ERR) 1 LED (green) for SD card access (SD) 1 LED (red) for BAT 1 LED per channel (green) for I/O state 1 LED (green) for SL Ethernet network activity (green) for ACT Ethernet network link (yellow) for Link (Link Status)
<b>Electrical connection</b>	removable screw terminal block for inputs removable screw terminal block for outputs terminal block, 3 for connecting the 24 V DC power supply connector, 4 for analogue inputs Mini B USB 2.0 connector for a programming terminal
<b>Maximum cable distance between devices</b>	Shielded cable <32.8 ft (10 m) fast input Unshielded cable <98.4 ft (30 m) output Unshielded cable <98.4 ft (30 m) digital input Unshielded cable <3.3 ft (1 m) analog input
<b>Insulation</b>	Between input and internal logic 500 V AC Non-insulated between analogue input and internal logic Non-insulated between analogue inputs Between supply and ground 1500 V AC Between sensor power supply and ground 500 V AC Between input and ground 500 V AC Between output and ground 1500 V AC Between supply and internal logic 2300 V AC Between sensor power supply and internal logic 500 V AC Between output and internal logic 2300 V AC Between Ethernet terminal and internal logic 500 V AC Between supply and sensor power supply 2300 V AC
<b>Marking</b>	CE
<b>Sensor power supply</b>	24 V DC 250 mA supplied by the controller
<b>Mounting support</b>	Top hat type TH35-15 rail IEC 60715 Top hat type TH35-7.5 rail IEC 60715 plate or panel with fixing kit
<b>Height</b>	3.5 in (90 mm)
<b>Depth</b>	2.8 in (70 mm)
<b>Width</b>	4.3 in (110 mm)
<b>Net Weight</b>	0.871 lb(US) (0.395 kg)

## Environment

<b>Standards</b>	IEC 61131-2 UL 508 CAN/CSA C22.2 No. 213 IACS E10 ANSI/ISA 12-12-01
<b>Product Certifications</b>	LR cULus ABS DNV-GL EAC RCM CE UKCA cULus HazLoc
<b>Environmental characteristic</b>	Ordinary and hazardous location
<b>Resistance to electrostatic discharge</b>	8 kV in air IEC 61000-4-2 4 kV on contact IEC 61000-4-2
<b>Resistance to electromagnetic fields</b>	9.1 V/m (10 V/m) 80 MHz...1 GHz IEC 61000-4-3 2.7 V/m (3 V/m) 1.4 GHz...2 GHz IEC 61000-4-3 0.9 V/m (1 V/m) 2...2.7 GHz IEC 61000-4-3
<b>Resistance to magnetic fields</b>	98.4 A/m (30 A/m) 50/60 Hz IEC 61000-4-8
<b>Resistance to fast transients</b>	2 kV IEC 61000-4-4 power lines) 2 kV IEC 61000-4-4 relay output) 1 kV IEC 61000-4-4 I/O) 1 kV IEC 61000-4-4 Ethernet line) 1 kV IEC 61000-4-4 serial link)
<b>Surge withstand</b>	2 kV power lines (AC) common mode IEC 61000-4-5 2 kV relay output common mode IEC 61000-4-5 1 kV I/O common mode IEC 61000-4-5 1 kV shielded cable common mode IEC 61000-4-5 0.5 kV power lines (DC) differential mode IEC 61000-4-5 1 kV power lines (AC) differential mode IEC 61000-4-5 1 kV relay output differential mode IEC 61000-4-5 0.5 kV power lines (DC) common mode IEC 61000-4-5
<b>Resistance to conducted disturbances</b>	10 V 0.15...80 MHz IEC 61000-4-6 3 V 0.1...80 MHz Marine specification (LR, ABS, DNV, GL) 10 V spot frequency (2, 3, 4, 6.2, 8.2, 12.6, 16.5, 18.8, 22, 25 MHz) Marine specification (LR, ABS, DNV, GL)
<b>Electromagnetic emission</b>	Conducted emissions 79 dB $\mu$ V/m QP/66 dB $\mu$ V/m AV power lines (AC))0.15...0.5 MHz IEC 55011 Conducted emissions 73 dB $\mu$ V/m QP/60 dB $\mu$ V/m AV power lines (AC))0.5...300 MHz IEC 55011 Conducted emissions 120...69 dB $\mu$ V/m QP power lines)10...150 kHz IEC 55011 Conducted emissions 63 dB $\mu$ V/m QP power lines)1.5...30 MHz IEC 55011 Radiated emissions 40 dB $\mu$ V/m QP class A 10 m)30...230 MHz IEC 55011 Conducted emissions 79...63 dB $\mu$ V/m QP power lines)150...1500 kHz IEC 55011 Radiated emissions 47 dB $\mu$ V/m QP class A 10 m)200...1000 MHz IEC 55011
<b>Immunity to microbreaks</b>	10 ms
<b>Ambient air temperature for operation</b>	14...131 °F (-10...55 °C) horizontal installation) 14...95 °F (-10...35 °C) vertical installation)
<b>Ambient Air Temperature for Storage</b>	-13...158 °F (-25...70 °C)
<b>Relative humidity</b>	10...95 %, without condensation in operation) 10...95 %, without condensation in storage)
<b>IP degree of protection</b>	IP20 with protective cover in place
<b>pollution degree</b>	<= 2
<b>Operating altitude</b>	0...6561.68 ft (0...2000 m)
<b>Storage altitude</b>	0...9842.5 ft (0...3000 m)
<b>Vibration resistance</b>	3.5 mm 5...8.4 Hz symmetrical rail 3.5 mm 5...8.4 Hz panel mounting 1 gn 8.4...150 Hz symmetrical rail 1 gn 8.4...150 Hz panel mounting

---

Shock resistance	98 m/s <sup>2</sup> 11 ms
------------------	---------------------------

---

## Ordering and shipping details

---

Category	US10MSX22533
Discount Schedule	0MSX
GTIN	3606480648779
Returnability	Yes
Country of origin	SG

---

## Packing Units

---

Unit Type of Package 1	PCE
Number of Units in Package 1	1
Package 1 Height	4.33 in (11.000 cm)
Package 1 Width	6.10 in (15.500 cm)
Package 1 Length	5.51 in (14.000 cm)
Package 1 Weight	22.222 oz (630.000 g)
Unit Type of Package 2	S04
Number of Units in Package 2	20
Package 2 Height	11.81 in (30.000 cm)
Package 2 Width	15.75 in (40.000 cm)
Package 2 Length	23.62 in (60.000 cm)
Package 2 Weight	30.181 lb(US) (13.690 kg)
Unit Type of Package 3	P12
Number of Units in Package 3	240
Package 3 Height	41.34 in (105.000 cm)
Package 3 Width	47.24 in (120.000 cm)
Package 3 Length	31.50 in (80.000 cm)
Package 3 Weight	401.242 lb(US) (182.000 kg)

---

## Environmental Data

Schneider Electric aims to achieve Net Zero status by 2050 through supply chain partnerships, lower impact materials, and circularity via our ongoing “Use Better, Use Longer, Use Again” campaign to extend product lifetimes and recyclability.

[Environmental Data explained >](#)



[How we assess product sustainability >](#)

 Environmental footprint	
Carbon footprint (kg CO2 eq, Total Life cycle)	122
Environmental Disclosure	<a href="#">Product Environmental Profile</a>

### Use Better

 Materials and Substances	
Packaging made with recycled cardboard	Yes
Packaging without single use plastic	Yes
<a href="#">EU RoHS Directive</a>	Pro-active compliance (Product out of EU RoHS legal scope)
REACH Regulation	<a href="#">REACH Declaration</a>
California proposition 65	<b>WARNING:</b> This product can expose you to chemicals including: Lead and lead compounds, which is known to the State of California to cause cancer and birth defects or other reproductive harm. For more information go to <a href="http://www.P65Warnings.ca.gov">www.P65Warnings.ca.gov</a>
PVC free	Yes

### Use Again

 Repack and remanufacture	
Circularity Profile	<a href="#">End of Life Information</a>
Take-back	No
WEEE	 The product must be disposed on European Union markets following specific waste collection and never end up in rubbish bins.

Dimensions Drawings

Dimensions

---

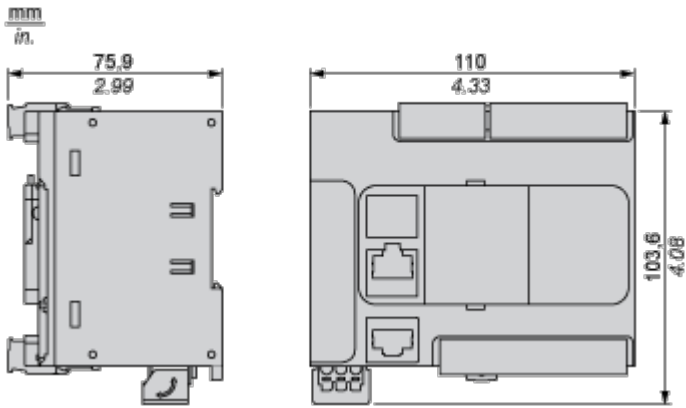

Mounting and Clearance

Mounting on a Rail

---

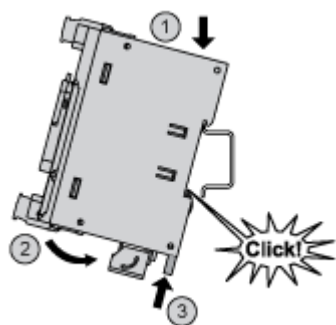

Direct Mounting on a Panel Surface

---

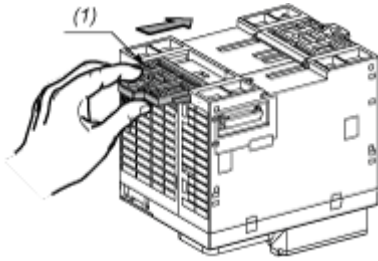

(1) Install a mounting strip

Mounting Hole Layout

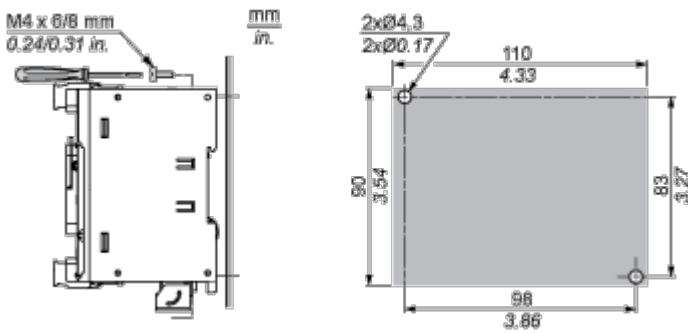

Mounting

---

**Correct Mounting Position**

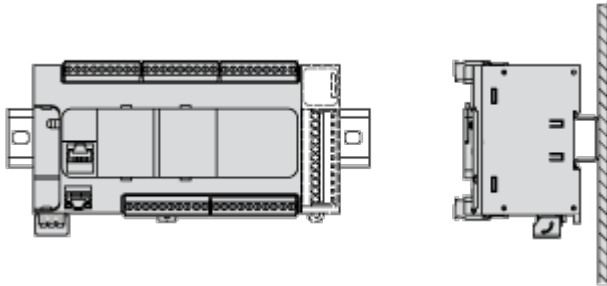

**Acceptable Mounting Position**

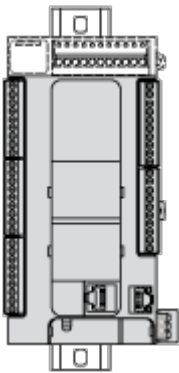

**Incorrect Mounting Position**

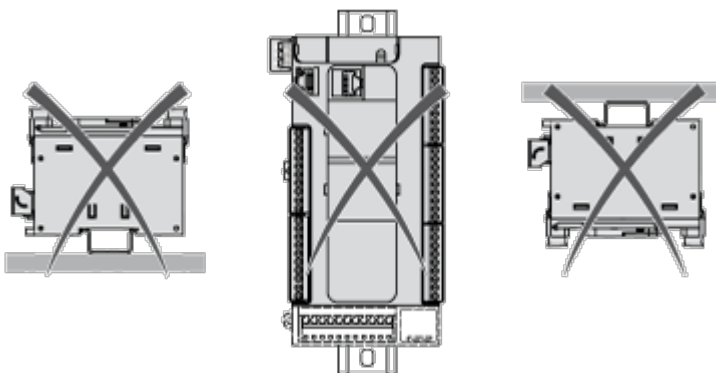

Clearance

---

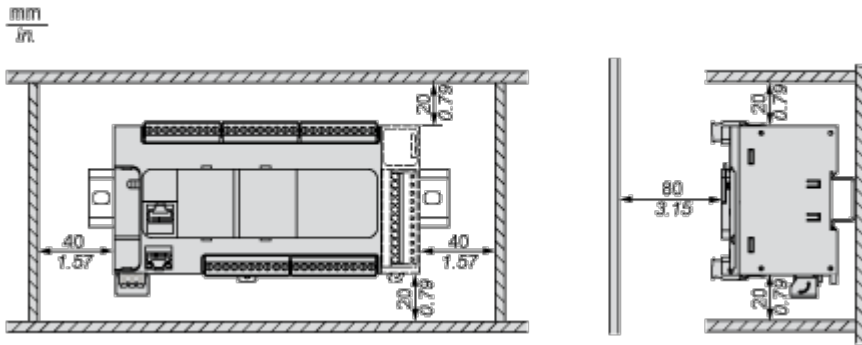

Connections and Schema

Digital Inputs

---

Wiring Diagram (Positive Logic)

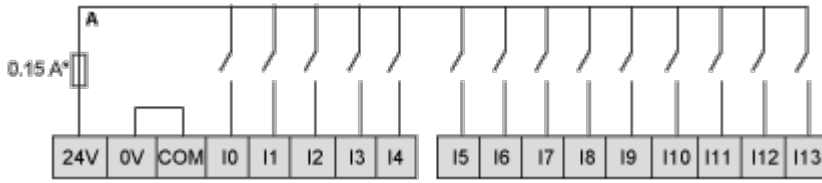

(\*) Type T fuse

Wiring Diagram (Negative Logic)

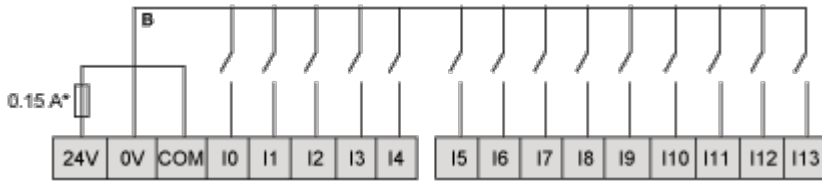

(\*) Type T fuse

Connection of the Fast Inputs

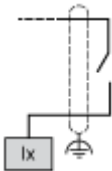

I0, I1, I6, I7

Relay Outputs

Negative Logic (Sink)

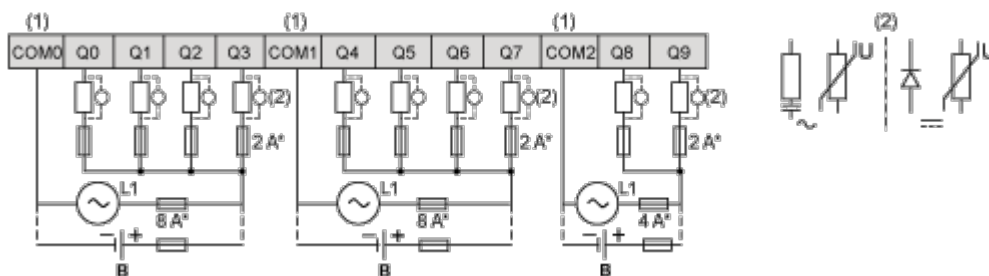

(\*) Type T fuse

(1) The COM0, COM1 and COM2 terminals are not connected internally.

(2) To improve the life time of the contacts, and to protect from potential inductive load damage, you must connect a free wheeling diode in parallel to each inductive DC load or an RC snubber in parallel of each inductive AC load

B Sink wiring (negative logic)

Positive Logic (Source)

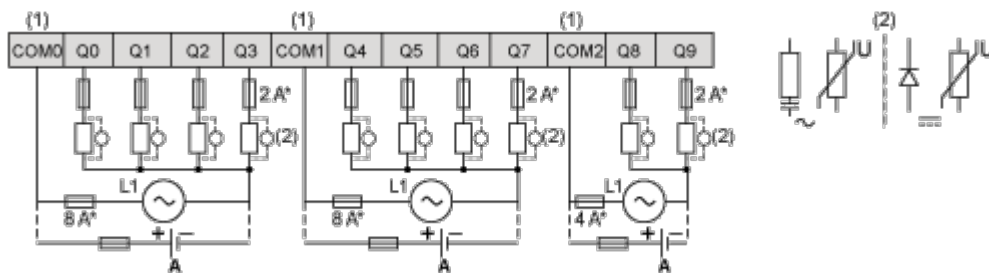

(\*) Type T fuse

(1) The COM0, COM1 and COM2 terminals are not connected internally.

(2) To improve the life time of the contacts, and to protect from potential inductive load damage, you must connect a free wheeling diode in parallel to each inductive DC load or an RC snubber in parallel of each inductive AC load

A Source wiring (positive logic)

Analog Inputs

---

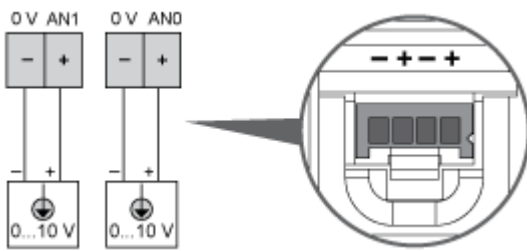
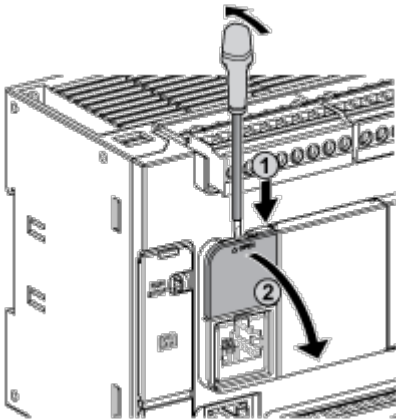

The (-) poles are connected internally.

Pin	Wire Color
0 V	Black
AN1	Red
0 V	Black
AN0	Red

Ethernet Connection

---

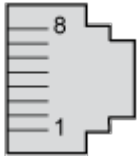

Pin N°	Signal
1	TD+
2	TD-
3	RD+
4	-
5	-
6	RD-
7	-
8	-

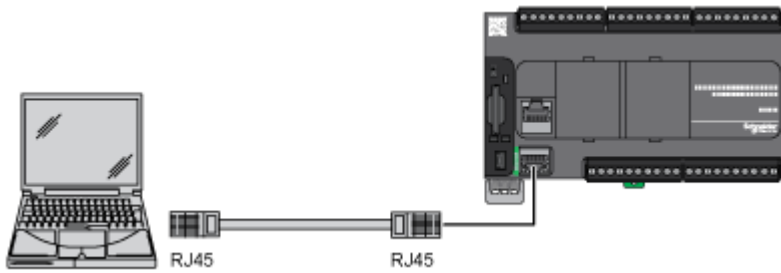

USB Mini-B Connection

---

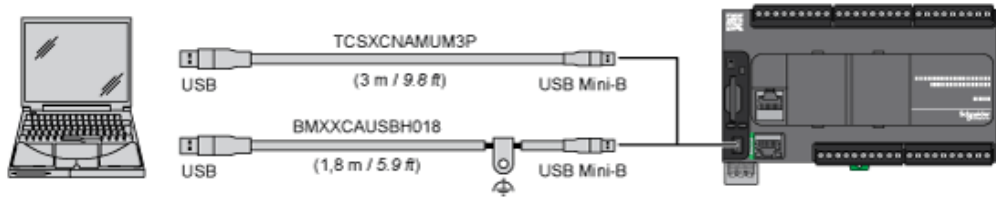

SL1 Connection

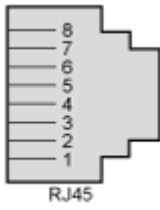

SL1

N °	RS 232	RS 485
1	RxD	N.C.
2	TxD	N.C.
3	RTS	N.C.
4	N.C.	D1
5	N.C.	D0
6	CTS	N.C.
7	N.C.*	5 Vdc
8	Common	Common

N.C.: not connected

\* : 5 Vdc delivered by the controller. Do not connect.

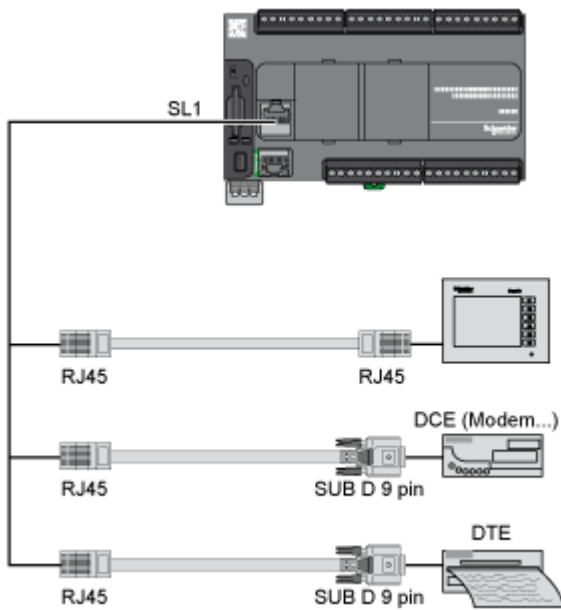

Performance Curves

Derating Curves

---

**Embedded Digital Inputs (No Cartridge)**

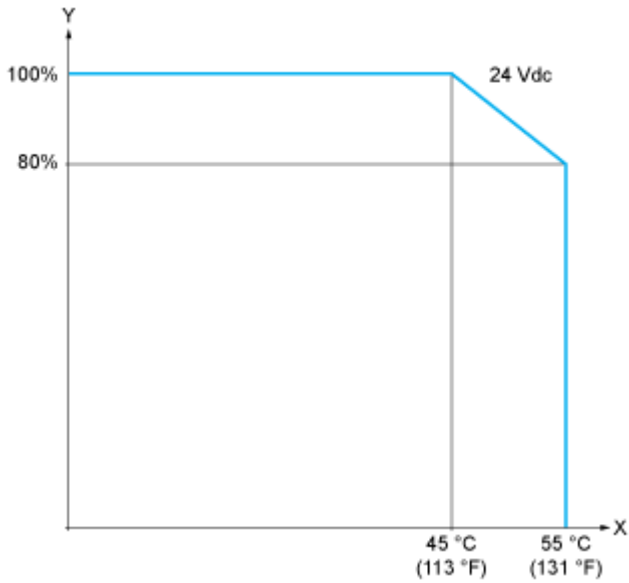

X : Ambient temperature

Y : Input simultaneous ON ratio

**Embedded Digital Inputs (with Cartridge)**

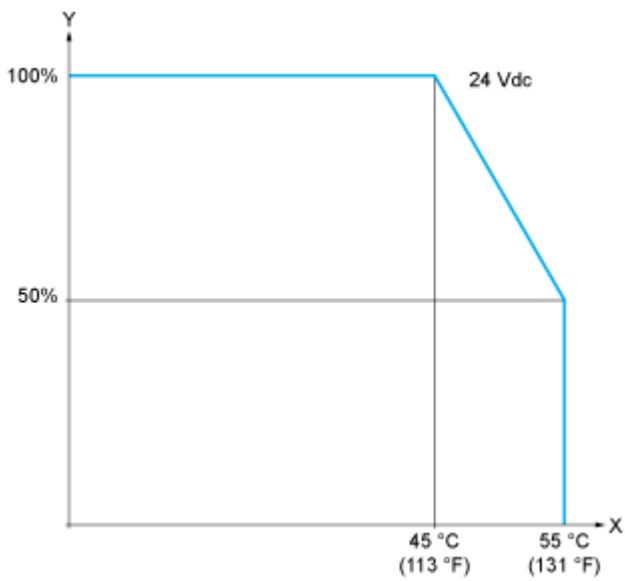

X : Ambient temperature

Y : Input simultaneous ON ratio