



# Mini-Max M235 Series Digital Panel Meter

- **Minimum Depth Indicator - Less Than 2.5" (60mm) of Space Required Behind the Panel**
- **Stackable Mounting Bracket Included for Easy Installation**
- **3-1/2 Digit, 0.5" (12.7mm) High LCD Display with Optional Negative Image, Bright Red Backlighting**
- **Limited Range Display Scaling**
- **Standard Screw Terminals for Easy Installation**
- **Six Current Ranges: 200µA, 2mA, 20mA, 200mA, 2A, 5A**
- **85-250VAC or 9-32VDC Power Supply**



Simpson's Mini-Max Current Indicators provide high quality, accuracy and reliability in a compact, 60mm deep case. Units offer 3-1/2 digit, 0.5" (12.7mm) LCD display and are available with a bright red, negative image backlight option. All units feature user-selectable decimal point, auto zero and limited scaling capabilities.

A unique mounting bracket is provided to allow for vertical or horizontal stacking of multiple indicators. All Mini-Max units feature a 3/64 DIN, high-impact plastic case. The standard units have a clear viewing window, and the units with optional negative image, red backlighting have a red window.

## Installation and Panel Cutout

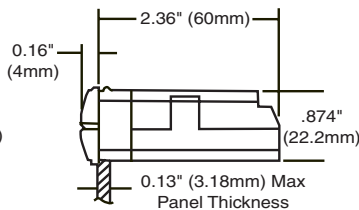
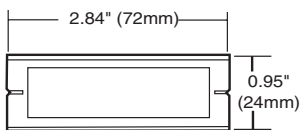
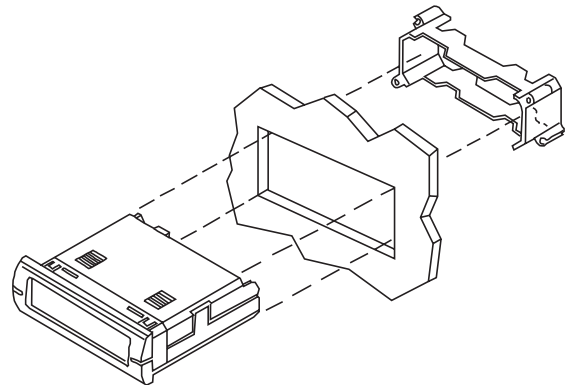
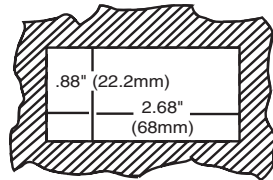
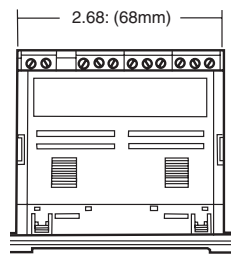

### Mounting Requirements

Insert the Mini-Max through the panel, and then slide the mounting bracket on to the Mini-Max. The mounting bracket allows Mini-Max units to be stacked side-to-side or top-to-bottom and maintain the DIN standard panel arrangements in 24mm by 72mm multiples. Panel cutout instructions for stacking multiple units are provided under "Stacking Features."

# Specifications

## DISPLAY

**Type:** 7-segment LCD  
**Height:** 0.5" (12.7mm)  
**Decimal point:** 3 -position programmable  
**Overrange indication:** Most significant digit = "1"  
**Backlighting:** Optional negative image, red back-lighting

**Polarity:** Auto with "-" indication, "+" implied

## POWER REQUIREMENTS

**AC Volt:** 85-250VAC @40-440Hz  
**DC Volt:** 9-32VDC

## Power Consumption:

85-250VAC: 2.5VA min/4VA max  
 9-32VDC: 1.5VA min/3VA max

**Rated Circuit to Ground Voltage:** 750VRMS

## ACCURACY @ 25°C

±(0.1% of reading + 1 count)  
**2A:** ±(0.25% of reading + 1 count)  
**5A:** ±(0.50% of reading + 1 count)

## ENVIRONMENTAL

**Operating Temperature:** 0 to 55°C  
**Storage Temperature:** -10 to 60°C  
**Relative Humidity:** 0 to 85% non condensing @ 40°C  
**Temperature Coefficient:**  
 (± 0.02% of input ± 0.2 digits)/°C  
**Warmup time:** Less than 20 minutes

## NOISE REJECTION

**NMR:** 60dB, 50/60Hz  
**CMRR:** (w/1KΩ unbalanced @ 60Hz): 90dB min

## ANALOG TO DIGITAL CONVERSION

**Technique:** Integrating  
**Rate:** 3 samples/second-typical

## MECHANICAL

**Bezel:** 0.95" x 2.84"  
 (24mm x 72mm)  
**Depth:** 2.36"(60mm)  
**Panel cutout:** 0.88" x 2.68"  
 (22.2mm x 68mm)  
**Weight:** 3.5oz (99.2g)  
**Case Material:**  
 94-0,UL rated glass-filled thermoplastic

## INPUTS: DC Current

Range	Resolution	Voltage Drop	Max Input (unfused)
200µA	100nA	200mV	10mA
2mA	1µA	200mV	40mA
20mA	10µA	200mV	100mA
200mA	100µA	200mV	400mA
2A	1mA	200mV	3A
5A	10mA	50mV	6A

# Wiring Display

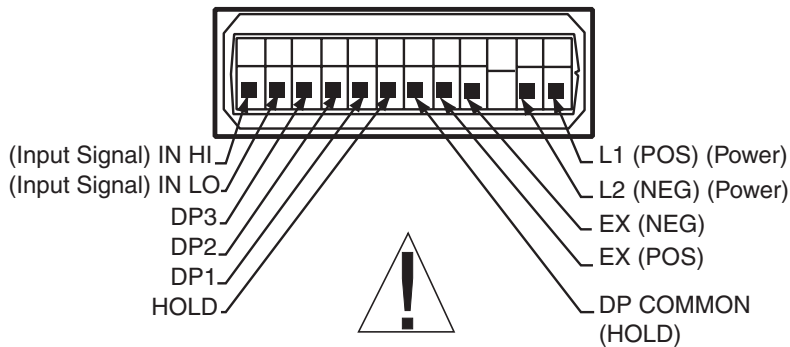

These instruments are designed for maximum safety to the operator when mounted in a panel according to instructions. They are not to be used unmounted or for exploratory measurements in unknown circuits.

- Decimal Point:** To select a decimal point, connect the appropriate DP pin (DP1, DP2, or DP3) to the DP COMMON (HOLD). Unused DP inputs may remain unconnected (open).
- Display Hold:** Connect HOLD to DP COMMON (HOLD). If this feature is not required, the DP COMMON (HOLD) pin may remain unconnected (open).
- Input Signal:** Connect the IN HI and IN LO to the signal to be monitored.
- Input Power:** Connect power to the L1 and L2 terminals. For AC powered units, L1 and L2 are not polarized. **For 9-32 DC powered units, L1 must be positive with respect to L2.**

# Display Scaling

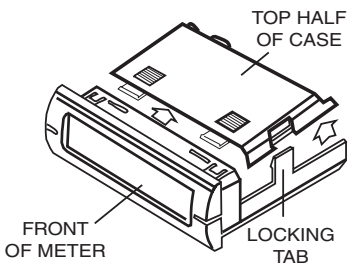

Using a screwdriver or thumbnail, spread tab on each side of case to unlock top half. Lift rear top half and slide away from front of meter.

Mini-Max indicators have limited range coarse and fine adjustments for display scaling. There are no optional connections required for these to function. The "coarse" calibration R12 will allow a limited range of scaling values. The meter can be scaled down to 1/2 the value of the input or scaled up to 2 times the value of the input or a maximum reading of 1.999, whichever is lower. Example: a 2 AMP input has a maximum reading of 1.999 counts, so you cant double the 2 AMPs, but you can make 1 AMP read 1.999. The "fine" calibration R9 allows for an approximate range of 1% of the "coarse" calibration. Apply full scale input to the meter. Adjust R12 to be within 1% of the desired scaled value, then use R9 to obtain the final desired result.

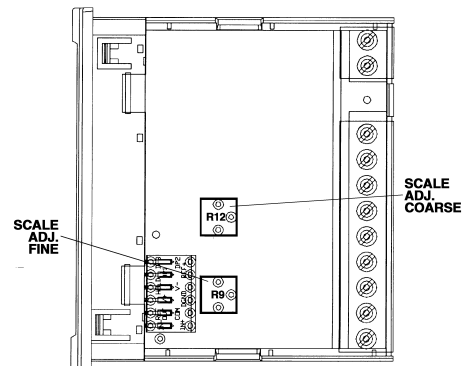

**Note:** Any physical damage to the meter during calibration will void the warranty

## Stacking Features

The mounting brackets, included with every Mini-Max, can be connected together. Multiple units can be mounted in a single opening, allowing perfect alignment.

To punch one hole for multiple units, be sure to adjust the standard panel cutout dimensions as shown here; otherwise the meters will not fit properly in the hole.

Mounting multiple units is quick and easy. Install the first meter (bottom unit first if stacking vertically). Position the next mounting bracket snugly against the first one, and slide the second meter into place. Repeat for remaining units.

### Vertical

Standard cutout

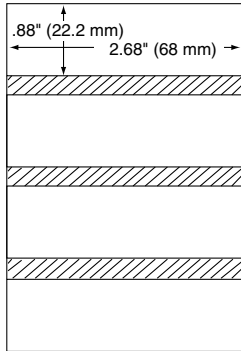

.071" (1.8 mm)  
Add to standard  
when stacking

### Vertical

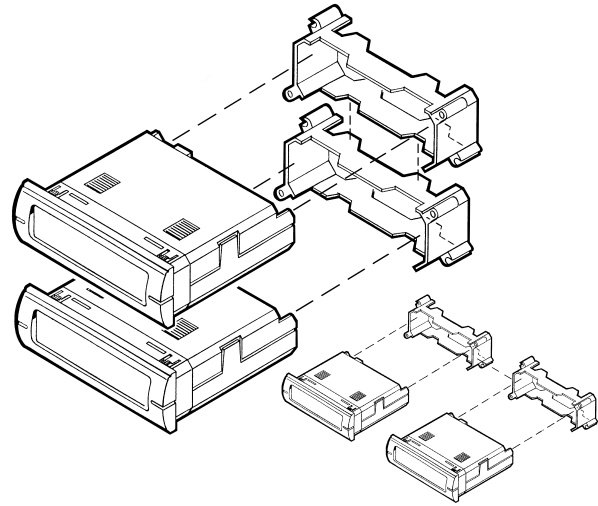

### Horizontal

### Horizontal

Standard cutout



.16" (4.0mm)  
Add to standard when stacking

## Backlight Option and Decimal Point Selection

Negative image, bright red backlighting is available in the Mini-Max. This illumination allows the unit to be read in low light areas. Backlighting power is supplied by the Mini-Max, so no additional external power is required.

Decimal point selection is accomplished by connecting the appropriate DP terminal to the DP Common terminal.

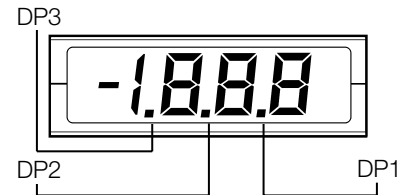
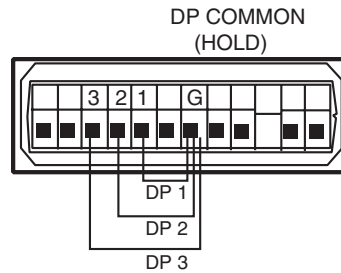

## Excitation Output

Excitation output is available in the Mini-Max for powering external transmitters or transducers. Excitation is available from the EX POS and EX NEG terminals. This source is isolated from the measurement input as well as the input power circuits. The voltages available are 12VDC or 24VDC, with a maximum load current of 25 millamps. This feature eliminates the need to mount an external DC power source for transducers or sensors used in your application.

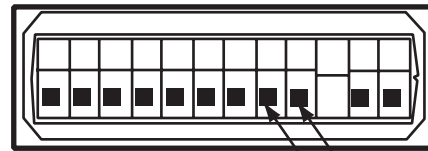

EX NEG  
EX POS



Do not exceed an excitation  
load current of 25mA!

