

D2AW

Sealed Ultra Subminiature Basic Switch

Long stroke seal switch with high reliability and high insulation performance

- <Clipping contact> Double reliability by twin contacts (=Clipping contact). Foreign materials are cleaned out by the sliding contacts.
- <Quiet operation> Quiet operating sound by sliding contact construction is needed for high grade car.
- <High insulation performance> High performance of Insulation resistance by unique contact structure.

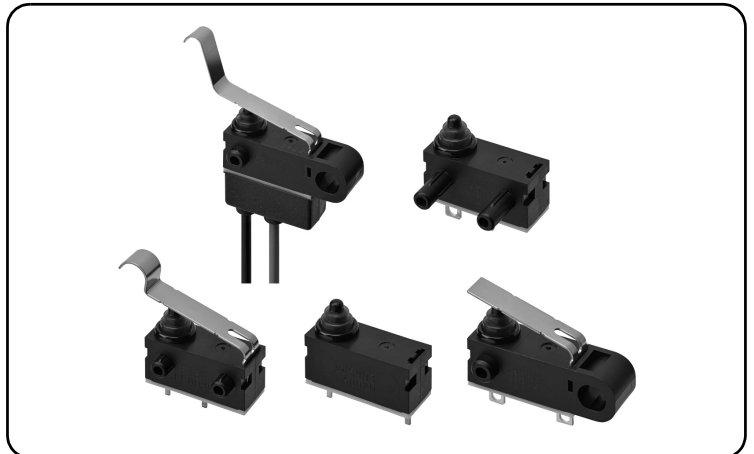

Model Number Legend

D2AW-□□□□□□-□

1 2 3 4 5 6

1. Mounting Structure

- A: Without posts
- BR: Long post on right
- BL: Long post on left
- C: M3-screw mounting model
- ER: Short post on right
- EL: Short post on left

2. Ratings

- 0: 0.1 A at 12 VDC

3. Actuator

- 0: Pin plunger
- 5: Long straight leaf lever
- 6: Leaf lever
- 7: Simulated roller leaf lever
- 8: Long leaf lever

4. Contact Form

- 2: SPST-NC
- 3: SPST-NO

5. Terminals

- D: Straight PCB terminals
- H: Solder terminals
- M: Molded lead wires downwards
- MR: Molded lead wires on right-side
- ML: Molded lead wires on left-side

6. Option Code

- Customized Code

List of Models

Due to the idiosyncrasies of the automotive parts industry, a business decision is required on individual items to determine when to start supply. Contact your OMRON representative for information on individual models.

Actuator	Terminals	Model	Without posts	Long post on right	Long post on left	M3-screw mounting model	Short post on right	Short post on left
		Contact Form						
	Solder terminals	SPST-NC	D2AW-A002H	D2AW-BR002H	D2AW-BL002H	D2AW-C002H	D2AW-ER002H	D2AW-EL002H
		SPST-NO	D2AW-A003H	D2AW-BR003H	D2AW-BL003H	D2AW-C003H	D2AW-ER003H	D2AW-EL003H
	PCB terminals	SPST-NC	D2AW-A002D	D2AW-BR002D	D2AW-BL002D	D2AW-C002D	D2AW-ER002D	D2AW-EL002D
		SPST-NO	D2AW-A003D	D2AW-BR003D	D2AW-BL003D	D2AW-C003D	D2AW-ER003D	D2AW-EL003D
	Molded lead wires (Downwards)	SPST-NC	---	D2AW-BR002M	D2AW-BL002M	D2AW-C002M	---	---
		SPST-NO	---	D2AW-BR003M	D2AW-BL003M	D2AW-C003M	---	---
	Solder terminals	SPST-NC	D2AW-A052H	D2AW-BR052H	D2AW-BL052H	D2AW-C052H	D2AW-ER052H	D2AW-EL052H
		SPST-NO	D2AW-A053H	D2AW-BR053H	D2AW-BL053H	D2AW-C053H	D2AW-ER053H	D2AW-EL053H
	PCB terminals	SPST-NC	D2AW-A052D	D2AW-BR052D	D2AW-BL052D	D2AW-C052D	D2AW-ER052D	D2AW-EL052D
		SPST-NO	D2AW-A053D	D2AW-BR053D	D2AW-BL053D	D2AW-C053D	D2AW-ER053D	D2AW-EL053D
	Molded lead wires (Downwards)	SPST-NC	---	D2AW-BR052M	D2AW-BL052M	D2AW-C052M	---	---
		SPST-NO	---	D2AW-BR053M	D2AW-BL053M	D2AW-C053M	---	---
	Solder terminals	SPST-NC	D2AW-A062H	D2AW-BR062H	D2AW-BL062H	D2AW-C062H	D2AW-ER062H	D2AW-EL062H
		SPST-NO	D2AW-A063H	D2AW-BR063H	D2AW-BL063H	D2AW-C063H	D2AW-ER063H	D2AW-EL063H
	PCB terminals	SPST-NC	D2AW-A062D	D2AW-BR062D	D2AW-BL062D	D2AW-C062D	D2AW-ER062D	D2AW-EL062D
		SPST-NO	D2AW-A063D	D2AW-BR063D	D2AW-BL063D	D2AW-C063D	D2AW-ER063D	D2AW-EL063D
	Molded lead wires (Downwards)	SPST-NC	---	D2AW-BR062M	D2AW-BL062M	D2AW-C062M	---	---
		SPST-NO	---	D2AW-BR063M	D2AW-BL063M	D2AW-C063M	---	---
	Solder terminals	SPST-NC	D2AW-A072H	D2AW-BR072H	D2AW-BL072H	D2AW-C072H	D2AW-ER072H	D2AW-EL072H
		SPST-NO	D2AW-A073H	D2AW-BR073H	D2AW-BL073H	D2AW-C073H	D2AW-ER073H	D2AW-EL073H
	PCB terminals	SPST-NC	D2AW-A072D	D2AW-BR072D	D2AW-BL072D	D2AW-C072D	D2AW-ER072D	D2AW-EL072D
		SPST-NO	D2AW-A073D	D2AW-BR073D	D2AW-BL073D	D2AW-C073D	D2AW-ER073D	D2AW-EL073D
	Molded lead wires (Downwards)	SPST-NC	---	D2AW-BR072M	D2AW-BL072M	D2AW-C072M	---	---
		SPST-NO	---	D2AW-BR073M	D2AW-BL073M	D2AW-C073M	---	---
	Molded lead wires (Downwards)	SPST-NC	---	D2AW-BR082M	D2AW-BL082M	D2AW-C082M	---	---
		SPST-NO	---	D2AW-BR083M	D2AW-BL083M	D2AW-C083M	---	---

Contact Specifications

Contact	Specification	Slide
	Material	Silver Plated
Minimum applicable load (see note)		5 VDC 1 mA

Note: For more information on the minimum applicable load, refer to *Using Micro Loads*.

Ratings

Rating voltage	Resistive load
12 VDC	0.1 A

Note: The rating values apply under the following test conditions.

1. Ambient temperature: 20 ± 2°C
2. Ambient humidity: 65 ± 5%
3. Operating frequency: 20 operations/min

Characteristics

Permissible operating speed		30 mm to 500 mm/s (pin plunger models)
Permissible operating frequency	Mechanical	30 operations/min max.
	Electrical	20 operations/min max.
Insulation resistance		100 MΩ min. (at 500 VDC)
Contact resistance (initial value)	Terminals	100 mΩ max.
	Molded lead wires models	150 mΩ max.
Dielectric strength	Between terminals of the same polarity	600 VAC 50/60 Hz 1min
	Between current-carrying metal parts and ground	1,500 VAC 50/60 Hz 1min
	Between terminals and non-current-carrying metal parts	1,500 VAC 50/60 Hz 1min
Vibration resistance *1	Malfunction	10 to 55 Hz, 1.5 mm double amplitude
Shock resistance *1	Destruction	1,000 m/s ² max.
	Malfunction	300 m/s ² max.
Durability *2	Mechanical	200,000 operations min. (30 operations/min)
	Electrical	200,000 operations min. (20 operations/min)
Degree of protection		IEC IP67
Ambient operating temperature		-40 to 85°C (at 60%RH max.) (with no icing or condensation)
Ambient operation humidity		95%RH max. (for +5 to +35°C)
Weight		Approx. 0.7 g (for pin plunger models with terminals)

Note: The data given above are initial values.

*1. For the pin plunger models, the above values apply for use at the free position, operating position, and total travel position. For the lever models, they apply at the total travel position. Close or open circuit of the contact is 1ms max.

*2. For testing conditions, consult your OMRON sales representative.

Mounting Structure and Reference Positions for Operating Characteristics (Unit: mm)

● Without posts

D2AW-A□

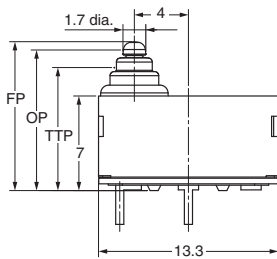

● Short post

D2AW-E□

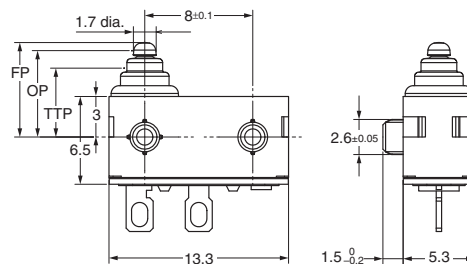

Mounting Hole Dimensions (Reference)

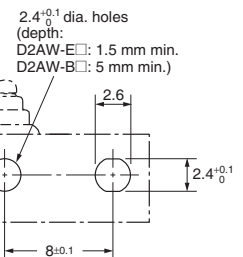

● Long post

D2AW-B□

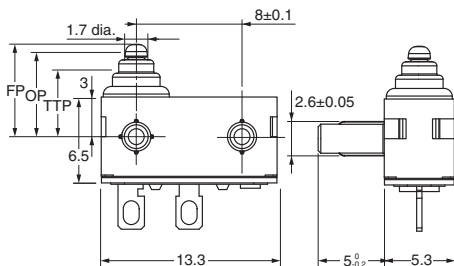

● M3-screw Mounting Models

D2AW-C□

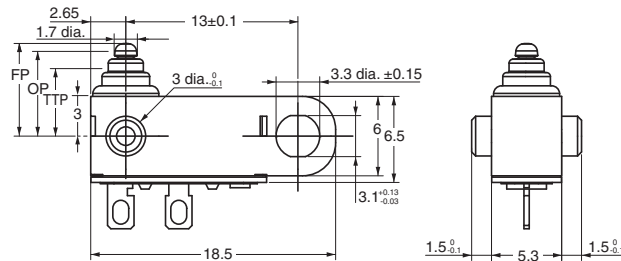

Terminals (Unit: mm)

● PCB terminals

SPST-NO

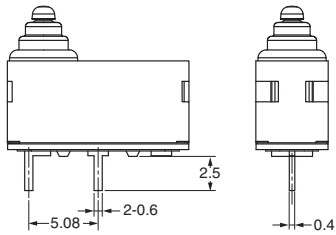

SPST-NC

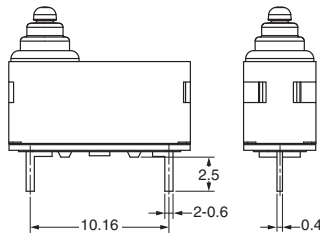

<PCB Mounting Dimensions (Reference)>

SPST-NO

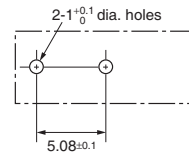

SPST-NC

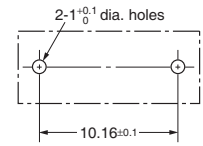

● Solder terminals

SPST-NO

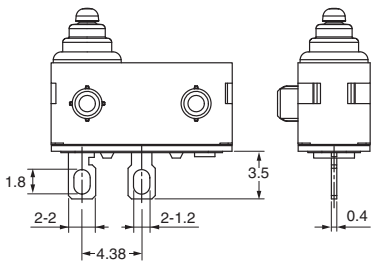

SPST-NC

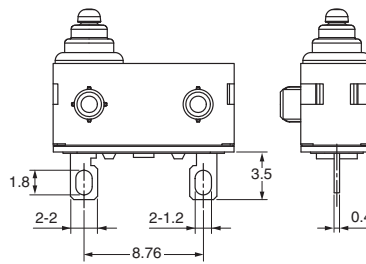

● Molded Lead Wires on Left-side

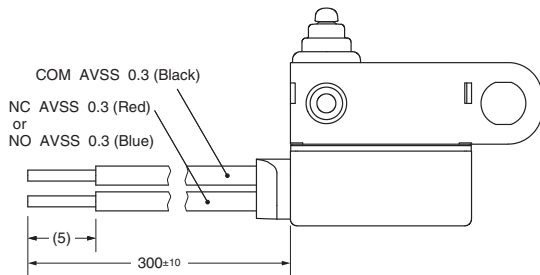

● Molded Lead Wires on Right-side

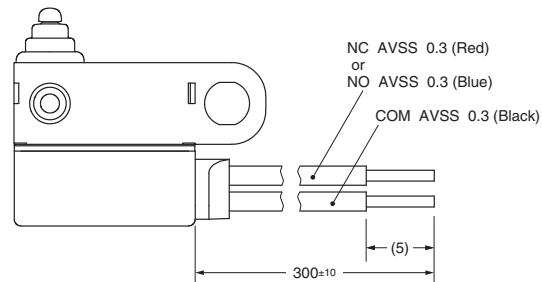

● Molded Lead Wires Downwards (NO)

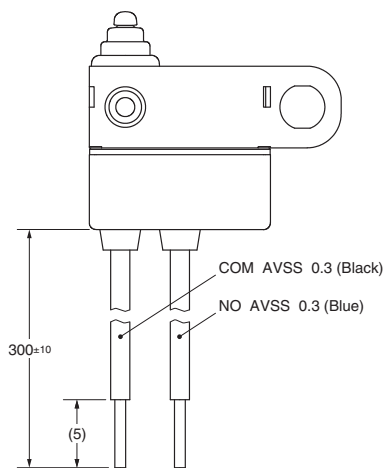

● Molded Lead Wires Downwards (NC)

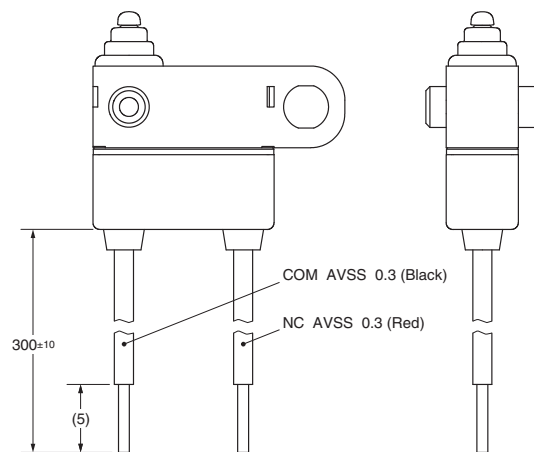

Dimensions (Unit: mm) / Operating Characteristics

The following illustrations and drawings are for solder terminal models. PCB terminal models are omitted from the drawings. Refer to *Terminals* for these terminals. When ordering, replace □ with the code for the rating that you need. For the combination of models, refer to *List of Models*.

● Pin plunger

D2AW-□00□□

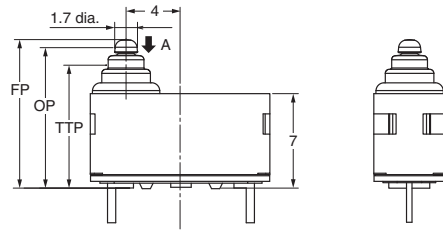

Operating characteristics	Type	Without posts	Models with Posts	M3-screw Mounting Models
Operating Force	OF Max.	1.00N {101 gf}		
Releasing Force	RF Min.	0.10N {10 gf}		
Overtravel	OT	1.4 mm (reference value)		
Movement Differential	MD Max.	0.25 mm		
Free Position	FP Max.	11.2 mm	7.2 mm	
Operating Position	OP	10.4 ± 0.3 mm	6.4 ± 0.3 mm	
Total Travel Position	TTP	9.1 mm	5.1 mm	

● Long straight leaf lever

D2AW-□05□□

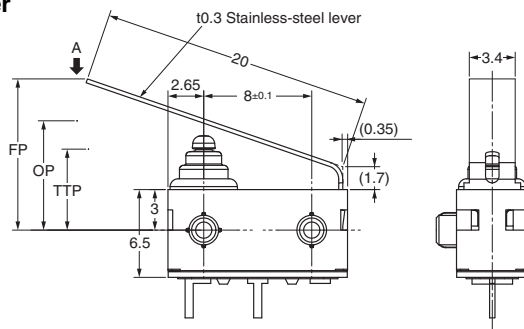

Operating characteristics	Type	Without posts	Models with Posts	M3-screw Mounting Models
Operating Force	OF Max.	1.50N {152 gf}		
Releasing Force	RF Min.	0.10N {10 gf}		
Overtravel	OT	2.5 mm (reference value)		
Movement Differential	MD Max.	0.7 mm		
Free Position	FP Max.	15.9 mm	11.9 mm	
Operating Position	OP	12.1 ± 0.8 mm	8.1 ± 0.8 mm	
Total Travel Position	TTP	10.0 mm	6.0 mm	

● Leaf lever

D2AW-□06□□

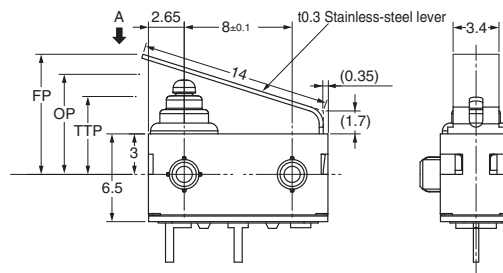

Operating characteristics	Type	Without posts	Models with Posts	M3-screw Mounting Models
Operating Force	OF Max.	2.00N {203 gf}		
Releasing Force	RF Min.	0.20N {20 gf}		
Overtravel	OT	1.8 mm (reference value)		
Movement Differential	MD Max.	0.5 mm		
Free Position	FP Max.	13.3 mm	9.3 mm	
Operating Position	OP	11.4 ± 0.5 mm	7.4 ± 0.5 mm	
Total Travel Position	TTP	9.8 mm	5.8 mm	

● Simulated roller leaf lever

D2AW-□07□□

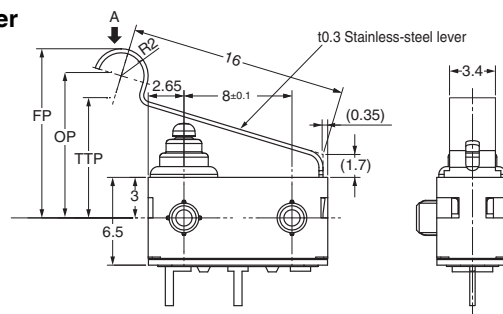

Operating characteristics	Type	Without posts	Models with Posts	M3-screw Mounting Models
Operating Force	OF Max.	1.80N {183gf}		
Releasing Force	RF Min.	0.20N {20 gf}		
Overtravel	OT	2.0 mm (reference value)		
Movement Differential	MD Max.	0.5 mm		
Free Position	FP Max.	17.0 mm	13.0 mm	
Operating Position	OP	14.8 ± 0.5 mm	10.8 ± 0.5 mm	
Total Travel Position	TTP	12.9 mm	8.9 mm	

● Simulated roller leaf lever

D2AW-□08□□

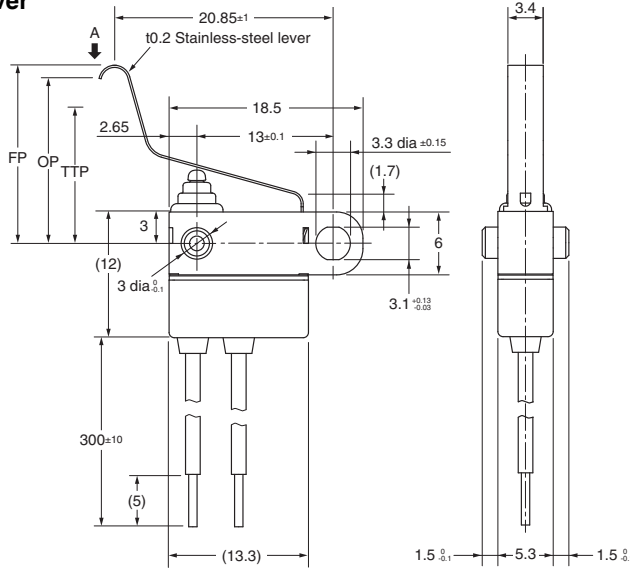

Operating characteristics	Type	Models with Posts	M3-screw Mounting Models
Operating Force	OF	Max.	0.9N {92gf}
Releasing Force	RF	Min.	0.05N {5 gf}
Overtravel	OT		2.8 mm
Movement Differential	MD	Max.	(reference value) 0.7 mm
Free Position	FP	Max.	19.0 mm
Operating Position	OP		15.4 ± 1.5 mm
Total Travel Position	TTP		12.8 mm

Note1. Unless otherwise specified, a tolerance of ± 0.2 mm applies to all dimensions.

Note2. The operating characteristics are for operation in the A direction (\downarrow).

Precautions

Please refer to "Safety Precautions for All Detection Switches" for correct use.

Cautions

●Degree of Protection

- Do not use this product underwater.

Although molded lead wire models satisfy the test conditions for the standard given below, this test is to check the ingress of water into the switch enclosure after submerging the Switch in water for a given time. Satisfying this test condition does not mean that the Switch can be used underwater.

JIS C0920:

Degrees of protection provided by enclosures of electrical apparatus (IP Code)

IEC 60529:

Degrees of protection provided by enclosures (IP Code)

Degree of protection: IP67

(check water intrusion after immersion for 30 min. submerged 1m underwater)

- Do not operate the Switch when it is exposed to water spray, or when water drops adhere to the Switch surface, or during sudden temperature changes, otherwise water may intrude into the interior of the Switch due to a suction effect.
- Prevent the Switch from coming into contact with oil and chemicals.
Otherwise, damage to or deterioration of Switch materials may result.
- Do not use the Switch in areas where it is exposed to silicon adhesives, oil, or grease. Otherwise faulty contact may result due to the generation of silicon oxide.

●Soldering

When soldering the lead wire to the terminal, first insert the lead wire conductor through the terminal hole and then conduct soldering.

Make sure that the temperature of the soldering iron tip does not exceed 300°C, and complete the soldering within 3 seconds. Do not apply any external force for 1 minute after soldering.

Soldering at an excessively high temperature or soldering for more than 3 seconds may deteriorate the characteristics of the Switch.

In case of automatic soldering, please do not apply the heat beyond 260°C within 5 seconds. Pay careful attention so that flux or solder liquid does not flow over the edge of the PCB panel.

●Side-actuated (Cam/Dog) Operation

- When using a cam or dog to operate the Switch, factors such as the operating speed, operating frequency, push-button indentation, and material and shape of the cam or dog will affect the durability of the Switch. Confirm performance specifications under actual operating conditions before using the Switch in applications.

Correct Use

●Mounting

- Turn OFF the power supply before mounting or removing the Switch, wiring, or performing maintenance or inspection. Failure to do so may result in electric shock or burning.
- For M3-screw mounting models, use M3 mounting screws with plane washers or spring washers to securely mount the Switch. Tighten the screws to a torque of 0.27 to 0.29 N·m {27.5 to 29.5 gf}. Exceeding the specified torque may result in deterioration of the sealing or damage.
- For models with posts, secure the posts by pressing into an attached device. Provide guides on the opposite ends of the posts to ensure that they do not fall out or rattle.

●Operating Body

- Use an operating body with low frictional resistance and of a shape that will not interfere with the sealing rubber, otherwise the plunger may be damaged or the sealing may deteriorate.

●Handling

- Do not handle the Switch in a way that may cause damage to the sealing rubber.
- When handling the Switch, ensure that pressure is not applied to the posts in the directions shown in the following diagram. Also, ensure that uneven pressure or pressure in a direction other than the operating direction is not applied to the Actuator as shown in the following diagram. Otherwise, the post, Actuator, or Switch may be damaged, or the service life may be reduced.

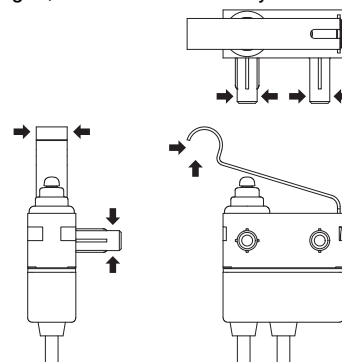

●Wiring Molded Lead Wire Models

- When wiring molded lead wire models, ensure that there is no weight applied on the wire or that there are no sharp bends near the parts where the wire is drawn out. Otherwise, damage to the Switch or deterioration in the sealing may result.

●Using Micro Loads

- Even when using micro load models within the operating range, if inrush/surge current occurs, it may increase the contact wear and so decrease durability. Therefore, insert a contact protection circuit where necessary.