

# SNAP I/O Racks

## Features

- Secure mounting for SNAP I/O modules plus a SNAP brain or on-the-rack SNAP controller
- Analog, digital, and serial modules on the same rack
- Panel or DIN-rail mounting
- Modules snap into place

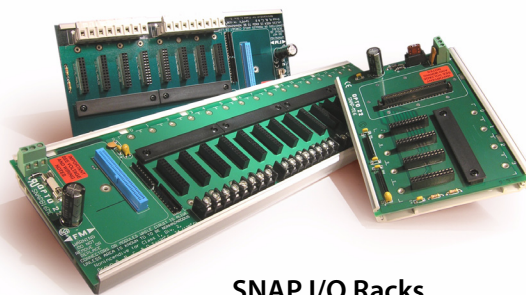

SNAP I/O Racks

## Description

SNAP I/O mounting racks are designed to hold an intelligent SNAP I/O processor—either a SNAP brain or an on-the-rack controller—and several I/O modules.

This rack family includes racks that are compatible with Ethernet-based SNAP PAC R-series and SNAP Ultimate I/O™ on-the-rack controllers, with Ethernet-based SNAP Ethernet I/O™ and SNAP Simple I/O™ brains, and with ARCNET and serial SNAP brains, including those using Modbus® and Profibus® protocols. For specific processor compatibility, see “Specifications” on page 3.

Since SNAP analog, digital, and serial I/O modules have the same footprint, customers using most SNAP I/O racks can mix modules on the same I/O mounting rack. However, module types, features, and positions on the rack vary depending on the capabilities of the brain or on-the-rack controller used. See the brain or controller data sheet for details.

Field devices are wired directly to the top-mounted removable connectors on the modules plugged into each rack. SNAP I/O racks can accommodate up to 4, 8, 12, or 16 modules. The module and rack design allows modules to simply “snap” on and off the mounting rack.

SNAP racks use a retention rail locking system that holds modules securely to the rack. Normally, a hold-down screw is not required. However, for applications that require additional module security, SNAP racks have provisions for two 4-40 by ½-inch standard machine screws to hold each module in position.

MC and MC-P model racks provide an auxiliary screw-type terminal strip for field wiring common connections such as loop power distribution. MC racks use a fixed terminal strip, while MC-P racks use removable connectors for easy maintenance (see enlarged view on the following page).

All SNAP racks offer panel mounting and the option of DIN-rail mounting. SNAP racks require a 5 VDC power source.

SNAP-B4M, SNAP-B8M, SNAP-B12M, SNAP-B16M, and SNAP-D64RS racks are Factory Mutual approved.

## Part Numbers

Part	Description
SNAP-M16	4-module rack for SNAP PAC R-series, SNAP-UP1-M64, and SNAP-ENET-S64
SNAP-M32	8-module rack for SNAP PAC R-series, SNAP-UP1-M64, and SNAP-ENET-S64
SNAP-M48	12-module rack for SNAP PAC R-series, SNAP-UP1-M64, and SNAP-ENET-S64
SNAP-M64	16-module rack for SNAP PAC R-series, SNAP-UP1-M64, and SNAP-ENET-S64
SNAP-B4M*	4-module rack for other brains
SNAP-B8M*	8-module rack for other brains
SNAP-B12M*	12-module rack for other brains
SNAP-B16M*	16-module rack for other brains
SNAP-B8MC	8-module rack for other brains, with extra terminal block for field wiring
SNAP-B12MC	12-module rack for other brains, with extra terminal block for field wiring
SNAP-B16MC	16-module rack for other brains, with extra terminal block for field wiring
SNAP-B8MC-P	8-module rack for other brains, with extra terminal block for field wiring, pluggable
SNAP-B12MC-P	12-module rack for other brains, with extra terminal block for field wiring, pluggable
SNAP-B16MC-P	16-module rack for other brains, with extra terminal block for field wiring, pluggable
SNAP-D64RS*	16-module rack for digital-only SNAP Ultimate, SNAP Ethernet, and SNAP-PDPRS64 Profibus brains
SNAP-FUSE7.5AB	7.5-amp fuse, 25-pack
SNAP-FUSE4AB	4-amp fuse, 25-pack
SNAP-FUSE1AB	1-amp fuse, 25-pack
SNAP-RACKDIN	SNAP rack DIN-rail adapter clip
SNAPRACKDINB	SNAP rack DIN-rail adapter clip, 25-pack

\* Factory Mutual (FM) approved

**Description (continued)**

**SNAP-M32 (8-Module Position I/O Mounting Rack)**

Shown with SNAP-PAC-R1 controller (purchased separately)

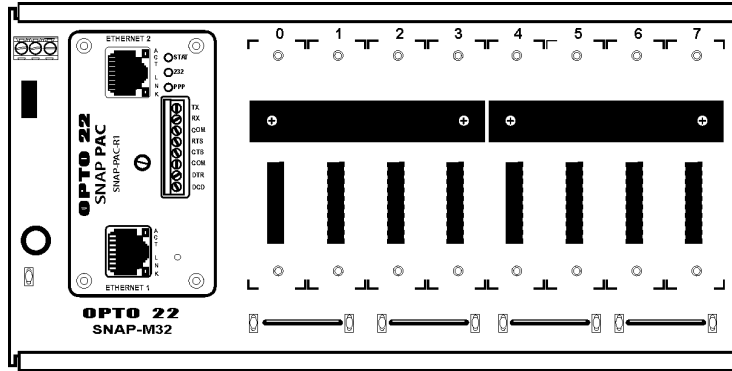

**SNAP-B8M (8-Module Position I/O Mounting Rack)**

Shown with B3000 brain (purchased separately)

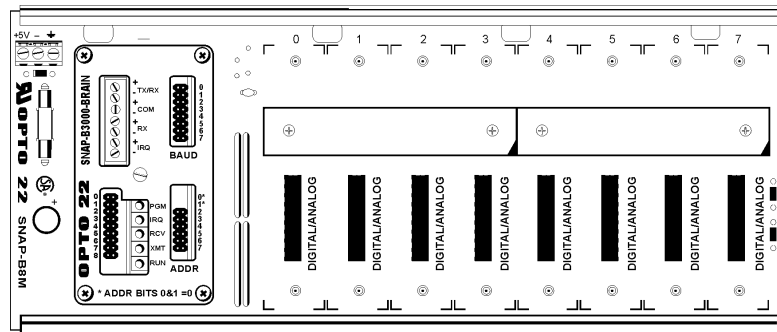

**SNAP-B8MC (8-Module Position I/O Mounting Rack)**

Shown with B3000 brain (purchased separately)

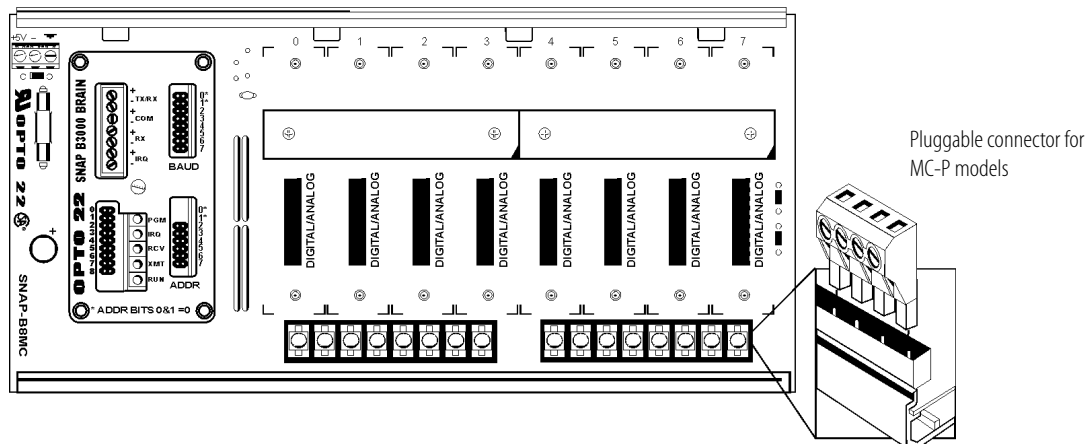

# SNAP I/O Racks

## Specifications

Part Number	Description <sup>1</sup>	Power <sup>2</sup> Requirements	I/O Processor <sup>3</sup> Compatibility	Replacement Fuse	Operating Temperature	Relative Humidity
SNAP-M16	4-module mixed <sup>4</sup>	5.0 to 5.2 VDC @ 4.2 Amps max	SNAP-PAC-R1 SNAP-PAC-R2 SNAP-UP1-M64 SNAP-ENET-S64	SNAP- FUZE7.5AB or Littelfuse <sup>6</sup> 297 07.5	0° to 70° C	95%, non- condensing
SNAP-M32	8-module mixed <sup>4</sup>					
SNAP-M48	12-module mixed <sup>4</sup>					
SNAP-M64	16-module mixed <sup>4</sup>					
SNAP-B4M	4-module mixed	5.0 to 5.2 VDC @ 1.8 Amps max	SNAP-UP1-ADS SNAP-B3000-ENET SNAP-ENET-RTC B3000 B3000-HA SNAP-B4 SNAP-B6 SNAP-BRS SNAP-BRS-HA SNAP-B3000- MODBUS	SNAP-FUZE4A or Bel <sup>6</sup> 5HF4		
SNAP-B8M	8-module mixed	5.0 to 5.2 VDC @ 2.6 Amps max				
SNAP-B8MC	8-module mixed, terminal block					
SNAP-B8MC-P	8-module mixed, pluggable terminal block					
SNAP-B12M	12-module mixed <sup>5</sup>	5.0 to 5.2 VDC @ 3.4 Amps max				
SNAP-B12MC	12-module mixed <sup>5</sup> , terminal block					
SNAP-B12MC-P	12-module mixed <sup>5</sup> , pluggable terminal block					
SNAP-B16M	16-module mixed <sup>5</sup>	5.0 to 5.2 VDC @ 4.2 Amps max				
SNAP-B16MC	16-module mixed <sup>5</sup> , terminal block					
SNAP-B16MC-P	16-module mixed <sup>5</sup> , pluggable terminal block					
SNAP-D64RS	16-module digital only (limited digital functions)	5.0 to 5.2 VDC @ 1.8 Amps max	SNAP-UP1-D64 SNAP-ENET-D64 SNAP-PDPRS64	SNAP-FUZE1A or Buss <sup>6</sup> GDC1A		

<sup>1</sup> "Mixed" means the rack can hold analog, digital, and serial modules. Most Ethernet-based I/O processors handle all these types of modules; other processors do not. See the processor's data sheet for details.

<sup>2</sup> Power requirements shown are for a rack, a processor, and a full load of 2-channel analog modules (for the SNAP-D64RS, a full load of 4-channel digital modules). Power requirements for other SNAP modules are higher. See module data sheets.

<sup>3</sup> "I/O Processor" means a SNAP brain or on-the-rack controller.

<sup>4</sup> Digital features and module positions depend on processor. SNAP-PAC-R1 supports full digital features (high-speed counting, quadrature counting, TPO, pulsing), but on larger racks, 4-channel SNAP digital modules must be in positions 0–7 only (32-channel digital modules can be in any position). SNAP-PAC-R2, SNAP-UP1-M64, and SNAP-ENET-S64 offer more limited digital features but can use digital modules in any position. See the processor's data sheet for details.

<sup>5</sup> Four-channel SNAP digital modules can be used in positions 0–7 only.

<sup>6</sup> Manufacturer's part number (not available through Opto 22).

### Specifications (continued)

**All models:**  
**Power schematic**  
 For fuse part numbers, see Specifications on [page 3](#).

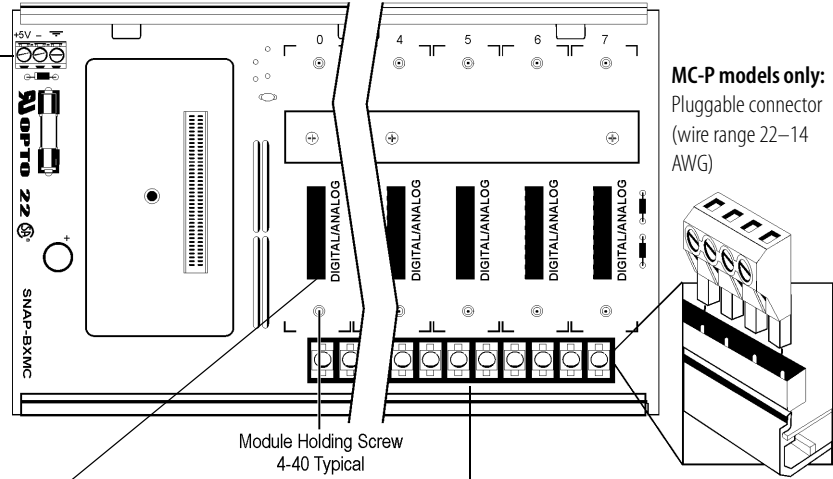
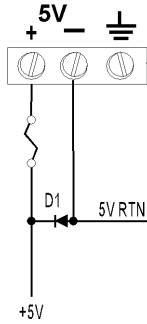

**MC-P models only:**  
 Pluggable connector  
 (wire range 22-14  
 AWG)

**All models:** Module mating connector pinout (female)

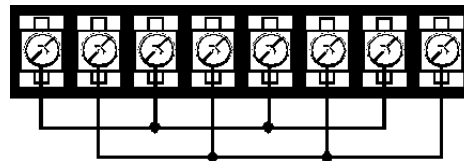
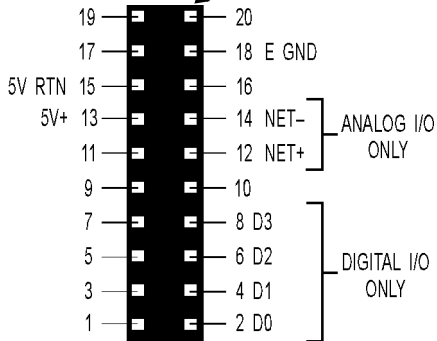

**MC and MC-P models only:** For detailed information on terminal strip usage, see [page 12](#) through [page 16](#).

# SNAP I/O Racks

## Dimensional Drawings

### Dimensions—M-Series Racks, SNAP-D64RS Rack, and B-Series Racks with Terminal Strips

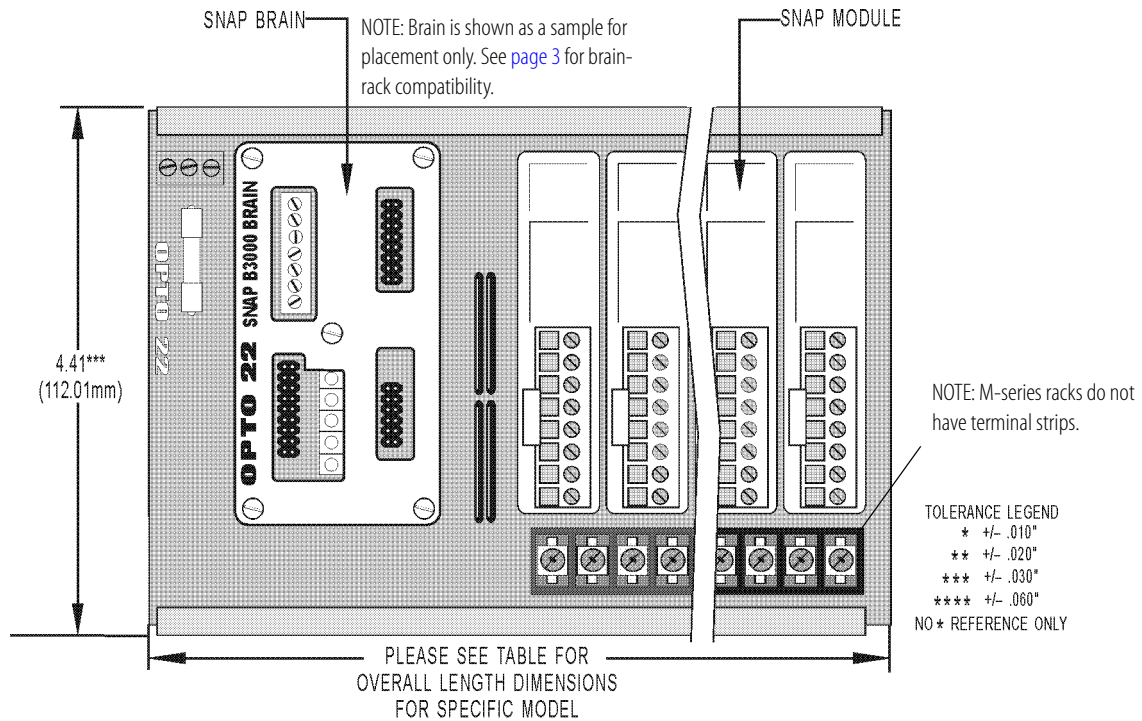

### Overall Length Dimensions (M-series, SNAP-D64RS, and B-series racks with terminal strips)

Part Number	Description	Width (inches)	Width (mm)	Length (inches)	Length (mm)
SNAP-M16	4-module rack for SNAP PAC R-series, SNAP-UP1-M64, SNAP-ENET-S64	4.41	112.01	6.25	158.75
SNAP-M32	8-module rack for SNAP PAC R-series, SNAP-UP1-M64, SNAP-ENET-S64	4.41	112.01	9.25	234.95
SNAP-M48	12-module rack for SNAP PAC R-series, SNAP-UP1-M64, SNAP-ENET-S64	4.41	112.01	12.25	311.15
SNAP-M64	16-module rack for SNAP PAC R-series, SNAP-UP1-M64, SNAP-ENET-S64	4.41	112.01	15.25	387.35
SNAP-B8MC SNAP-B8MC-P	8-module rack for other brains, with terminal block	4.41	112.01	9.25	234.95
SNAP-B12MC SNAP-B12MC-P	12-module rack for other brains, with terminal block	4.41	112.01	12.25	311.15
SNAP-B16MC SNAP-B16MC-P	16-module rack for other brains, with terminal block	4.41	112.01	15.25	387.35
SNAP-D64RS	16-module rack, digital only	4.41	112.01	15.25	387.35

### Dimensional Drawings (continued)

#### Dimensions—B-Series Racks Without Terminal Strips

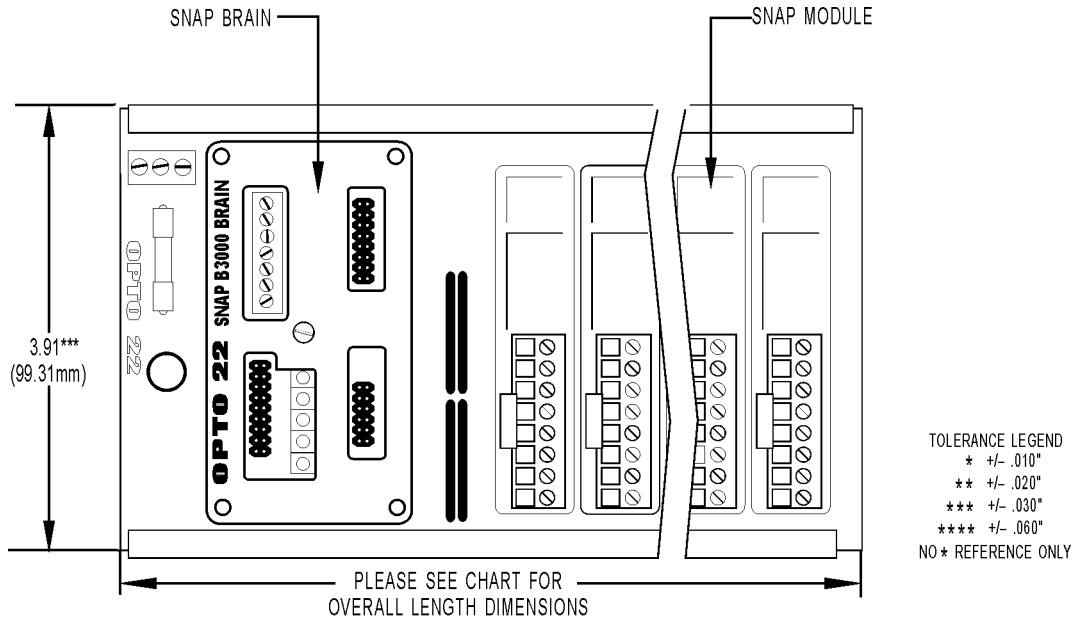

#### Overall Length Dimensions (B-series racks without terminal strips)

Part Number	Description	Width (inches)	Width (mm)	Length (inches)	Length (mm)
SNAP-B4M	4-module rack	3.91	99.31	6.24	158.41
SNAP-B8M	8-module rack	3.91	99.31	9.24	234.70
SNAP-B12M	12-module rack	3.91	99.31	12.24	310.90
SNAP-B16M	16-module rack	3.91	99.31	15.24	387.10

# SNAP I/O Racks

## Dimensional Drawings (continued)

### M-Series Racks, SNAP-D64RS Rack, and B-Series Racks with Terminal Strips: Right Side View with DIN-Rail Option Installed

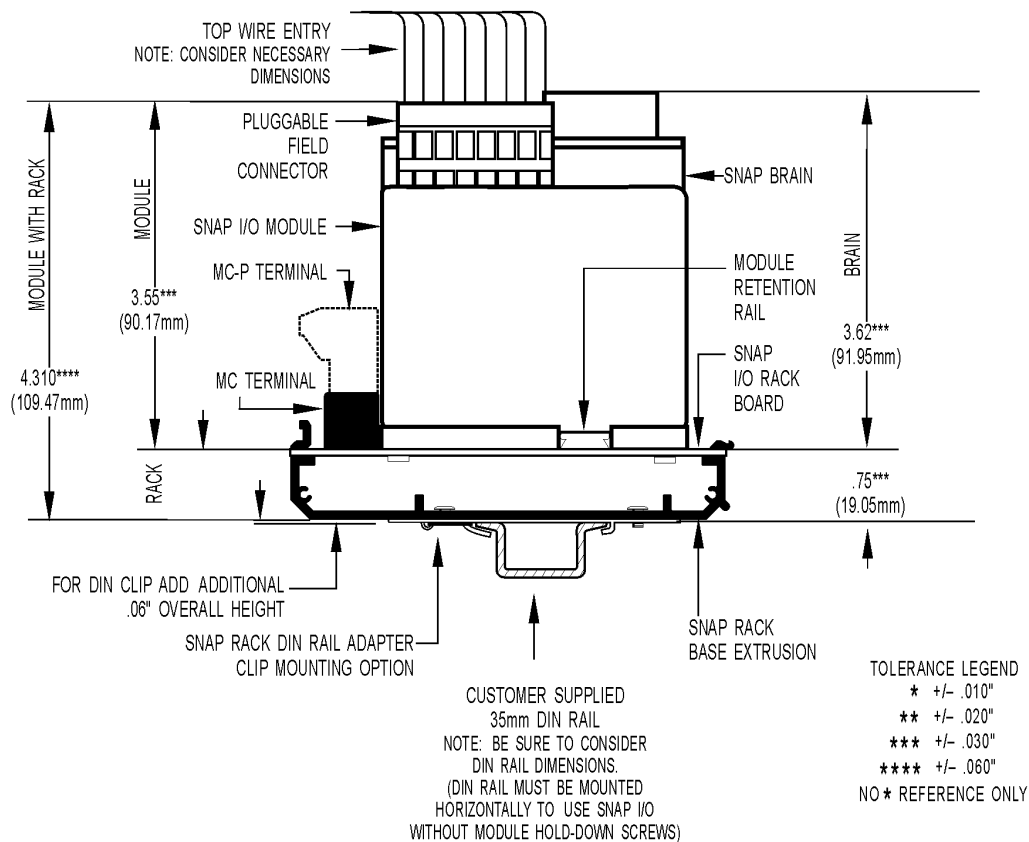

Processor Height*	Processor Part Number	Rack
4.12 in. (104.6 mm)	SNAP-PAC-R1 SNAP-PAC-R2 SNAP-ENET-S64 SNAP-UP1-M64	M-series
	SNAP-UP1-ADS SNAP-B3000-ENET SNAP-ENET-RTC	B-series
	SNAP-UP1-D64 SNAP-ENET-D64	SNAP-D64RS
3.70 in. (95.9 mm)	B3000      B3000-HA SNAP-B4    SNAP-BRS-HA SNAP-B6    SNAP-B3000-MODBUS SNAP-BRS	B-series

\* Height listed is from the processor's mounting surface to the highest part of the processor. Height does not include wiring or cables.

## Dimensional Drawings (continued)

### B-Series Racks Without Terminal Strips: Right Side View with DIN-Rail Option Installed

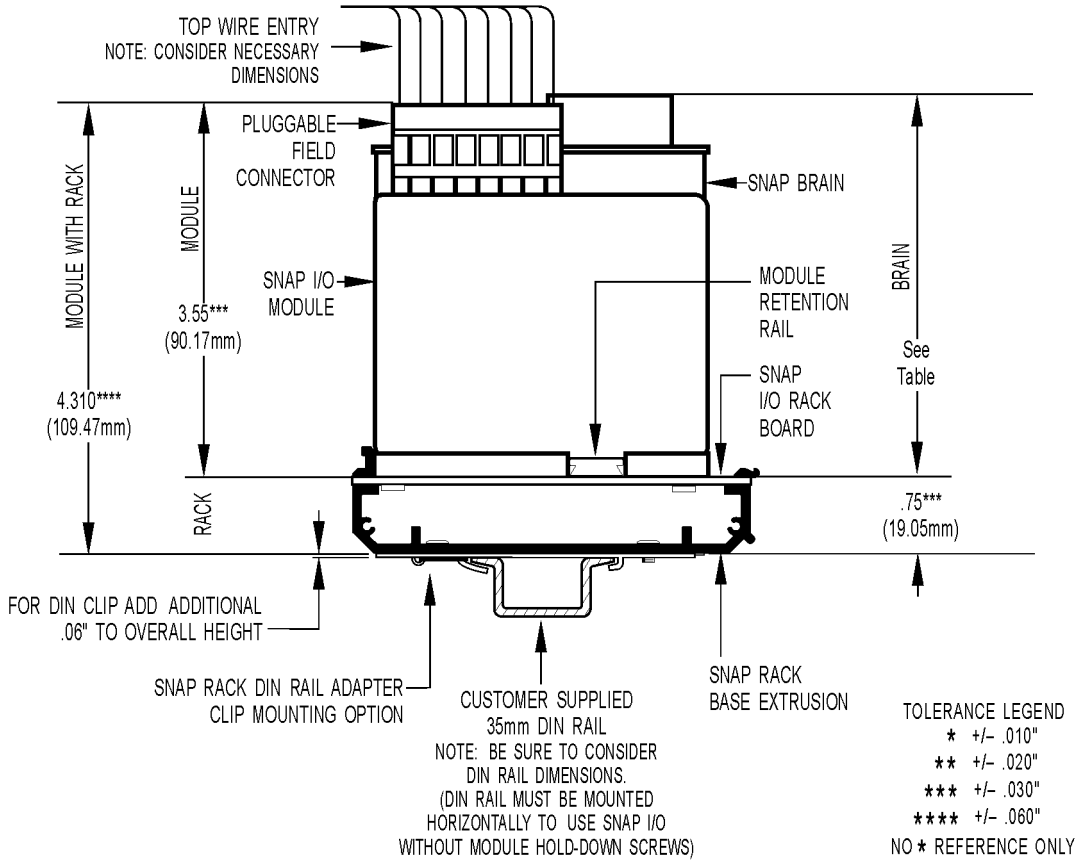

Processor Height*	Processor Part Number	
4.12 in. (104.6 mm)	SNAP-UP1-ADS SNAP-B3000-ENET	SNAP-ENET-RTC
3.70 in. (95.9 mm)	B3000 SNAP-B4 SNAP-B6 B3000-HA	SNAP-BRS SNAP-BRS-HA SNAP-B3000-MODBUS

\* Height listed is from the processor's mounting surface to the highest part of the processor. It does not include wiring or cables.

# SNAP I/O Racks

## Mounting

NOTE: If you are not using hold-down screws, the SNAP rack assembly should be mounted horizontally.

Use the following steps to mount racks as shown in the diagrams on the next two pages.

### Preferred Method: Template

(Product on site)

1. Use SNAP rack mounting extrusion as template.
2. Be sure to use the diagrams on the next two pages to determine required product and option clearances.

### Alternate Method: Prefabrication of Panels

(No product on site)

Mounting holes are in sets of two, located on lower left and upper right with respect to a center line (CL).

1. Using the diagrams on the next two pages, determine CL1 mounting hole positions. (CL1 is located on the left side of all SNAP rack mounting extrusions.)
2. Use the center-to-center length specification table below to determine the offset between center lines and the number of center line positions for each model.
3. Repeat the process for each center line position.

### Center-to-Center Length (All Models)

Part Number	Description	Center-to-Center Length	Number of Center Positions
SNAP-M16	4-module rack	3.51 in.	2
SNAP-B4M	4-module rack	4.01 in.	2
SNAP-M32 SNAP-B8M SNAP-B8MC SNAP-B8MC-P	8-module rack	3.51 in.	3
SNAP-M48 SNAP-B12M SNAP-B12MC SNAP-B12MC-P	12-module rack	5.01 in.	3
SNAP-M64 SNAP-B16M SNAP-B16MC SNAP-B16MC-P SNAP-D64RS	16-module rack	4.34 in.	4

## Mounting (continued)

M-Series Racks, SNAP-D64RS Rack, and B-Series Racks with Terminal Strips:  
 Typical Plain View of SNAP Mounting Extrusion

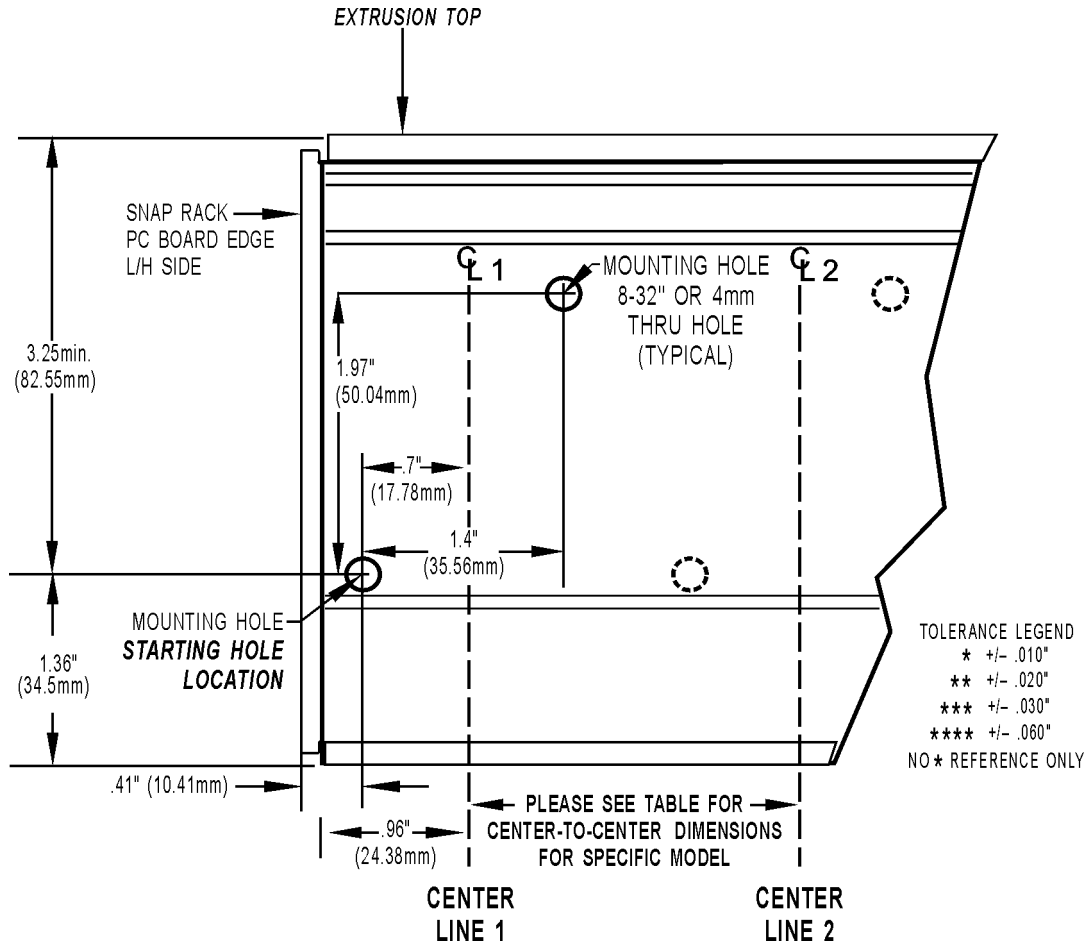

See instructions and table on [page 9](#).

# SNAP I/O Racks

## Mounting (continued)

### B-Series Racks Without Terminal Strips: Typical Plain View of SNAP Mounting Extrusion

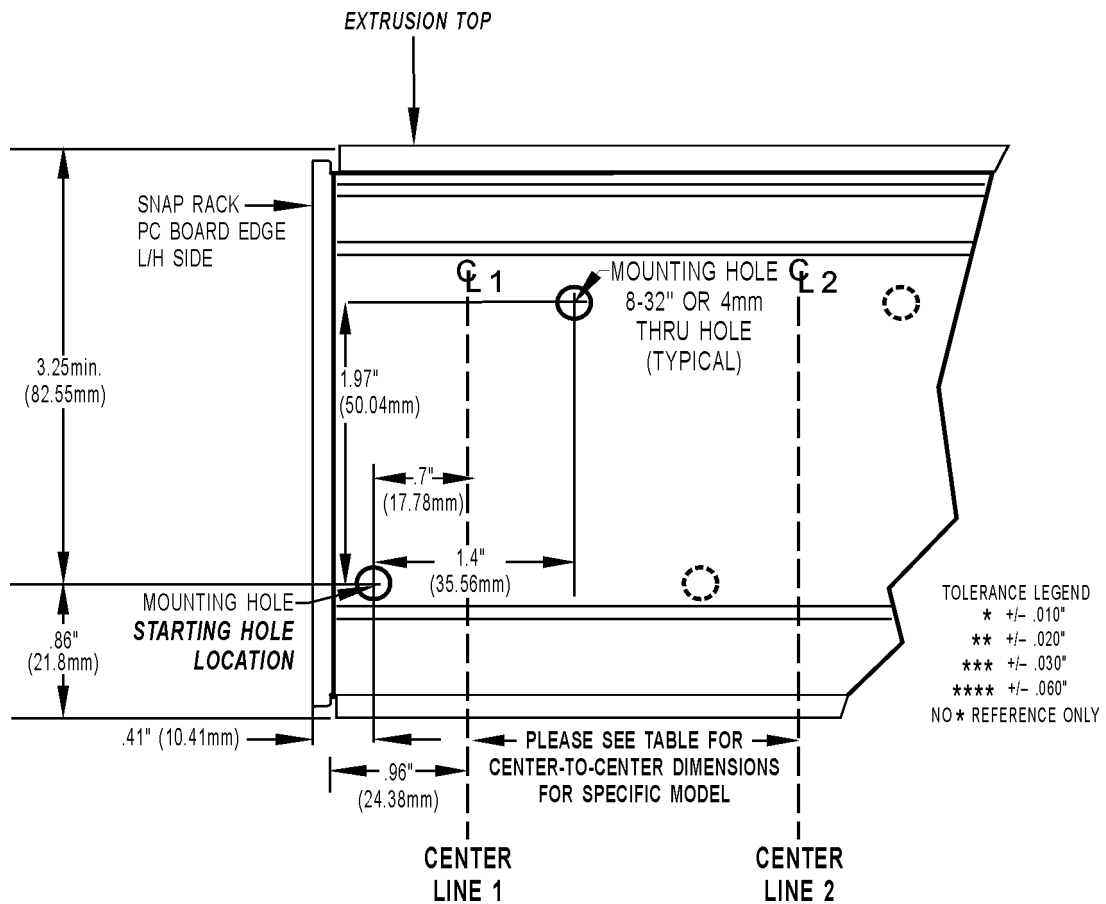

See instructions and table on [page 9](#).

## Wiring Diagrams—B-Series Models with Terminal Strips

### Terminal Strip Usage—Digital

NOTE: Consult the SNAP module data sheet for your specific module for additional wiring information.

#### Example: Digital Input Using Terminal Strip

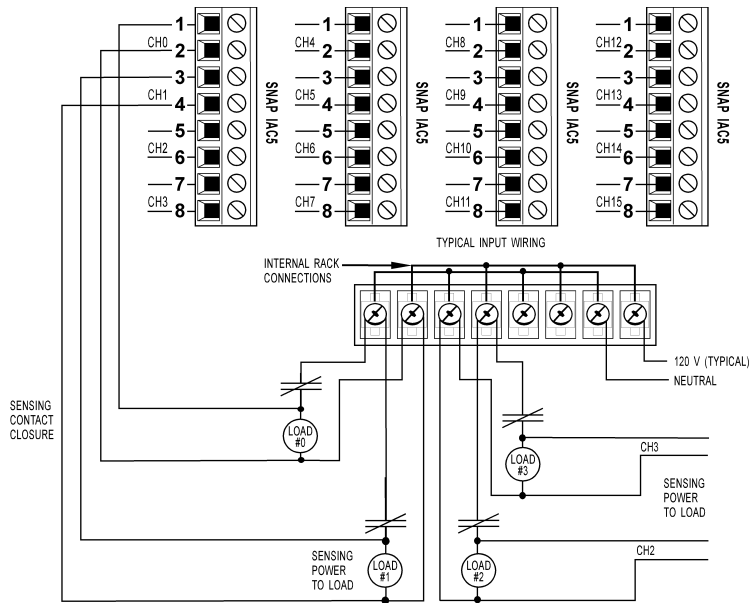

#### Example: Digital AC Output Using Terminal Strip

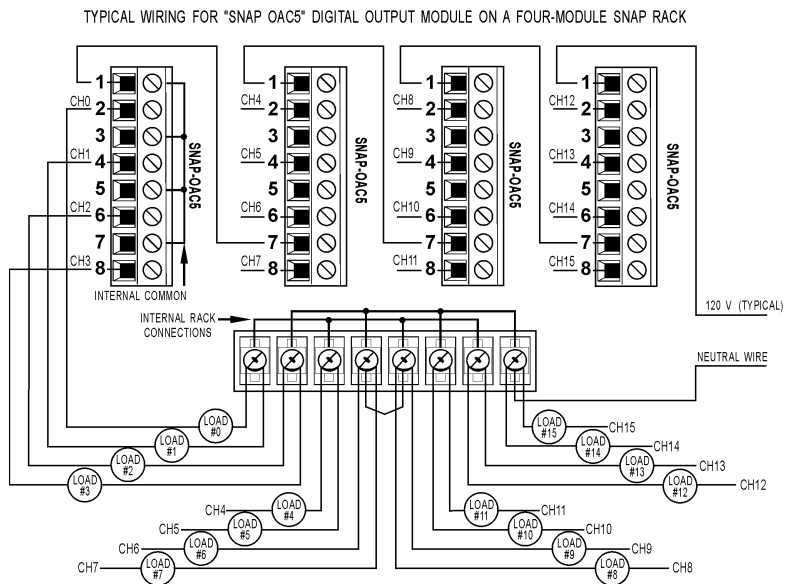

# SNAP I/O Racks

## Wiring Diagrams—B-Series Models with Terminal Strips

### Terminal Strip Usage—Digital (continued)

NOTE: Consult the SNAP module data sheet for your specific module for additional wiring information.

#### Example: Digital DC Output (Sourcing) Using Terminal Strip

TYPICAL WIRING FOR "SNAP ODC5-SRC" DIGITAL OUTPUT MODULE ON A FOUR-MODULE SNAP RACK

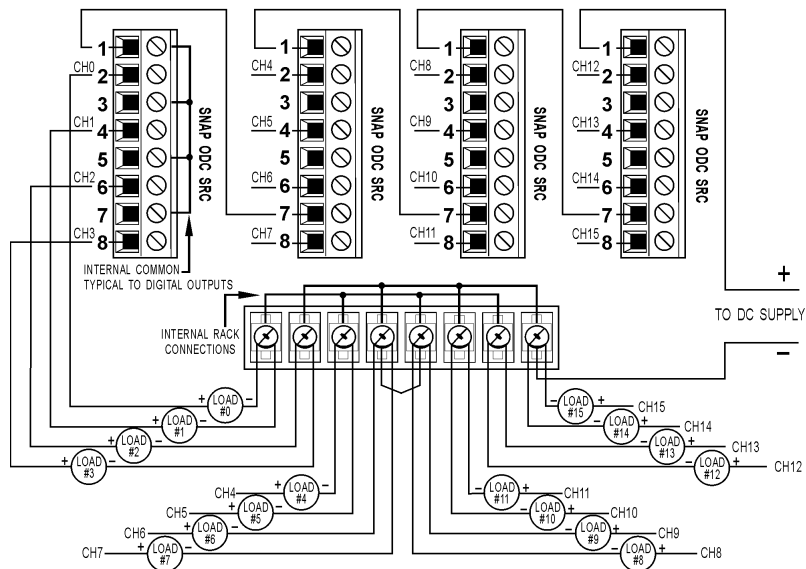

#### Example: Digital DC Output (Sinking) Using Terminal Strip

TYPICAL WIRING FOR "SNAP ODC5-SNK" DIGITAL OUTPUT MODULE ON A FOUR-MODULE SNAP RACK

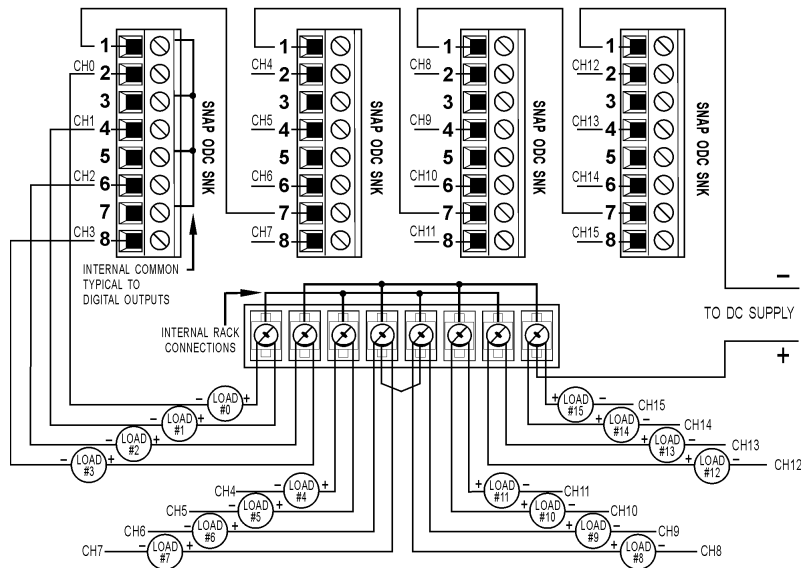

## Wiring Diagrams—B-Series Models with Terminal Strips

### Terminal Strip Usage—Analog

NOTE: Consult the SNAP module data sheet for your specific module for additional wiring information.

#### Example: Analog Input (Current: Negative) Using Terminal Strip

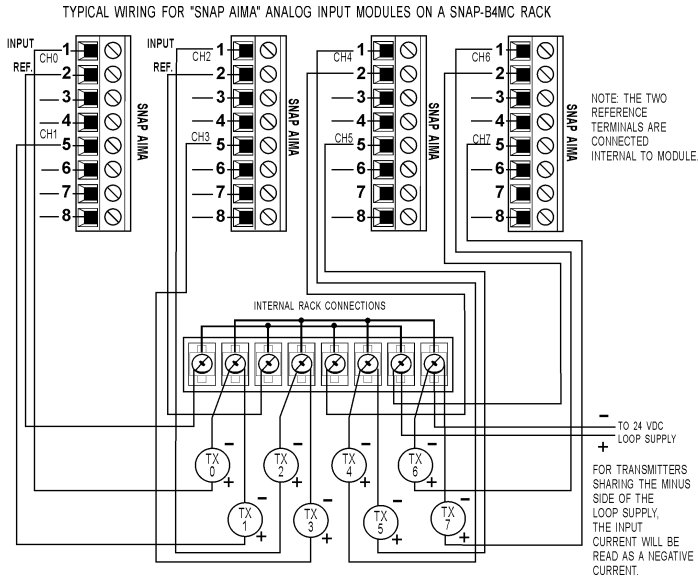

#### Example: Analog Input (Current: Positive) Using Terminal Strip

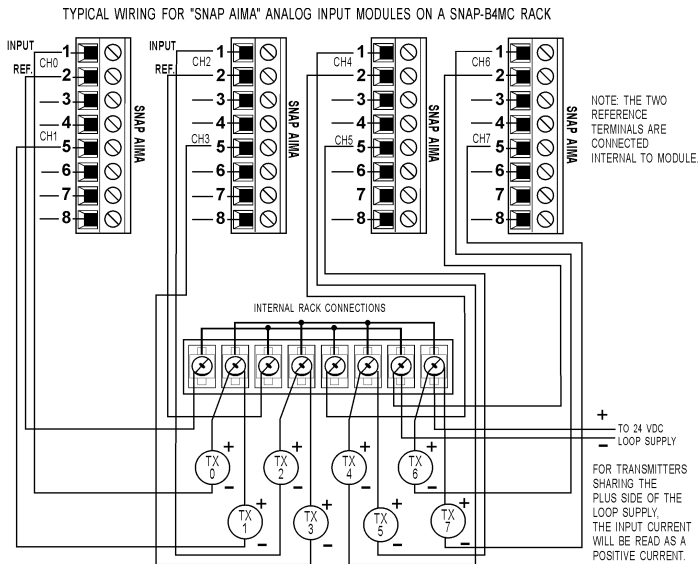

# SNAP I/O Racks

## Wiring Diagrams—B-Series Models with Terminal Strips

### Terminal Strip Usage—Analog (continued)

NOTE: Consult the SNAP module data sheet for your specific module for additional wiring information.

**Example: Analog Output (4–20 mA Current: Sourcing) Using Terminal Strip**

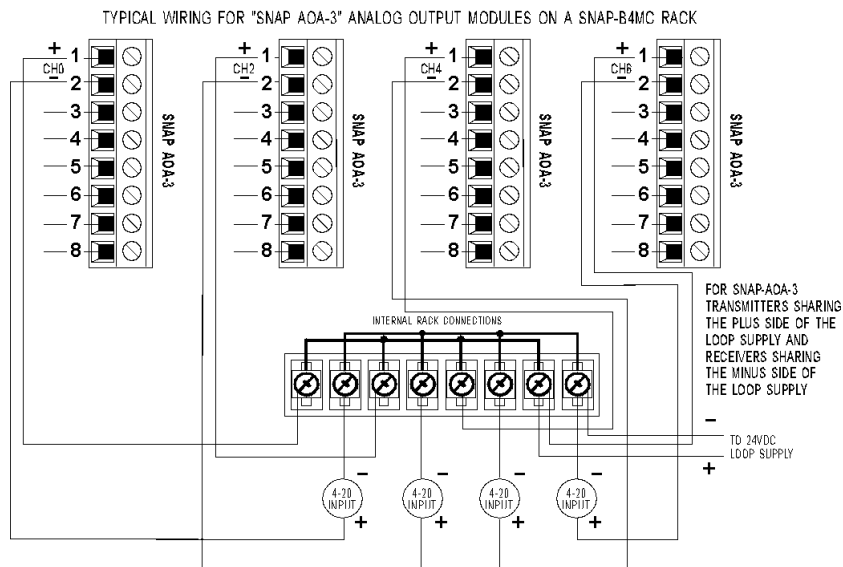

**Example: Analog Output (4–20 mA Current: Sinking) Using Terminal Strip**

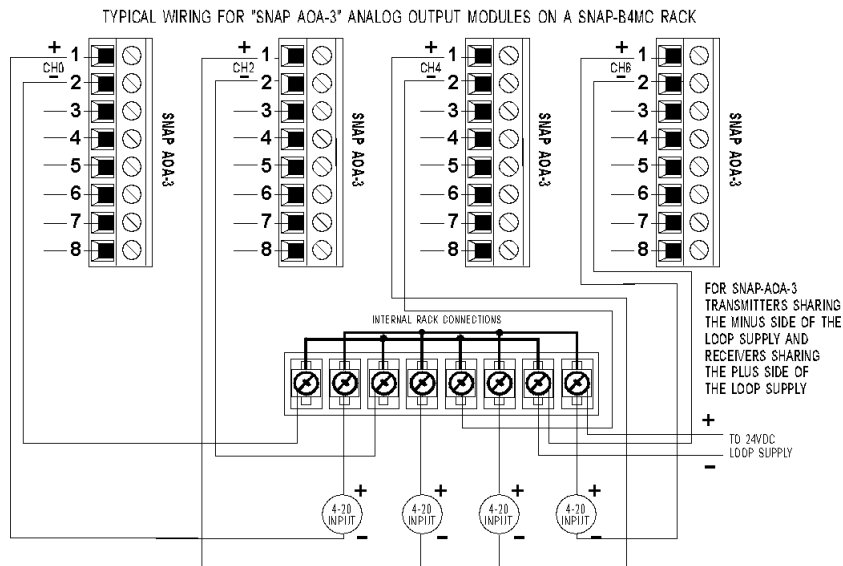

### Wiring Diagrams—B-Series Models with Terminal Strips

#### Terminal Strip Usage—Analog (continued)

NOTE: Consult the SNAP module data sheet for your specific module for additional wiring information.

#### Example: Analog Input (Voltage) Using Terminal Strip

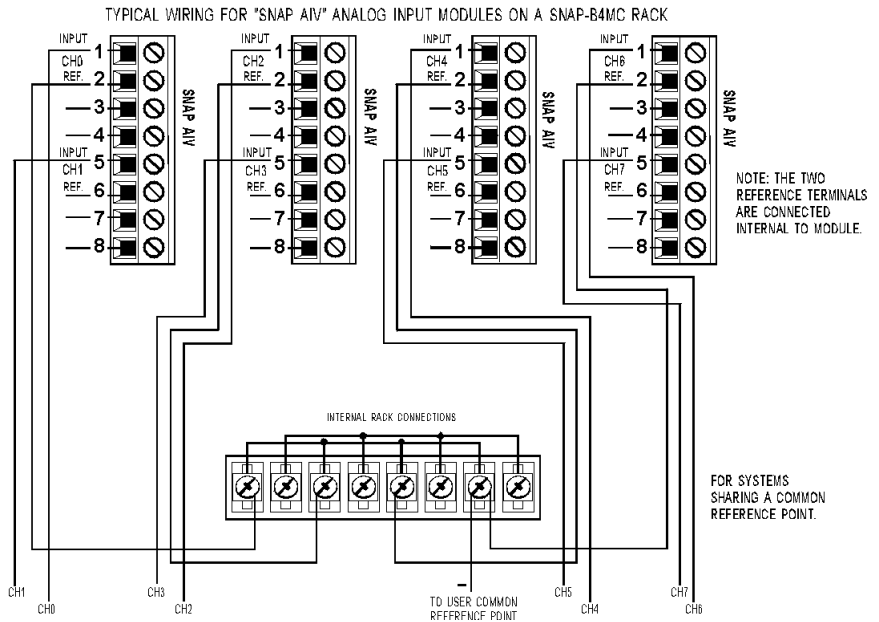

## More About Opto 22

### Products

Opto 22 develops and manufactures a broad array of reliable, flexible hardware and software products for industrial automation, remote monitoring, data acquisition, and machine-to-machine (M2M) applications.

### SNAP PACs (Programmable Automation Controllers)

Programmable automation controllers (PACs) are multifunctional, multidomain, modular controllers based on open standards and providing an integrated development environment. Models include the standalone SNAP PAC S-series and the rack-mounted SNAP PAC R-series. Both handle a wide range of digital, analog, and serial functions and are equally suited to data collection, remote monitoring, process control, and discrete and hybrid manufacturing.

SNAP PACs are based on open Ethernet and Internet Protocol (IP) standards, so you can build or extend a system without the expense and limitations of proprietary networks and protocols.

### ioProject Software Suite

Opto 22's ioProject Software Suite provides full-featured and cost effective control, HMI (human machine interface), and OPC software to power your Opto 22 hardware.

These fully integrated software applications share a single tagname database, so the data points you configure in ioControl™ are immediately available for use in ioDisplay™ and OptoOPCServer™. Commands are in plain English; variables and I/O point names are fully descriptive.

ioProject Basic offers control and HMI tools and is included in your purchase of a SNAP PAC controller. ioProject Professional, available for separate purchase, adds OptoOPCServer, options for Ethernet link redundancy or segmented networking, and support for legacy Opto 22 mistic™ I/O units.

### SNAP Ethernet I/O

Based on worldwide standards Ethernet and Internet Protocol (IP), SNAP Ethernet I/O systems offer flexibility in their network

connectivity and in the software applications they work with, including:

- Opto 22's own ioProject suite of control, HMI, and OPC software
- Modbus®/TCP software and hardware
- Third-party HMIs and other OPC client software
- Database, email, network management, and other enterprise systems
- Custom applications developed with the free OptoMMP Driver Toolkit

SNAP Ethernet I/O also works with SNAP PACs to build a complete automation system: PACs provide central control and data distribution; SNAP Ethernet I/O provides local connection to sensors and equipment and includes distributed intelligence for local control, counting, latching, thermocouple linearization, PID loop control, and more.

### Quality

Founded in 1974 and with over 85 million devices sold, Opto 22 has established a worldwide reputation for high quality products. All are made in the U.S.A. at our manufacturing facility in Temecula, California. Because we do no statistical testing, and each part is tested twice before leaving our factory, we can guarantee most solid-state relays and optically isolated I/O modules for life.

### Free Product Support

Opto 22's Product Support Group offers free, comprehensive technical support for Opto 22 products. Our staff of support engineers represents decades of training and experience. Product support is available in English and Spanish, by phone or email, Monday through Friday, 7 a.m. to 5 p.m. PST.

### Free Customer Training

Hands-on training classes for SNAP PACs, ioProject software, and SNAP Ethernet I/O are offered at our headquarters in Temecula, California. Each student has his or her own learning station; classes are limited to nine students. Registration for the free training class is on a first-come, first-served basis. See [training.opto22.com](http://training.opto22.com) for more information.

### Purchasing Opto 22 Products

Opto 22 products are sold directly and through a worldwide network of distributors, partners, and system integrators. For more information, contact Opto 22 headquarters at 800-321-6786 or visit the website at [www.opto22.com](http://www.opto22.com).

[www.opto22.com](http://www.opto22.com)

