

INCH-POUND

MS27467M
2 February 2012
SUPERSEDING
MS27467L
12 July 2002

DETAIL SPECIFICATION SHEET

CONNECTORS, PLUG, ELECTRICAL, STRAIGHT,
CRIMP TYPE, BAYONET COUPLING, SERIES I

This specification is approved for use by all Departments
and Agencies of the Department of Defense.

The requirements for acquiring the product described herein
shall consist of this specification sheet and MIL-DTL-38999.

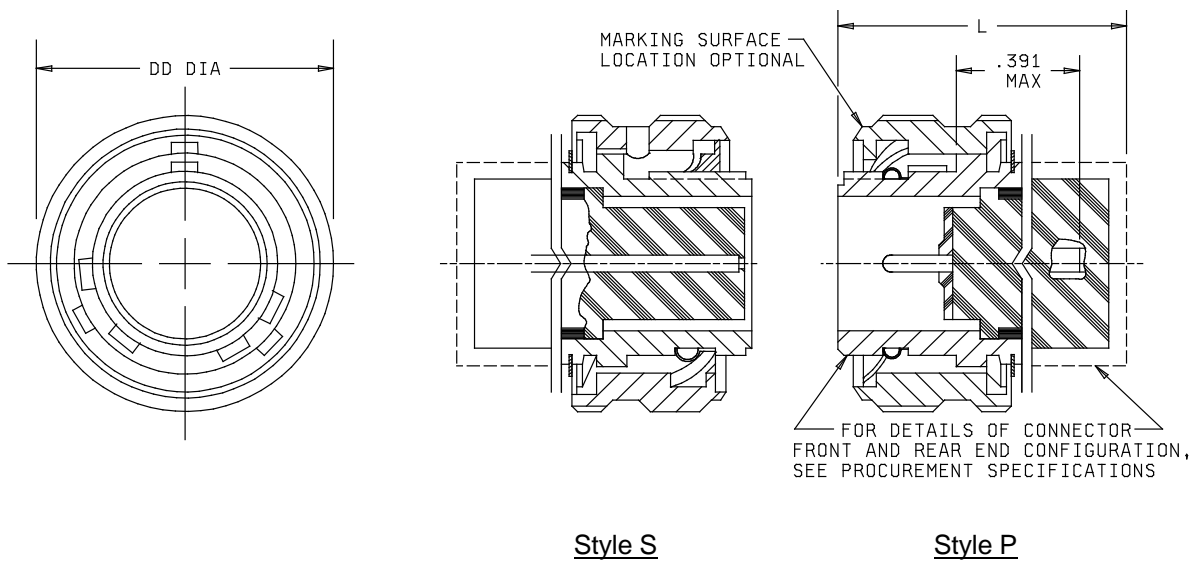

FIGURE 1. Plug, classes E, T and P.

AMSC N/A

FSC 5935

MS27467M

Shell size	L max			DD dia max
	Class E	Class P	Class T (to the end of the serrations)	
9	1.234	1.671	1.234	.859
11				.984
13				1.156
15				1.281
17				1.406
19				1.516
21		1.766		1.641
23				1.766
25	1.891			

Inches	mm	Inches	mm
.391	9.93	1.406	35.71
.859	21.82	1.516	38.51
.984	24.99	1.641	41.68
1.156	29.36	1.671	42.44
1.234	31.34	1.766	43.86
1.281	32.54	1.891	48.03

NOTES:

1. Dimensions are in inches.
2. Metric equivalents are given for information only.
3. For main key positions, see MIL-DTL-38999.
4. Dimensioning and tolerances are in accordance with ASME Y14.5.

FIGURE 1. Plug, classes E, T and P - Continued.

MS27467M

REQUIREMENTS:

Dimensions and configuration: See figure 1.

Interface dimensions shall be in accordance with MIL-DTL-38999.

Mating connectors: MS27466, MS27468, MS27469, MS27470, MS27471, MS27496, MS27505, MS27515, MS27652, MS27654, MS27656 and MS27662.

Insert arrangements: See MIL-STD-1560.

Part or Identifying Number (PIN) example:

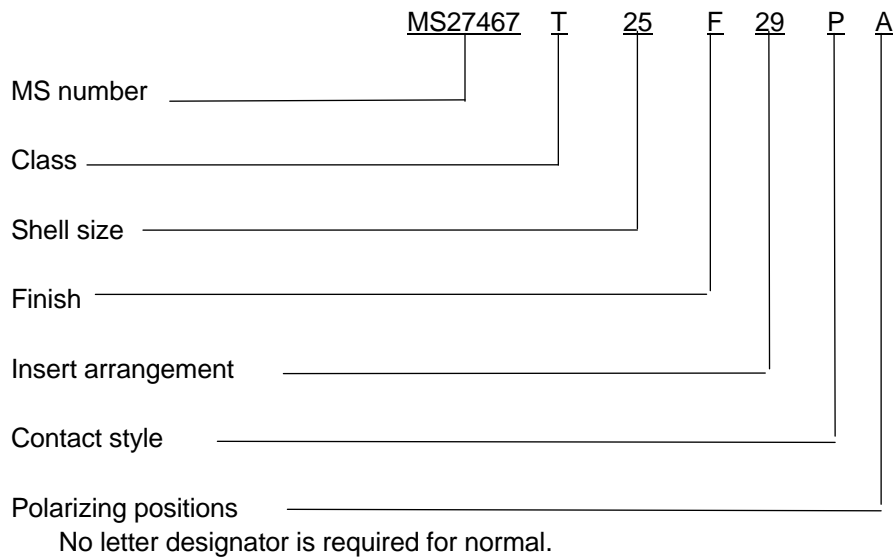

Specification restrictions

Classes E and P are inactive for new design for the Air Force.

MS27467M

Changes from previous issue. Marginal notations are not used in this revision to identify changes with respect to the previous issue, due to the extent of the changes.

Referenced documents. In addition to MIL-DTL-38999, this document references the following:

MIL-STD-1560
MS27466
MS27468
MS27469
MS27470
MS27471
MS27496
MS27505
MS27515
MS27652
MS27654
MS27656
MS27662
ASME Y14.5

CONCLUDING MATERIAL

Custodians:

Army - CR
Navy - AS
Air Force – 85
DLA - CC

Preparing activity:

DLA - CC

(Project 5935–2012-020)

Review activities:

Army - AR, MI
Navy - EC, MC, OS
Air Force - 19, 99
DLA – IS

NOTE: The activities listed above were interested in this document as of the date of this document. Since organizations and responsibilities can change, you should verify the currency of the information above using the ASSIST Online database at <https://assist.daps.dla.mil>.