

| | |
|------------------------|------------------------------------|
| DRAWING NUMBER: | 01-1104-1-03XX |
| PRODUCT GROUP: | BINDING POSTS |
| SUB-GROUP: | MILITARY BINDING POSTS |
| DESCRIPTION: | MINIATURE FLUTED HEAD BINDING POST |

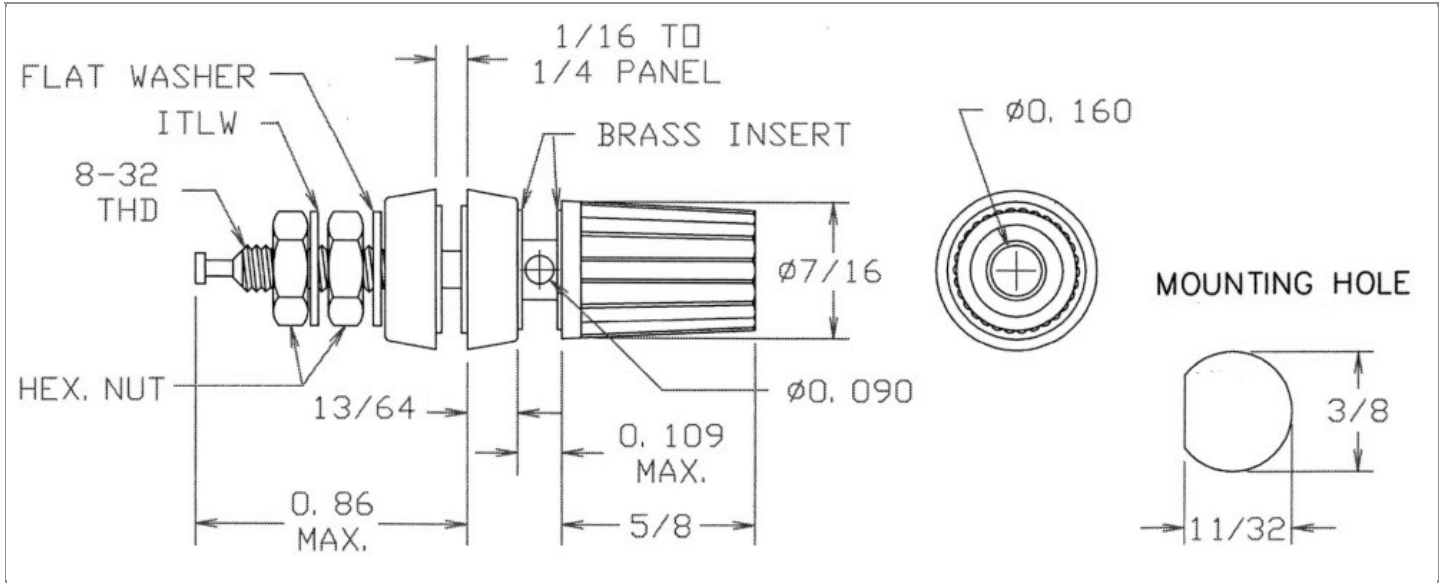

| OVERALL LENGTH | BOARD / PANEL MOUNTING METHOD | MOUNTING HOLE SIZE | DRILL SIZE | BOARD / PANEL THICKNESS |
|----------------|-------------------------------|------------------------|------------|-------------------------|
| 1.657" MAX. | THREAD MOUNT (8-32 NUT) | 3/8" x 11/32" "D" HOLE | 3/8" | 1/16" - 1/4" |

PART NO. STRUCTURE:

| | | | | | |
|-------------|---|-----------|---|--------|------------------|
| 01-1104 | - | 1 | - | XX | XX |
| PART SERIES | | DIMENSION | | FINISH | INSULATION COLOR |

MATERIAL OPTIONS:

01-1104-1-XXXX

| COMPONENT | MATERIAL | MATERIAL AND SPECIFICATION |
|---------------|-----------------|--|
| BODY | BRASS | BRASS PER ASTM B16, ALLOY C36000, 1/2 HARD |
| HEAD | POLYCARBONATE | POLYCARBONATE PER ASTM D3935 |
| INSULATION* | POLYCARBONATE | POLYCARBONATE PER ASTM D3935 |
| SPRING (CAGE) | N/A | N/A |
| NUT | BRASS | BRASS PER ASTM B16, ALLOY C36000, 1/2 HARD |
| WASHER | PHOSPHOR BRONZE | PHOSPHOR BRONZE PER ASTM B103/B139, ALLOY C51000 |

*For Insulation color, please see INSULATION COLOR OPTIONS on Page 2

FINISH - PLATING OPTIONS:

01-1104-1-XXXX

| FINISH CODE | COMPONENT | FINISH | FINISH AND SPECIFICATION |
|-------------|---------------|--------|--|
| 03 | BODY | GOLD | GOLD FLASH PER ASTM B488, TYPE II, CODE C OVER NICKEL PER SAE-AMS-QQ-N-290 |
| | HEAD | N/A | N/A |
| | SPRING (CAGE) | N/A | N/A |
| | NUT | GOLD | GOLD FLASH PER ASTM B488, TYPE II, CODE C OVER NICKEL PER SAE-AMS-QQ-N-290 |
| | WASHER | GOLD | GOLD FLASH PER ASTM B488, TYPE II, CODE C OVER NICKEL PER SAE-AMS-QQ-N-290 |

INSULATION COLOR OPTIONS:

01-1104-1-XXXX

| INSULATION COLOR | BLACK | RED |
|------------------|-------|-----|
| COLOR CODE NO. | 10 | 12 |

TOLERANCES:*

| DECIMAL | FRACTIONAL | ANGULAR | DRAWING ORIGINATION DATE | LAST MODIFICATION DATE |
|---------------------------|------------|---------|--------------------------|------------------------|
| .XXX ± 0.005 / .XX ± 0.01 | ± 1/64 | N/A | 6/23/1998 | 5/1/2017 |

*All dimensions are in inches.

RoHS COMPLIANCE:

01-1104-1-03XX

| PART NUMBER | RoHS COMPLIANT |
|----------------|----------------|
| 01-1104-1-0310 | YES |
| 01-1104-1-0312 | YES |

MILITARY REFERENCE SPECIFICATIONS:

01-1104-1-03XX

| PART NUMBER | MIL SPECIFICATION | MIL PART NUMBER | COMMERCIAL ITEM DESCRIPTION (CID) SPECIFICATION | CID PART NUMBER |
|----------------|-------------------|---------------------------------|---|-----------------|
| 01-1104-1-0310 | MIL-P-55149/01 | MIL-P-55149/01-FA-02 (PB01FA02) | A-A-59560 | AA59560-2 |
| 01-1104-1-0312 | MIL-P-55149/01 | MIL-P-55149/01-FA-01 (PB01FA01) | A-A-59560 | AA59560-1 |

NOTES:

DATASHEET NOTES

RATED: 15 AMPERES CURRENT CAPACITY, 1000 VDC WORKING LIMIT. POST IS COMPLETELY INSULATED FROM CHASSIS. FOR PANELS FROM 1/16" TO 1/4" THICK. FIVE WAY BINDING POST: ACCEPTS STANDARD BANANA PLUG, CLIP LEAD TO SHAFT, LOOP WIRE AROUND SHAFT AND CLAMP WITH HEAD, INSERT WIRE THRU CROSS HOLE AND CLAMP WITH HEAD, SPADE LUG CLAMPED WITH HEAD. SUPPLIED WITH HARDWARE.

INSTRUCTION NOTES

SUPPLIED WITH: TWO GOLD PLATED BRASS HEX NUTS P/N 701-7323-03 (8-32 x 11/32" x 1/8"), ONE GOLD PLATED PHOSPHOR BRONZE #8 INTERNAL TOOTH LOCKWASHER P/N 701-7778-03, ONE GOLD PLATED BRASS #8 FLAT WASHER P/N 701-7761-03, MOLDED POLYCARBONATE WASHER. INSERT - GOLD PLATED BRASS.