

THIS DRAWING IS UNPUBLISHED. RELEASED FOR PUBLICATION 20
 © COPYRIGHT 20 BY - ALL RIGHTS RESERVED.

REVISIONS				
P	LTR	DESCRIPTION	DATE	APVD
A8		ECR-19-008771	6JUN2019	LZ FL
A9		ECR-19-014915	26SEP2019	LZ FL
A10		ECR-19-016785	29OCT2019	LZ FL

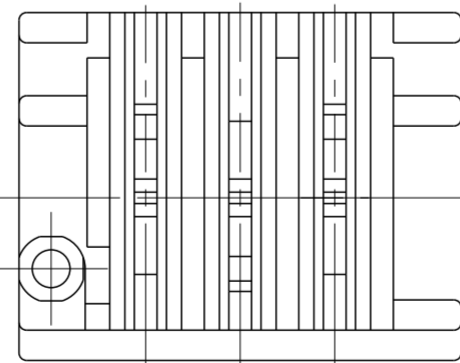

- SEE SHEET 2 FOR AVAILABLE CONFIGURATIONS
- MATERIAL: HOUSING, NYLON, UL94 V0, 750°C GWT NO FLAME CONTACT, COPPER ALLOY, 0.60MM THICK
- FINISH: TIN PLATING OVER NICKEL UNDERPLATING
- PCB LAYOUT AS SHOWN
- PRELIMINARY, NOT FOR PRODUCTION

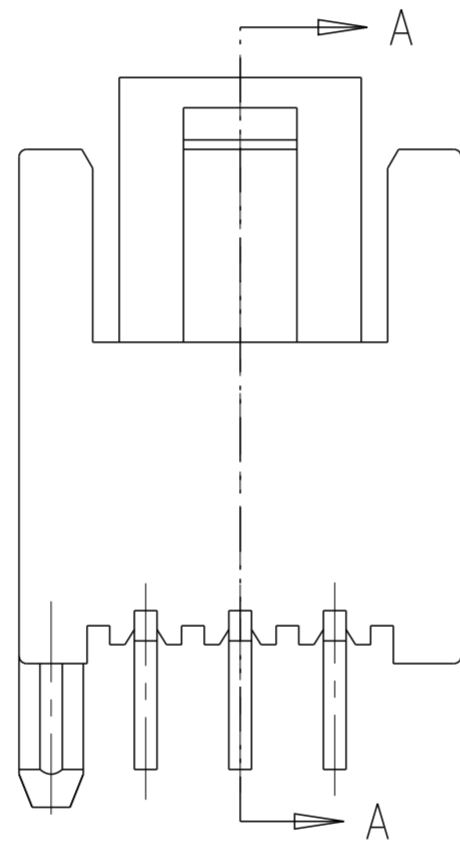
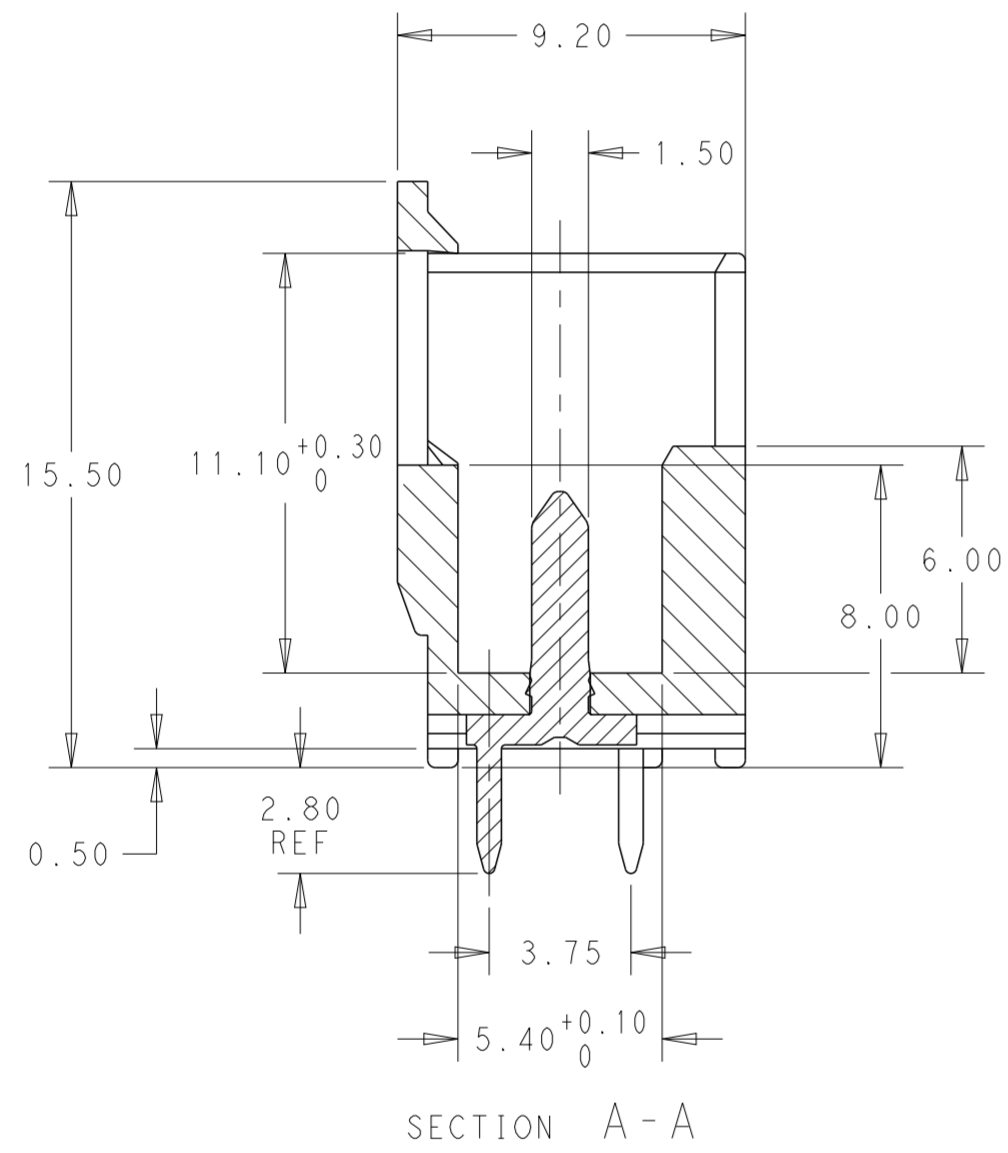
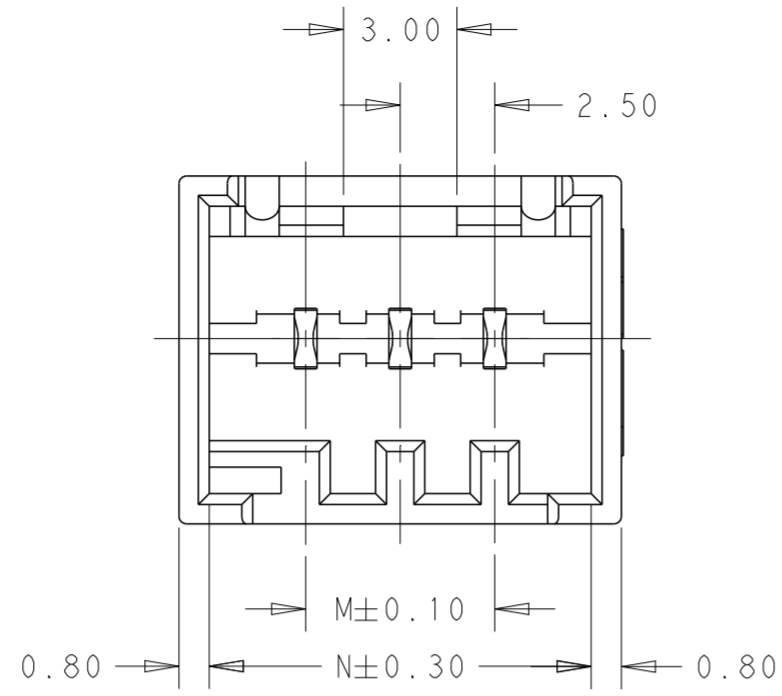
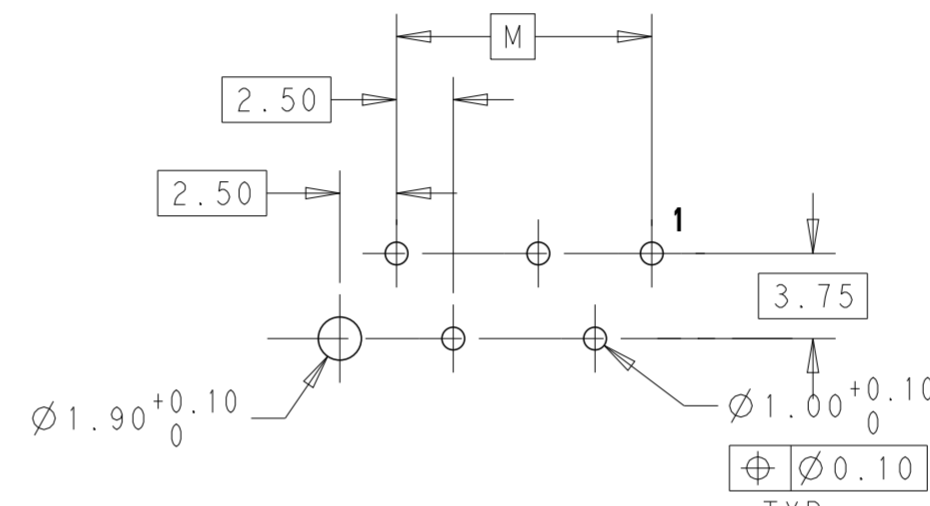

PCB LAYOUT A - SOLDER SIDE
ODD NUMBER OF PINS

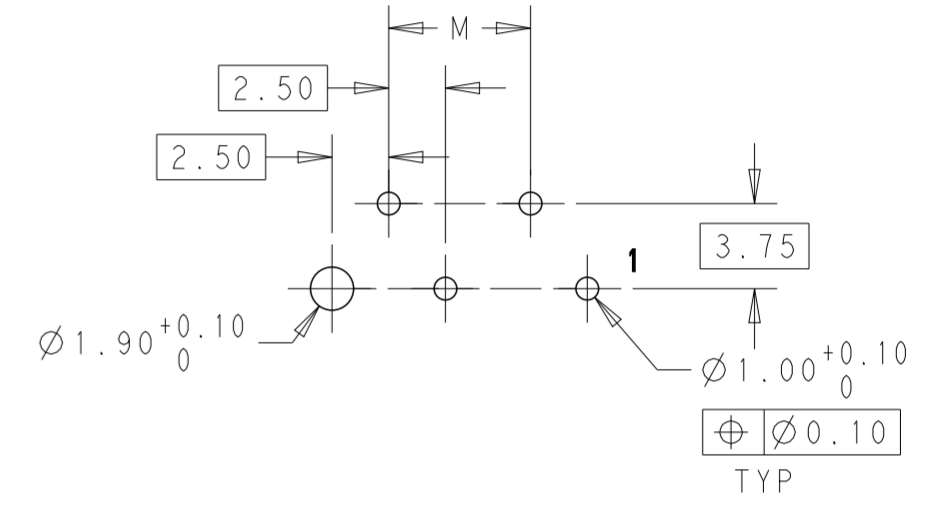

PCB LAYOUT A - SOLDER SIDE
EVEN NUMBER OF PINS

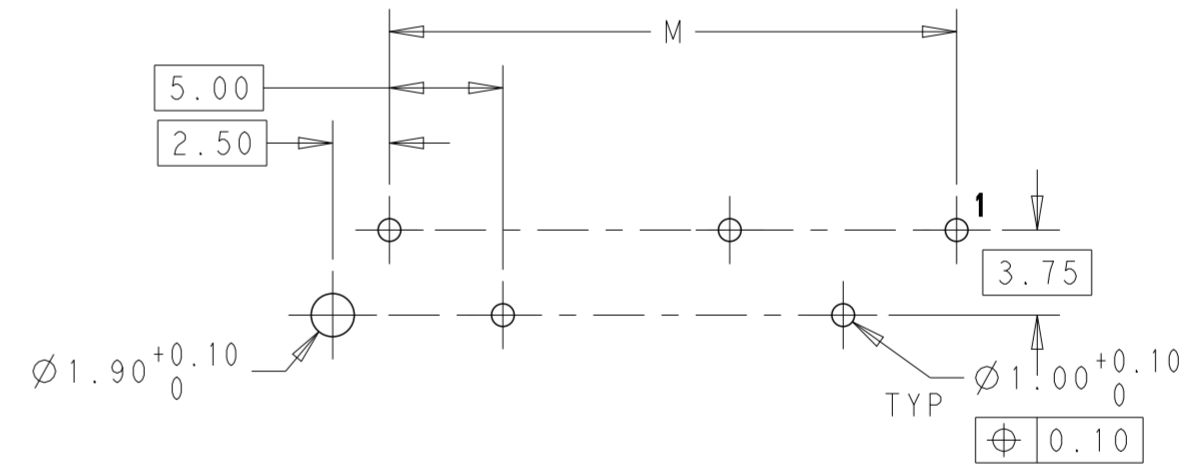

PCB LAYOUT B - SOLDER SIDE
ODD NUMBER OF PINS

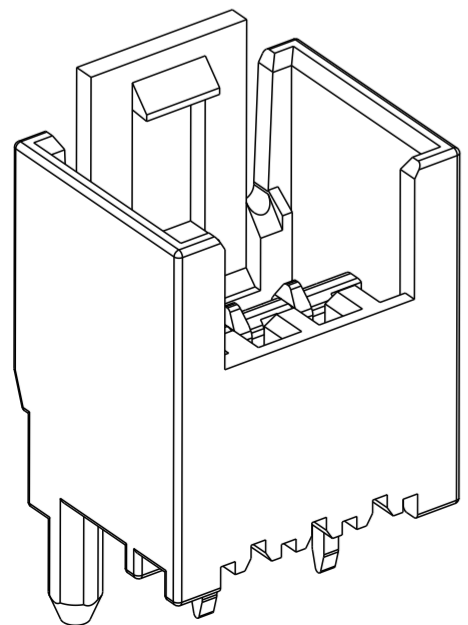

40.00	40.00	45.10	40.00	17
20.00	20.00	25.10	20.00	9
15.00	-	20.10	15.00	7
10.00	-	17.60	12.50	6
10.00	10.00	15.10	10.00	5
5.00	-	12.60	7.50	4
5.00	5.00	10.10	5.00	3
Q	P	N	M	POS

THIS DRAWING IS A CONTROLLED DOCUMENT.		DWN 16APR2015 WINTER WANG	TE Connectivity	
		CHK 16APR2015 JAIN LIU		
DIMENSIONS: mm		APVD 16APR2015 RICCARDO ROBONE	NAME RAST 2.5 TAB HEADER ASSY POTTED VERSION	
TOLERANCES UNLESS OTHERWISE SPECIFIED:		PRODUCT SPEC 108-106079	SIZE CAGE CODE DRAWING NO RESTRICTED TO	
0 PLC ±		APPLICATION SPEC	A200779 C-2232960	
1 PLC ±		WEIGHT	SCALE 5:1 SHEET 1 OF 5 REV A10	
2 PLC ±0.20		CUSTOMER DRAWING		
3 PLC ±				
4 PLC ±				
ANGLES ±1°				
FINISH				

THIS DRAWING IS UNPUBLISHED. RELEASED FOR PUBLICATION 20
 © COPYRIGHT 20 BY - ALL RIGHTS RESERVED.

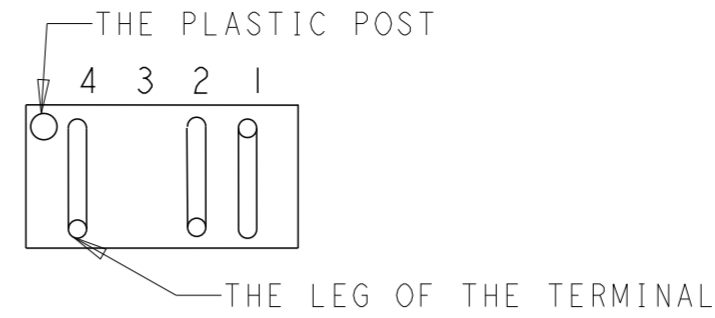
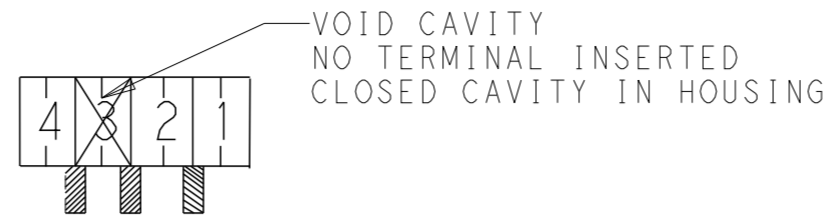

REVISIONS					
P	LTR	DESCRIPTION	DATE	DWN	APVD
-	-	SEE SHEET 1	-	-	-

KEYING CONFIGURATION	TAIL CONFIGURATION	PCB LAYOUT	COLOR	VOID CAVITY	CAVITY	TE PART NUMBER
		A	NATURAL	-	4	4-2232960-4
		A	NATURAL	-	4	3-2232960-4
		A	BLACK	-	4	2-2232960-4
		A	NATURAL	3	4	1-2232960-4
		B	BLACK	2	3	2-2232962-3
		B	NATURAL	2	3	1-2232962-3
		A	NATURAL	-	3	5-2232960-3
		A	NATURAL	-	3	4-2232960-3
		A	BLACK	-	3	3-2232960-3
		A	BLACK	-	3	2-2232960-3
		A	NATURAL	-	3	1-2232960-3

THIS DRAWING IS A CONTROLLED DOCUMENT.		DWN 16APR2015 WINTER WANG	TE Connectivity
DIMENSIONS: mm		CHK 16APR2015 JAIN LIU	
TOLERANCES UNLESS OTHERWISE SPECIFIED:		APVD 16APR2015 RICCARDO ROBONE	
0 PLC ± 1 PLC ± 2 PLC ±0.20 3 PLC ± 4 PLC ± ANGLES ±1° FINISH -		PRODUCT SPEC 108-106079 APPLICATION SPEC - WEIGHT -	NAME RAST 2.5 TAB HEADER ASSY POTTED VERSION SIZE CAGE CODE DRAWING NO RESTRICTED TO A200779 C-2232960 -
MATERIAL -		CUSTOMER DRAWING	SCALE 5:1 SHEET 2 OF 5 REV A10

THIS DRAWING IS UNPUBLISHED. RELEASED FOR PUBLICATION 20
 © COPYRIGHT 20 BY - ALL RIGHTS RESERVED.

REVISIONS					
P	LTR	DESCRIPTION	DATE	DWN	APVD
-		SEE SHEET 1	-	-	-

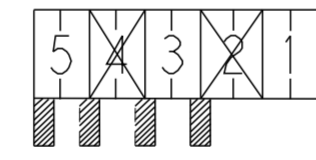
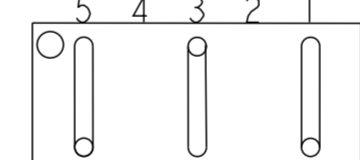
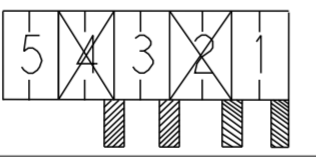
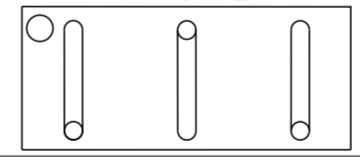
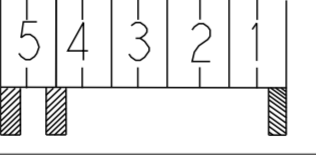
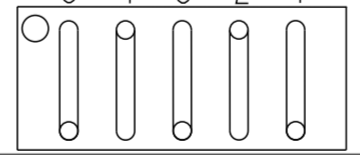
		B	NATURAL	2, 4	5	3-2232962-5
		B	BLACK	2, 4	5	1-2232962-5
		A	NATURAL	-	5	1-2232960-5
KEYING CONFIGURATION	TAIL CONFIGURATION	PCB LAYOUT	COLOR	VOID CAVITY	CAVITY	TE PART NUMBER

THIS DRAWING IS A CONTROLLED DOCUMENT.		DWN WINTER WANG 16APR2015	 TE Connectivity	
		CHK JAIN LIU 16APR2015		
DIMENSIONS: mm		APVD RICCARDO ROBONE 16APR2015	NAME RAST 2.5 TAB HEADER ASSY POTTED VERSION	
TOLERANCES UNLESS OTHERWISE SPECIFIED: 0 PLC ± 1 PLC ± 2 PLC ±0.20 3 PLC ± 4 PLC ± ANGLES ±1° FINISH		PRODUCT SPEC 108-106079	APPLICATION SPEC -	RESTRICTED TO -
MATERIAL -		WEIGHT -	SIZE A200779	CAGE CODE C-2232960
		CUSTOMER DRAWING	SCALE 5:1	SHEET 3 OF 5
				REV A10

THIS DRAWING IS UNPUBLISHED. RELEASED FOR PUBLICATION 20
 © COPYRIGHT 20 BY - ALL RIGHTS RESERVED.

REVISIONS				
P	LTR	DESCRIPTION	DATE	APVD
-	-	SEE SHEET 1	-	-

		B	NATURAL	2, 4, 6, 8, 10, 12, 14, 16	17	2-2232963-7
		B	NATURAL	2, 4, 6, 8, 10, 12, 14, 16	17	1-2232963-7
		B	NATURAL	2, 4, 6, 8	9	1-2232962-9
		A	NATURAL	-	9	2-2232960-9
		A	NATURAL	-	9	1-2232960-9
		B	NATURAL	2, 4, 6	7	1-2232962-7
		A	NATURAL	-	7	2-2232960-7
		A	NATURAL	-	7	1-2232960-7
		A	NATURAL	-	6	1-2232960-6
KEYING CONFIGURATION	TAIL CONFIGURATION	PCB LAYOUT	COLOR	VOID CAVITY	CAVITY	TE PART NUMBER

THIS DRAWING IS A CONTROLLED DOCUMENT.

DWN	16APR2015	WINTER WANG
CHK	16APR2015	JAIN LIU
APVD	16APR2015	RICCARDO ROBONE
PRODUCT SPEC	108-106079	
APPLICATION SPEC	-	
WEIGHT	-	
CUSTOMER DRAWING	SCALE	5:1

STE TE Connectivity

NAME: RAST 2.5 TAB HEADER ASSY POTTED VERSION

SIZE	CAGE CODE	DRAWING NO	RESTRICTED TO
A2	00779	C-2232960	-

SCALE 5:1 SHEET 4 OF 5 REV A10

THIS DRAWING IS UNPUBLISHED. RELEASED FOR PUBLICATION 20
 © COPYRIGHT 20 BY - ALL RIGHTS RESERVED.

REVISIONS					
P	LTR	DESCRIPTION	DATE	DWN	APVD
-	-	SEE SHEET 1	-	-	-

PARTS WITH SPECIAL PCB LAYOUT

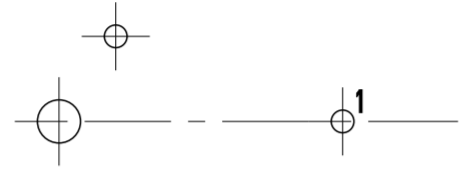

PCB LAYOUT C - SOLDER SIDE

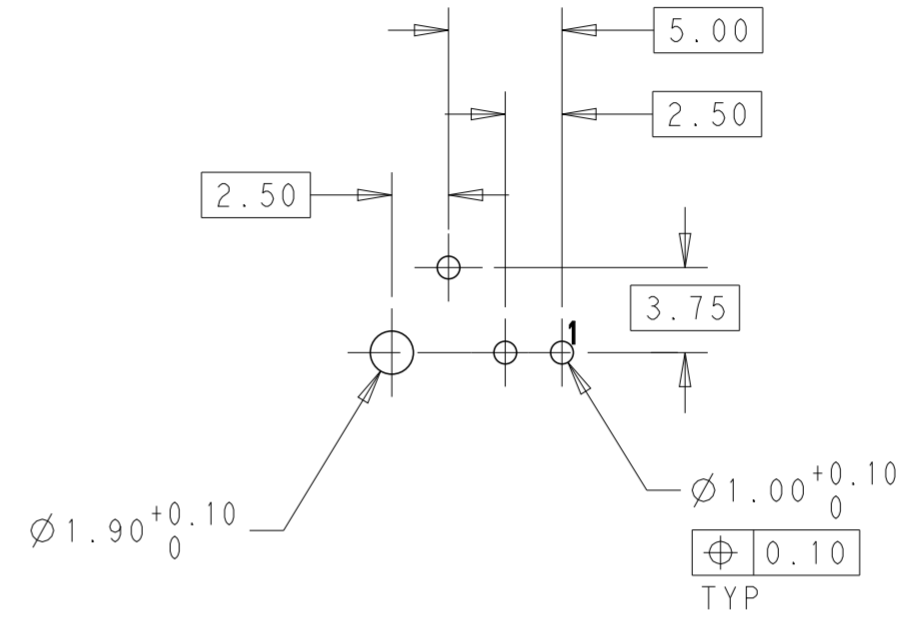

PCB LAYOUT D - SOLDER SIDE

		C	NATURAL	2, 3, 4	5	2-2232962-5
		D	NATURAL	-	3	2364721-3
KEYING CONFIGURATION	TAIL CONFIGURATION	PCB LAYOUT	COLOR	VOID CAVITY	CAVITY	TE PART NUMBER

THIS DRAWING IS A CONTROLLED DOCUMENT.		DWN 16APR2015 WINTER WANG	TE Connectivity			
		CHK 16APR2015 JAIN LIU				
DIMENSIONS: mm		APVD 16APR2015 RICCARDO ROBONE	NAME RAST 2.5 TAB HEADER ASSY POTTED VERSION			
TOLERANCES UNLESS OTHERWISE SPECIFIED: 0 PLC ± 1 PLC ± 2 PLC ±0.20 3 PLC ± 4 PLC ± ANGLES ±1° FINISH		PRODUCT SPEC 108-106079	APPLICATION SPEC -	SIZE A200779	CAGE CODE C-2232960	DRAWING NO -
MATERIAL -		WEIGHT -	RESTRICTED TO -		SCALE 5:1 SHEET 5 OF 5 REV A10	
CUSTOMER DRAWING						